**Information technology — Generic coding
of moving pictures and associated audio
information —**

**Part 7:
Advanced Audio Coding (AAC)**

*Technologies de l'information — Codage générique des images
animées et du son associé —*

Partie 7: Codage du son avancé (AAC)

PDF disclaimer

This PDF file may contain embedded typefaces. In accordance with Adobe's licensing policy, this file may be printed or viewed but shall not be edited unless the typefaces which are embedded are licensed to and installed on the computer performing the editing. In downloading this file, parties accept therein the responsibility of not infringing Adobe's licensing policy. The ISO Central Secretariat accepts no liability in this area.

Adobe is a trademark of Adobe Systems Incorporated.

Details of the software products used to create this PDF file can be found in the General Info relative to the file; the PDF-creation parameters were optimized for printing. Every care has been taken to ensure that the file is suitable for use by ISO member bodies. In the unlikely event that a problem relating to it is found, please inform the Central Secretariat at the address given below.

© ISO/IEC 2006

All rights reserved. Unless otherwise specified, no part of this publication may be reproduced or utilized in any form or by any means, electronic or mechanical, including photocopying and microfilm, without permission in writing from either ISO at the address below or ISO's member body in the country of the requester.

ISO copyright office
Case postale 56 • CH-1211 Geneva 20
Tel. + 41 22 749 01 11
Fax + 41 22 749 09 47
E-mail copyright@iso.org
Web www.iso.org

Published in Switzerland

Contents

Page

Foreword.....	v
Introduction	vi
1 Scope	1
1.1 General.....	1
1.2 MPEG-2 AAC Tools Overview.....	1
2 Normative References	7
3 Terms and Definitions	7
4 Symbols and Abbreviations	14
4.1 Arithmetic Operators	14
4.2 Logical Operators	15
4.3 Relational Operators	15
4.4 Bitwise Operators	16
4.5 Assignment	16
4.6 Mnemonics	16
4.7 Constants	16
5 Method of Describing Bitstream Syntax	16
6 Syntax	18
6.1 Audio Data Interchange Format, ADIF.....	18
6.2 Audio Data Transport Stream, ADTS	19
6.3 Raw Data.....	21
7 Profiles and Profile Interoperability	33
7.1 Profiles	33
7.2 Profile Interoperability.....	35
8 Overall Data Structure	36
8.1 AAC Interchange Formats	36
8.2 Raw Data.....	41
8.3 Single Channel Element (SCE), Channel Pair Element (CPE) and Individual Channel Stream (ICS)	45
8.4 Low Frequency Enhancement Channel (LFE)	51
8.5 Program Config Element (PCE).....	51
8.6 Data Stream Element (DSE)	56
8.7 Fill Element (FIL)	56
8.8 Extension Payload	57
8.9 Tables.....	61
8.10 Figures	70
9 Noiseless Coding.....	70
9.1 Tool Description.....	70
9.2 Definitions	71
9.3 Decoding Process.....	73
9.4 Tables.....	76
10 Quantization	76
10.1 Tool Description.....	76
10.2 Definitions	76
10.3 Decoding Process.....	76
11 Scalefactors.....	77
11.1 Tool Description.....	77

11.2	Definitions.....	77
11.3	Decoding Process.....	78
12	Joint Coding	79
12.1	M/S Stereo.....	79
12.2	Intensity Stereo	80
12.3	Coupling Channel	82
13	Prediction.....	86
13.1	Tool Description.....	86
13.2	Definitions.....	86
13.3	Decoding Process.....	87
13.4	Diagrams	93
14	Temporal Noise Shaping (TNS)	93
14.1	Tool Description.....	93
14.2	Definitions.....	94
14.3	Decoding Process.....	94
15	Filterbank and Block Switching.....	96
15.1	Tool Description.....	96
15.2	Definitions.....	96
15.3	Decoding Process.....	97
16	Gain Control.....	101
16.1	Tool Description.....	101
16.2	Definitions.....	102
16.3	Decoding Process.....	102
16.4	Diagrams	109
16.5	Tables	109
Annex A (normative) Huffman Codebook Tables.....		111
Annex B (informative) Information on Unused Codebooks		130
Annex C (informative) Encoder		131
Annex D (informative) Patent Holders		189
Annex E (informative) Registration Procedure		190
Annex F (informative) Registration Application Form		192
Annex G (informative) Registration Authority		193
Bibliography		194

Foreword

ISO (the International Organization for Standardization) and IEC (the International Electrotechnical Commission) form the specialized system for worldwide standardization. National bodies that are members of ISO or IEC participate in the development of International Standards through technical committees established by the respective organization to deal with particular fields of technical activity. ISO and IEC technical committees collaborate in fields of mutual interest. Other international organizations, governmental and non-governmental, in liaison with ISO and IEC, also take part in the work. In the field of information technology, ISO and IEC have established a joint technical committee, ISO/IEC JTC 1.

International Standards are drafted in accordance with the rules given in the ISO/IEC Directives, Part 2.

The main task of the joint technical committee is to prepare International Standards. Draft International Standards adopted by the joint technical committee are circulated to national bodies for voting. Publication as an International Standard requires approval by at least 75 % of the national bodies casting a vote.

Attention is drawn to the possibility that some of the elements of this document may be the subject of patent rights. ISO and IEC shall not be held responsible for identifying any or all such patent rights.

ISO/IEC 13818-7 was prepared by Joint Technical Committee ISO/IEC JTC 1, *Information technology*, Subcommittee SC 29, *Coding of audio, picture, multimedia and hypermedia information*.

This fourth edition cancels and replaces the third edition (ISO 13818-7:2004), which has been technically revised. It also incorporates the Technical Corrigendum ISO/IEC 13818-7:2004/Cor.1:2005.

ISO/IEC 13818 consists of the following parts, under the general title *Information technology — Generic coding of moving pictures and associated audio information*:

- *Part 1: Systems*
- *Part 2: Video*
- *Part 3: Audio*
- *Part 4: Conformance testing*
- *Part 5: Software simulation* [Technical Report]
- *Part 6: Extensions for DSM-CC*
- *Part 7: Advanced Audio Coding (AAC)*
- *Part 9: Extension for real time interface for systems decoders*
- *Part 10: Conformance extensions for Digital Storage Media Command and Control (DSM-CC)*
- *Part 11: IPMP on MPEG-2 systems*

Introduction

The standardization body ISO/IEC JTC 1/SC 29/WG 11, also known as the Moving Pictures Experts Group (MPEG), was established in 1988 to specify digital video and audio coding schemes at low data rates. MPEG completed its first phase of audio specifications (MPEG-1) in November 1992, ISO/IEC 11172-3. In its second phase of development, the MPEG Audio subgroup defined a multichannel extension to MPEG-1 audio that is backwards compatible with existing MPEG-1 systems (MPEG-2 BC) and defined an audio coding standard at lower sampling frequencies than MPEG-1, ISO/IEC 13818-3.

The International Organization for Standardization (ISO) and International Electrotechnical Commission (IEC) draw attention to the fact that it is claimed that compliance with this document may involve the use of patents.

The ISO and IEC take no position concerning the evidence, validity and scope of this patent right.

The holder of this patent right has assured the ISO and IEC that he is willing to negotiate licences under reasonable and non-discriminatory terms and conditions with applicants throughout the world. In this respect, the statement of the holder of this patent right is registered with the ISO and IEC. Information may be obtained from the companies listed in Annex D.

Attention is drawn to the possibility that some of the elements of this document may be the subject of patent rights other than those identified in Annex D. ISO and IEC shall not be held responsible for identifying any or all such patent rights.

Information technology — Generic coding of moving pictures and associated audio information —

Part 7: Advanced Audio Coding (AAC)

1 Scope

1.1 General

This International Standard describes the MPEG-2 audio non-backwards compatible standard called MPEG-2 Advanced Audio Coding, AAC [1], a higher quality multichannel standard than achievable while requiring MPEG-1 backwards compatibility. This MPEG-2 AAC audio standard allows for ITU-R “indistinguishable” quality according to [2] at data rates of 320 kbit/s for five full-bandwidth channel audio signals.

The AAC decoding process makes use of a number of required tools and a number of optional tools. Table 1 lists the tools and their status as required or optional. Required tools are mandatory in any possible profile. Optional tools may not be required in some profiles.

Table 1 — AAC decoder tools

Tool Name	Required / Optional
Bitstream Formatter	Required
Noiseless Decoding	Required
Inverse quantization	Required
Rescaling	Required
M/S	Optional
Prediction	Optional
Intensity	Optional
Dependently switched coupling	Optional
TNS	Optional
Filterbank / block switching	Required
Gain control	Optional
Independently switched coupling	Optional

1.2 MPEG-2 AAC Tools Overview

The basic structure of the MPEG-2 AAC system is shown in Figure 1 and Figure 2. As is shown in Table 1, there are both required and optional tools in the decoder. The data flow in this diagram is from left to right, top to bottom. The functions of the decoder are to find the description of the quantized audio spectra in the bitstream, decode the quantized values and other reconstruction information, reconstruct the quantized spectra, process the reconstructed spectra through whatever tools are active in the bitstream in order to arrive at the actual signal spectra as described by the input bitstream, and finally convert the frequency domain spectra to the time domain, with or without an optional gain control tool. Following the initial reconstruction and scaling of the spectrum reconstruction, there are many optional tools that modify one or more of the spectra in order to provide more efficient coding. For each of the optional tools that operate in the spectral domain, the option to “pass through” is retained, and in all cases where a spectral operation is omitted, the spectra at its input are passed directly through the tool without modification.

The input to the bitstream demultiplexer tool is the MPEG-2 AAC bitstream. The demultiplexer separates the parts of the MPEG-AAC data stream into the parts for each tool, and provides each of the tools with the bitstream information related to that tool.

The outputs from the bitstream demultiplexer tool are:

- The sectioning information for the noiselessly coded spectra,
- The noiselessly coded spectra,
- The M/S decision information (optional),
- The predictor state information (optional),
- The intensity stereo control information and coupling channel control information (both optional),
- The temporal noise shaping (TNS) information (optional),
- The filterbank control information, and
- The gain control information (optional).

The noiseless decoding tool takes information from the bitstream demultiplexer, parses that information, decodes the Huffman coded data, and reconstructs the quantized spectra and the Huffman and DPCM coded scalefactors.

The inputs to the noiseless decoding tool are:

- The sectioning information for the noiselessly coded spectra, and
- The noiselessly coded spectra.

The outputs of the Noiseless Decoding tool are:

- The decoded integer representation of the scalefactors, and
- The quantized values for the spectra.

The inverse quantizer tool takes the quantized values for the spectra, and converts the integer values to the non-scaled, reconstructed spectra. This quantizer is a non-uniform quantizer.

The input to the Inverse Quantizer tool is:

- The quantized values for the spectra.

The output of the inverse quantizer tool is:

- The un-scaled, inversely quantized spectra.

The rescaling tool converts the integer representation of the scalefactors to the actual values, and multiplies the un-scaled inversely quantized spectra by the relevant scalefactors.

The inputs to the rescaling tool are:

- The decoded integer representation of the scalefactors, and
- The un-scaled, inversely quantized spectra.

The output from the scalefactors tool is:

- The scaled, inversely quantized spectra.

The M/S tool converts spectra pairs from Mid/Side to Left/Right under control of the M/S decision information in order to improve coding efficiency.

The inputs to the M/S tool are:

- The M/S decision information, and
- The scaled, inversely quantized spectra related to pairs of channels.

The output from the M/S tool is:

- The scaled, inversely quantized spectra related to pairs of channels, after M/S decoding.

Note The scaled, inversely quantized spectra of individually coded channels are not processed by the M/S block, rather they are passed directly through the block without modification. If the M/S block is not active, all spectra are passed through this block unmodified.

The prediction tool reverses the prediction process carried out at the encoder. This prediction process re-inserts the redundancy that was extracted by the prediction tool at the encoder, under the control of the predictor state information. This tool is implemented as a second order backward adaptive predictor. The inputs to the prediction tool are:

- The predictor state information, and
- The scaled, inversely quantized spectra.

The output from the prediction tool is:

- The scaled, inversely quantized spectra, after prediction is applied.

Note If the prediction is disabled, the scaled, inversely quantized spectra are passed directly through the block without modification.

The intensity stereo tool implements intensity stereo decoding on pairs of spectra.

The inputs to the intensity stereo tool are:

- The inversely quantized spectra, and
- The intensity stereo control information.

The output from the intensity stereo tool is:

- The inversely quantized spectra after intensity channel decoding.

Note The scaled, inversely quantized spectra of individually coded channels are passed directly through this tool without modification, if intensity stereo is not indicated. The intensity stereo tool and M/S tool are arranged so that the operation of M/S and intensity stereo are mutually exclusive on any given scalefactor band and group of one pair of spectra.

The coupling tool for dependently switched coupling channels adds the relevant data from dependently switched coupling channels to the spectra, as directed by the coupling control information.

The inputs to the coupling tool are:

- The inversely quantized spectra, and
- The coupling control information.

The output from the coupling tool is:

- The inversely quantized spectra coupled with the dependently switched coupling channels.

Note The scaled, inversely quantized spectra are passed directly through this tool without modification, if coupling is not indicated. Depending on the coupling control information, dependently switched coupling channels might either be coupled before or after the TNS processing.

The coupling tool for independently switched coupling channels adds the relevant data from independently switched coupling channels to the time signal, as directed by the coupling control information.

The inputs to the coupling tool are:

- The time signal as output by the filterbank, and
- The coupling control information.

The output from the coupling tool is:

- The time signal coupled with the independently switched coupling channels.

Note The time signal is passed directly through this tool without modification, if coupling is not indicated.

The temporal noise shaping (TNS) tool implements a control of the fine time structure of the coding noise. In the encoder, the TNS process has flattened the temporal envelope of the signal to which it has been applied. In the decoder, the inverse process is used to restore the actual temporal envelope(s), under control of the TNS information. This is done by applying a filtering process to parts of the spectral data.

The inputs to the TNS tool are:

- The inversely quantized spectra, and
- The TNS information.

The output from the TNS block is:

- The inversely quantized spectra.

Note If this block is disabled, the inversely quantized spectra are passed through without modification.

The filterbank / block switching tool applies the inverse of the frequency mapping that was carried out in the encoder. An inverse modified discrete cosine transform (IMDCT) is used for the filterbank tool. The IMDCT can be configured to support either one set of 128 or 1024, or four sets of 32 or 256 spectral coefficients.

The inputs to the filterbank tool are:

- The inversely quantized spectra, and
- The filterbank control information.

The output(s) from the filterbank tool is (are):

- The time domain reconstructed audio signal(s).

When present, the gain control tool applies a separate time domain gain control to each of four frequency bands that have been created by the gain control PQF filterbank in the encoder. Then, it assembles four frequency bands and reconstructs the time waveform through the gain control tool's filterbank.

The inputs to the gain control tool are:

- The time domain reconstructed audio signal(s), and
- The gain control information.

The output(s) from the gain control tool is (are):

- The time domain reconstructed audio signal(s).

If the gain control tool is not active, the time domain reconstructed audio signal(s) are passed directly from the filterbank tool to the output of the decoder. This tool is used for the scalable sampling rate (SSR) profile only.

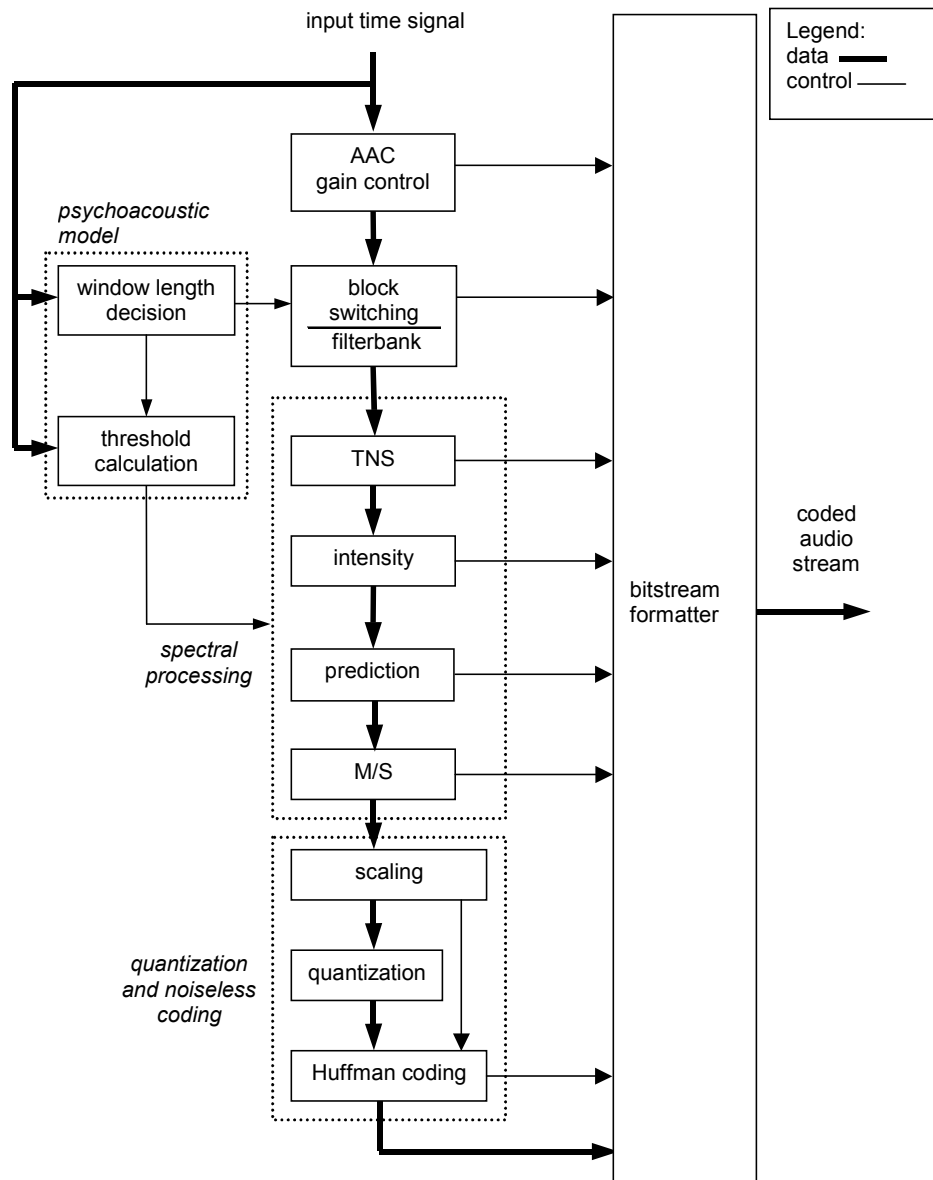

Figure 1 — MPEG-2 AAC Encoder Block Diagram

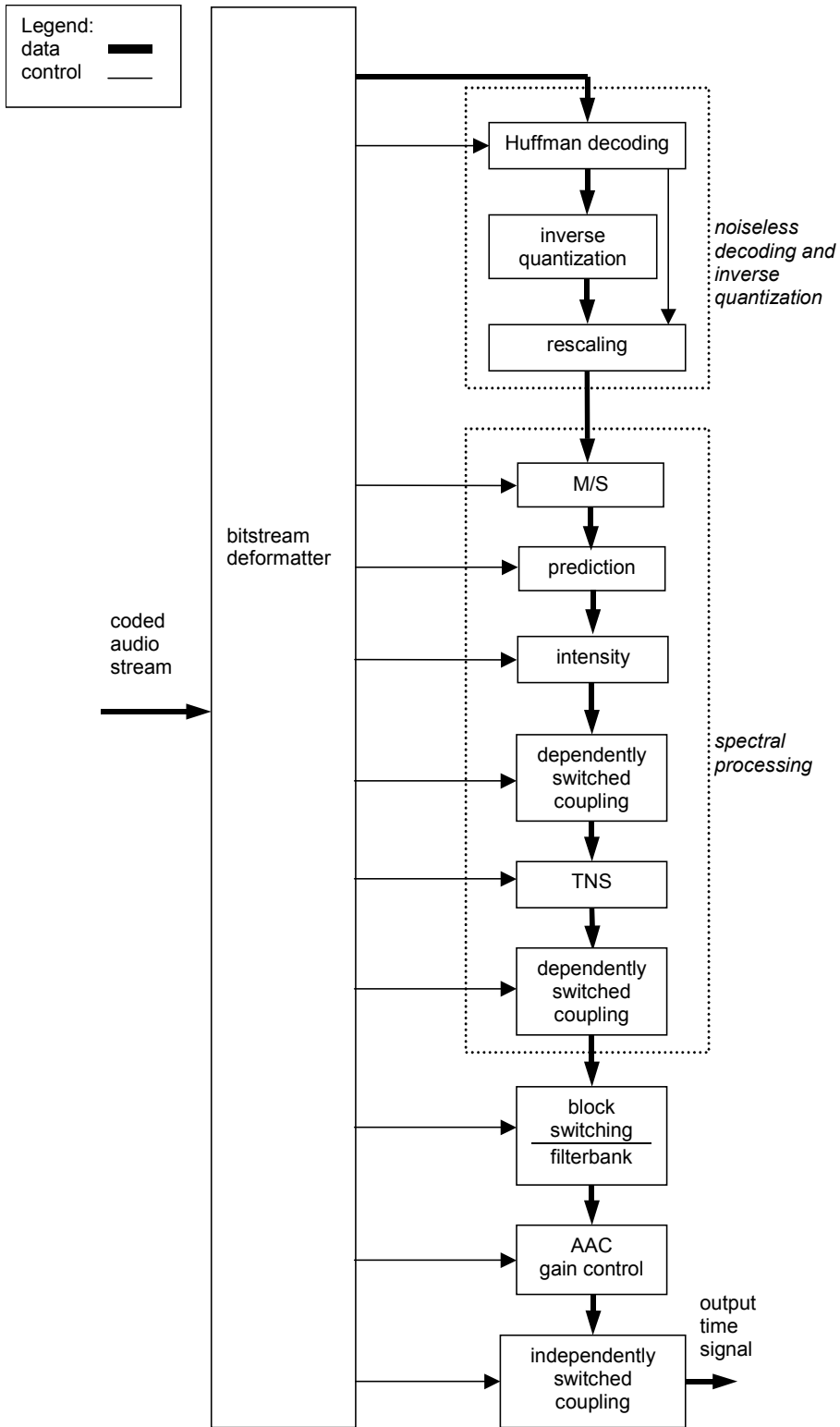

Figure 2 — MPEG-2 AAC Decoder Block Diagram

2 Normative References

The following referenced documents are indispensable for the application of this document. For dated references, only the edition cited applies. For undated references, the latest edition of the referenced document (including any amendments) applies.

ISO/IEC 11172-3: *Information technology — Coding of moving pictures and associated audio for digital storage media at up to about 1,5 Mbit/s — Part 3: Audio*

ISO/IEC 13818-1: *Information technology — Generic coding of moving pictures and associated audio information — Part 1: Systems*

ISO/IEC 13818-3: *Information technology — Generic coding of moving pictures and associated audio information — Part 3: Audio*

ISO/IEC 14496-3: *Information technology — Coding of audio-visual objects — Part 3: Audio*

3 Terms and Definitions

For the purposes of this part of ISO/IEC 13818, the following definitions apply.

3.1

access unit

in the case of compressed audio, an audio access unit

3.2

alias

mirrored signal component resulting from sampling

3.3

analysis filterbank

filterbank in the encoder that transforms a broadband PCM audio signal into a set of spectral coefficients

3.4

ancillary data

part of the bitstream that might be used for transmission of ancillary data

3.5

audio access unit

for AAC, the smallest part of the encoded bitstream which can be decoded by itself, where decoded means "fully reconstructed sound"

NOTE Typically, this is a segment of the encoded bitstream starting after the end of the byte containing the last bit of one ID_END id_syn_ele() through the end of the byte containing the last bit of the next ID_END id_syn_ele.

3.6

audio buffer

buffer in the system target decoder (see ISO/IEC 13818-1) for storage of compressed audio data

3.7

bark

standard unit corresponding to one critical band width of human hearing

3.8

backward compatibility

newer coding standard is backward compatible with an older coding standard if decoders designed to operate with the older coding standard are able to continue to operate by decoding all or part of a bitstream produced according to the newer coding standard

- 3.9
bitrate**
rate at which the compressed bitstream is delivered to the input of a decoder
- 3.10
bitstream
stream**
ordered series of bits that forms the coded representation of the data
- 3.11
bitstream verifier**
process by which it is possible to test and verify that all the requirements specified in this part of ISO/IEC 13818 are met by the bitstream
- 3.12
block companding**
normalizing of the digital representation of an audio signal within a certain time period
- 3.13
byte aligned**
bit in a coded bitstream is byte-aligned if its position is a multiple of 8-bits from either the first bit in the stream for the Audio Data Interchange Format (see 6.1) or the first bit in the syncword for the Audio Data Transport Stream Format (see 6.2)
- 3.14
byte**
sequence of 8 bits
- 3.15
centre channel**
audio presentation channel used to stabilize the central component of the frontal stereo image
- 3.16
channel**
sequence of data representing an audio signal intended to be reproduced at one listening position
- 3.17
coded audio bitstream**
coded representation of an audio signal
- 3.18
coded representation**
data element as represented in its encoded form
- 3.19
compression**
reduction in the number of bits used to represent an item of data
- 3.20
constant bitrate**
operation in which the bitrate is constant from start to finish of the coded bitstream
- 3.21
CRC**
Cyclic Redundancy Check to verify the correctness of data

3.22**critical band**

unit of bandwidth which represents the standard unit of bandwidth expressed in human auditory terms, corresponding to a fixed length on the human cochlea, approximately equal to 100 Hz at low frequencies and 1/3 octave at higher frequencies, above approximately 700 Hz

3.23**data element**

item of data as represented before encoding and after decoding

3.24**decoded stream**

decoded reconstruction of a compressed bitstream

3.25**decoder**

embodiment of a decoding process

3.26**decoding (process)**

process defined in this part of ISO/IEC 13818 that reads an input coded bitstream and outputs decoded audio samples

3.27**digital storage media****DSM**

digital storage or transmission device or system

3.28**discrete cosine transform****DCT**

either the forward discrete cosine transform or the inverse discrete cosine transform, an invertible, discrete orthogonal transformation

3.29**downmix**

matrixing of n channels to obtain less than n channels

3.30**editing**

process by which one or more coded bitstreams are manipulated to produce a new coded bitstream

NOTE Conforming edited bitstreams are defined in this part of ISO/IEC 13818.

3.31**encoder**

embodiment of an encoding process

3.32**encoding (process)**

process, not specified in ISO/IEC 13818, that reads a stream of input audio samples and produces a valid coded bitstream as defined in this part of ISO/IEC 13818

3.33**entropy coding**

variable length lossless coding of the digital representation of a signal to reduce statistical redundancy

3.34

Fast Fourier Transformation

FFT

fast algorithm for performing a discrete Fourier transform (an orthogonal transform)

3.35

filterbank

set of band-pass filters covering the entire audio frequency range

3.36

flag

variable which can take one of only the two values defined in this part of ISO/IEC 13818

3.37

forward compatibility

a newer coding standard is forward compatible with an older coding standard if decoders designed to operate with the newer coding standard are able to decode bitstreams of the older coding standard

3.38

frame

part of the audio signal that corresponds to audio PCM samples from an audio access unit

3.39

F_s

sampling frequency

3.40

Hann window

time function applied sample-by-sample to a block of audio samples before Fourier transformation

3.41

Huffman coding

specific method for entropy coding

3.42

hybrid filterbank

serial combination of subband filterbank and MDCT

3.43

IDCT

Inverse Discrete Cosine Transform

3.44

IMDCT

Inverse Modified Discrete Cosine Transform

3.45

intensity stereo

method of exploiting stereo irrelevance or redundancy in stereophonic audio programmes based on retaining at high frequencies only the energy envelope of the right and left channels

3.46

joint stereo coding

any method that exploits stereophonic irrelevance or stereophonic redundancy

3.47

joint stereo mode

mode of the audio coding algorithm using joint stereo coding

3.48**low frequency enhancement (LFE) channel**

limited bandwidth channel for low frequency audio effects in a multichannel system

3.49**main audio channels**

all channels represented by either `single_channel_element()`'s (see 8.2.1) or `channel_pair_element()`'s (see 8.2.1)

3.50**mapping**

conversion of an audio signal from time to frequency domain by subband filtering and/or by MDCT

3.51**masking**

property of the human auditory system by which an audio signal cannot be perceived in the presence of another audio signal

3.52**masking threshold**

function in frequency and time below which an audio signal cannot be perceived by the human auditory system

3.53**modified discrete cosine transform****MDCT**

transform which has the property of time domain aliasing cancellation

NOTE An analytical expression for the MDCT can be found in C.3.1.2.

3.54**M/S stereo**

method of removing imaging artefacts as well as exploiting stereo irrelevance or redundancy in stereophonic audio programmes based on coding the sum and difference signal instead of the left and right channels

3.55**multichannel**

combination of audio channels used to create a spatial sound field

3.56**multilingual**

presentation of dialogue in more than one language

3.57**non-tonal component**

noise-like component of an audio signal

3.58**Number of Considered Channels****NCC**

number of channels represented by the elements SCE, independently switched CCE and CPE, i.e. once the number of SCEs plus once the number of independently switched CCEs plus twice the number of CPEs, with respect to the naming conventions of the MPEG-AAC decoders and bitstreams, $NCC=A+I$

NOTE This number is used to derive the required decoder input buffer size (see 8.2.3).

3.59**Nyquist sampling**

sampling at or above twice the maximum bandwidth of a signal

3.60

padding

method to adjust the average length of an audio frame in time to the duration of the corresponding PCM samples, by conditionally adding a slot to the audio frame

3.61

parameter

variable within the syntax of this specification which may take one of a range of values. A variable which can take one of only two values is a flag or indicator and not a parameter

3.62

parser

functional stage of a decoder which extracts from a coded bitstream a series of bits representing coded elements

3.63

polyphase filterbank

set of equal bandwidth filters with special phase interrelationships, allowing for an efficient implementation of the filterbank

3.64

prediction error

difference between the actual value of a sample or data element and its predictor

3.65

prediction

use of a predictor to provide an estimate of the sample value or data element currently being decoded

3.66

predictor

linear combination of previously decoded sample values or data elements

3.67

presentation channel

audio channel at the output of the decoder

3.68

presentation unit

in the case of compressed audio, a decoded audio access unit

3.69

program

set of main audio channels, `coupling_channel_element()`'s (see 8.2.1), `lfe_channel_element()`'s (see 8.2.1), and associated data streams intended to be decoded and played back simultaneously

NOTE A program may be defined by default (see 8.5.3.1 and 8.5.3.3) or specifically by a `program_config_element()` (see 8.5.3.2). A given `single_channel_element()` (see 8.2.1), `channel_pair_element()` (see 8.2.1), `coupling_channel_element()`, `lfe_channel_element()` or data channel may accompany one or more programs in any given bitstream.

3.70

psychoacoustic model

mathematical model of the masking behaviour of the human auditory system

3.71

random access

process of beginning to read and decode the coded bitstream at an arbitrary point

3.72**reserved**

when used in the clauses defining the coded bitstream, indicates that the value may be used in the future for ISO/IEC defined extensions

3.73**sampling frequency****F_s**

rate in Hertz which is used to digitize an audio signal during the sampling process

3.74**scalefactor**

factor by which a set of values is scaled before quantization

3.75**scalefactor band**

set of spectral coefficients which are scaled by one scalefactor

3.76**scalefactor index**

numerical code for a scalefactor

3.77**side information**

information in the bitstream necessary for controlling the decoder

3.78**spectral coefficients**

discrete frequency domain data output from the analysis filterbank

3.79**spreading function**

function that describes the frequency spread of masking effects

3.80**stereo-irrelevant**

portion of a stereophonic audio signal which does not contribute to spatial perception

3.81**stuffing (bits)****stuffing (bytes)**

code words that may be inserted at particular locations in the coded bitstream that are discarded in the decoding process whose purpose is to increase the bitrate of the stream which would otherwise be lower than the desired bitrate

3.82**surround channel**

audio presentation channel added to the front channels (L and R or L, R, and C) to enhance the spatial perception

3.83**Syncword**

a 12-bit code embedded in the audio bitstream that identifies the start of a `adts_frame()` (see 6.2, Table 5)

3.84**synthesis filterbank**

filterbank in the decoder that reconstructs a PCM audio signal from subband samples

3.85

tonal component

sinusoid-like component of an audio signal

3.86

variable bitrate

operation in which the bitrate varies with time during the decoding of a coded bitstream

3.87

variable length coding

reversible procedure for coding that assigns shorter code words to frequent symbols and longer code words to less frequent symbols

3.88

variable length code

VLC

code word assigned by variable length encoder (see variable length coding)

3.89

variable length decoder

procedure to obtain the symbols encoded with a variable length coding technique

3.90

variable length encoder

procedure to assign variable length codewords to symbols

4 Symbols and Abbreviations

The mathematical operators used to describe this International Standard are similar to those used in the C programming language. However, integer division with truncation and rounding are specifically defined. The bitwise operators are defined assuming twos-complement representation of integers. Numbering and counting loops generally begin from zero.

4.1 Arithmetic Operators

- + Addition.
- Subtraction (as a binary operator) or negation (as a unary operator).
- ++ Increment.
- Decrement.
- * Multiplication.
- ^ Power.
- / Integer division with truncation of the result toward zero. For example, $7/4$ and $-7/-4$ are truncated to 1 and $-7/4$ and $7/-4$ are truncated to -1 .
- // Integer division with rounding to the nearest integer. Half-integer values are rounded away from zero unless otherwise specified. For example $3//2$ is rounded to 2, and $-3//2$ is rounded to -2 .
- DIV Integer division with truncation of the result towards $-\infty$.

|| Absolute value. $|x| = x$ when $x > 0$
 $|x| = 0$ when $x == 0$
 $|x| = -x$ when $x < 0$

% Modulus operator. Defined only for positive numbers.

Sign() Sign.
 $\text{Sign}(x) = 1$ when $x > 0$
 $\text{Sign}(x) = 0$ when $x == 0$
 $\text{Sign}(x) = -1$ when $x < 0$

INT () Truncation to integer operator. Returns the integer part of the real-valued argument.

NINT () Nearest integer operator. Returns the nearest integer value to the real-valued argument. Half-integer values are rounded away from zero.

sin Sine.

cos Cosine.

exp Exponential.

$\sqrt{\quad}$ Square root.

log₁₀ Logarithm to base ten.

log_e Logarithm to base e.

log₂ Logarithm to base 2.

4.2 Logical Operators

|| Logical OR.

&& Logical AND.

! Logical NOT

4.3 Relational Operators

> Greater than.

>= Greater than or equal to.

< Less than.

<= Less than or equal to.

== Equal to.

!= Not equal to.

max [...,] the maximum value in the argument list.

min [...,] the minimum value in the argument list.

4.4 Bitwise Operators

A twos complement number representation is assumed where the bitwise operators are used.

&	AND
	OR
>>	Shift right with sign extension.
<<	Shift left with zero fill.

4.5 Assignment

= Assignment operator.

4.6 Mnemonics

The following mnemonics are defined to describe the different data types used in the coded bitstream.

bslbf	Bit string, left bit first, where "left" is the order in which bit strings are written in ISO/IEC 13818. Bit strings are written as a string of 1s and 0s within single quote marks, e.g. '1000 0001'. Blanks within a bit string are for ease of reading and have no significance.
L, C, R, LS, RS	Left, center, right, left surround and right surround audio signals
rpchof	Remainder polynomial coefficients, highest order first. (Audio)
uimsbf	Unsigned integer, most significant bit first.
vlclbf	Variable length code, left bit first, where "left" refers to the order in which the VLC codes are written.
window	Number of the actual time slot in case of <code>block_type == 2</code> , <code>0 <= window <= 2</code> . (Audio)

The byte order of multi-byte words is most significant byte first.

4.7 Constants

π	3.14159265358...
e	2.71828182845...

5 Method of Describing Bitstream Syntax

The bitstream retrieved by the decoder is described in clause 6. Each data item in the bitstream is in bold type. It is described by

- its name;
- its length in bits, where "X..Y" indicates that the number of bits is one of the values between X and Y including X and Y. "{X;Y}" means the number of bits is X or Y, depending on the value of other data elements in the bitstream;
- a mnemonic for its type and order of transmission.

The action caused by a decoded data element in a bitstream depends on the value of that data element and on data elements previously decoded. The decoding of the data elements and the definition of the state variables used in their decoding are described in the clauses following the syntax clause. The following constructs are used to express the conditions when data elements are present, and are in normal type:

Note this syntax uses the 'C'-code convention that a variable or expression evaluating to a non-zero value is equivalent to a condition that is true.

<pre>while (condition) { data_element; ... }</pre>	<p>If the condition is true, then the group of data elements occurs next in the data stream. This repeats until the condition is not true.</p>
<pre>do { data_element; ... } while (condition)</pre>	<p>The data element always occurs at least once. The data element is repeated until the condition is not true.</p>
<pre>if (condition) { data_element; ... } else { data_element; ... }</pre>	<p>If the condition is true, then the first group of data elements occurs next in the data stream</p> <p>If the condition is not true, then the second group of data elements occurs next in the data stream.</p>
<pre>switch (expression) { case const-expr: data_element; break; case const-expr: data_element; }</pre>	<p>If the condition formed by the comparison of expression and const-expr. is true, then the data stream continues with the subsequent data elements. An optionally break statement can be used to immediately leave the switch, data elements beyond a break do not occur in the data stream.</p>
<pre>for (expr1; expr2; expr3) { data_element; ... }</pre>	<p>Expr1 is an expression specifying the initialisation of the loop. Normally it specifies the initial state of the counter. Expr2 is a condition specifying a test made before each iteration of the loop. The loop terminates when the condition is not true. Expr3 is an expression that is performed at the end of each iteration of the loop, normally it increments a counter.</p>

Note that the most common usage of this construct is as follows:

<pre>for (i = 0; i < n; i++) { data_element ... }</pre>	<p>The group of data elements occurs n times. Conditional constructs within the group of data elements may depend on the value of the loop control variable i, which is set to zero for the first occurrence, incremented to one for the second occurrence, and so forth.</p>
---	---

As noted, the group of data elements may contain nested conditional constructs. For compactness, the {} may be omitted when only one data element follows.

data_element []	data_element [] is an array of data. The number of data elements is indicated by the context.
data_element [n]	data_element [n] is the n+1th element of an array of data.
data_element [m][n]	data_element [m][n] is the m+1,n+1 th element of a two-dimensional array of data.
data_element [l][m][n]	data_element [l][m][n] is the l+1,m+1,n+1 th element of a three-dimensional array of data.
data_element [m..n]	data_element [m..n] is the inclusive range of bits between bit m and bit n in the data_element.

While the syntax is expressed in procedural terms, it should not be assumed that clause 6 implements a satisfactory decoding procedure. In particular, it defines a correct and error-free input bitstream. Actual decoders must include a means to look for start codes in order to begin decoding correctly.

Definition of nextbits function

The function nextbits() permits comparison of a bit string with the next bits to be decoded in the bitstream.

6 Syntax

6.1 Audio Data Interchange Format, ADIF

Table 2 — Syntax of adif_sequence()

Syntax	No. of bits	Mnemonic
<pre>adif_sequence() { adif_header(); byte_alignment(); raw_data_stream(); }</pre>		

Table 3 — Syntax of adif_header()

Syntax	No. of bits	Mnemonic
adif_header() {		
adif_id;	32	bslbf
copyright_id_present;	1	bslbf
if (copyright_id_present) {		
copyright_id;	72	bslbf
}		
original_copy;	1	bslbf
home;	1	bslbf
bitstream_type;	1	bslbf
bitrate;	23	uimsbf
num_program_config_elements;	4	bslbf
if (bitstream_type == '0') {		
adif_buffer_fullness;	20	uimsbf
}		
for (i = 0; i < num_program_config_elements + 1; i++) {		
program_config_element();		
}		
}		

6.2 Audio Data Transport Stream, ADTS

Table 4 — Syntax of adts_sequence()

Syntax	No. of bits	Mnemonic
adts_sequence() {		
while (nextbits() == syncword) {		
adts_frame();		
}		
}		

Table 5 — Syntax of adts_frame()

Syntax	No. of bits	Mnemonic
adts_frame() {		
adts_fixed_header();		
adts_variable_header();		
if (number_of_raw_data_blocks_in_frame == 0) {		
adts_error_check();		
raw_data_block();		
}		
else {		
adts_header_error_check();		
for (i = 0; i <= number_of_raw_data_blocks_in_frame;		
i++) {		
raw_data_block();		
adts_raw_data_block_error_check();		
}		
}		
}		

Table 6 — Syntax of adts_header_error_check()

Syntax	No. of bits	Mnemonic
adts_header_error_check ()		
{		
if (protection_absent == '0') {		
for (i = 1; i <= number_of_raw_data_blocks_in_frame; i++) {		
raw_data_block_position[i];	16	uimsfb
}		
crc_check;	16	rpchof
}		
}		

Table 7 — Syntax of adts_raw_data_block_error_check()

Syntax	No. of bits	Mnemonic
adts_raw_data_block_error_check()		
{		
if (protection_absent == '0')		
crc_check;	16	rpchof
}		

6.2.1 Fixed Header of ADTS

Table 8 — Syntax of adts_fixed_header()

Syntax	No. of bits	Mnemonic
adts_fixed_header()		
{		
syncword;	12	bslbf
ID;	1	bslbf
layer;	2	uimsbf
protection_absent;	1	bslbf
profile;	2	uimsbf
sampling_frequency_index;	4	uimsbf
private_bit;	1	bslbf
channel_configuration;	3	uimsbf
original_copy;	1	bslbf
home;	1	bslbf
}		

6.2.2 Variable Header of ADTS

Table 9 — Syntax of adts_variable_header()

Syntax	No. of bits	Mnemonic
adts_variable_header()		
{		
copyright_identification_bit;	1	bslbf
copyright_identification_start;	1	bslbf
aac_frame_length;	13	bslbf
adts_buffer_fullness;	11	bslbf
number_of_raw_data_blocks_in_frame;	2	uimsfb
}		

6.2.3 Error Detection

Table 10 — Syntax of `adts_error_check()`

Syntax	No. of bits	Mnemonic
<pre>adts_error_check() { if (protection_absent == '0') crc_check; }</pre>	16	rpchof

6.3 Raw Data

Table 11 — Syntax of `raw_data_stream()`

Syntax	No. of bits	Mnemonic
<pre>raw_data_stream() { while (data_available()) { raw_data_block(); } }</pre>		

Table 12 — Syntax of `raw_data_block()`

Syntax	No. of bits	Mnemonic
<pre>raw_data_block() { while ((id = id_syn_ele) != ID_END) { switch (id) { case ID_SCE: single_channel_element(); break; case ID_CPE: channel_pair_element(); break; case ID_CCE: coupling_channel_element(); break; case ID_LFE: lfe_channel_element(); break; case ID_DSE: data_stream_element(); break; case ID_PCE: program_config_element(); break; case ID_FIL: fill_element(); } } byte_alignment(); }</pre>	3	uimsbf

Table 13 — Syntax of `single_channel_element()`

Syntax	No. of bits	Mnemonic
<code>single_channel_element()</code> { element_instance_tag ; individual_channel_stream(0); }	4	uimsbf

Table 14 — Syntax of `channel_pair_element()`

Syntax	No. of bits	Mnemonic
<code>channel_pair_element()</code> { element_instance_tag ; common_window ; if (common_window) { ics_info(); ms_mask_present ; if (ms_mask_present == 1) { for (g = 0; g < num_window_groups; g++) { for (sfb = 0; sfb < max_sfb; sfb++) { ms_used[g][sfb] ; } } } } individual_channel_stream(common_window); individual_channel_stream(common_window); }	4 1 2 1	uimsbf uimsbf uimsbf uimsbf

Table 15 — Syntax of ics_info()

Syntax	No. of bits	Mnemonic
ics_info()		
{		
ics_reserved_bit;	1	bslbf
window_sequence;	2	uimsbf
window_shape;	1	uimsbf
if (window_sequence == EIGHT_SHORT_SEQUENCE) {		
max_sfb;	4	uimsbf
scale_factor_grouping;	7	uimsbf
}		
else {		
max_sfb;	6	uimsbf
predictor_data_present;	1	uimsbf
if (predictor_data_present) {		
predictor_reset;	1	uimsbf
if (predictor_reset) {		
predictor_reset_group_number;	5	uimsbf
}		
for (sfb = 0; sfb < min(max_sfb, PRED_SFB_MAX); sfb++) {		
prediction_used[sfb];	1	uimsbf
}		
}		
}		
}		

Table 16 — Syntax of individual_channel_stream()

Syntax	No. of bits	Mnemonic
individual_channel_stream(common_window)		
{		
global_gain;	8	uimsbf
if (!common_window)		
ics_info();		
section_data();		
scale_factor_data();		
pulse_data_present;	1	uimsbf
if (pulse_data_present) {		
pulse_data();		
}		
tns_data_present;	1	uimsbf
if (tns_data_present) {		
tns_data();		
}		
gain_control_data_present;	1	uimsbf
if (gain_control_data_present) {		
gain_control_data();		
}		
spectral_data();		
}		

Table 17 — Syntax of section_data()

Syntax	No. of bits	Mnemonic
<pre> section_data() { if (window_sequence == EIGHT_SHORT_SEQUENCE) sect_esc_val = (1<<3) - 1; else sect_esc_val = (1<<5) - 1; for (g = 0; g < num_window_groups; g++) { k = 0; i = 0; while (k < max_sfb) { sect_cb[g][i]; sect_len = 0; while (sect_len_incr == sect_esc_val) { sect_len += sect_esc_val; } sect_len += sect_len_incr; sect_start[g][i] = k; sect_end[g][i] = k+sect_len; for (sfb = k; sfb < k+sect_len; sfb++) sfb_cb[g][sfb] = sect_cb[g][i]; k += sect_len; i++; } num_sec[g] = i; } } </pre>	<p>4</p> <p>{3;5}</p>	<p>uimsbf</p> <p>uimsbf</p>

Table 18 — Syntax of scale_factor_data()

Syntax	No. of bits	Mnemonic
<pre> scale_factor_data() { for (g = 0; g < num_window_groups; g++) { for (sfb = 0; sfb < max_sfb; sfb++) { if (sfb_cb[g][sfb] != ZERO_HCB) { if (is_intensity(g,sfb)) hcod_sf[dpcm_is_position[g][sfb]]; else hcod_sf[dpcm_sf[g][sfb]]; } } } } </pre>	<p>1..19</p> <p>1..19</p>	<p>vlclbf</p> <p>vlclbf</p>

Table 19 — Syntax of tns_data()

Syntax	No. of bits	Mnemonic
tns_data() { for (w = 0; w < num_windows; w++) { n_filt[w]; if (n_filt[w]) coef_res[w]; for (filt = 0; filt < n_filt[w]; filt++) { length[w][filt]; order[w][filt]; if (order[w][filt]) { direction[w][filt]; coef_compress[w][filt]; for (i = 0; i < order[w][filt]; i++) coef[w][filt][i]; } } } }	1..2 1 {4;6} {3;5} 1 1 2..4	uimsbf uimsbf uimsbf uimsbf uimsbf uimsbf

Table 20 — Syntax of spectral_data()

Syntax	No. of bits	Mnemonic
spectral_data() { for (g = 0; g < num_window_groups; g++) { for (i = 0; i < num_sec[g]; i++) { if (sect_cb[g][i] != ZERO_HCB && sect_cb[g][i] <= ESC_HCB) { for (k = sect_sfb_offset[g][sect_start[g][i]; k < sect_sfb_offset[g][sect_end[g][i]];) { if (sect_cb[g][i] < FIRST_PAIR_HCB) { hcod[sect_cb[g][i][w][x][y][z]; if (unsigned_cb[sect_cb[g][i]]) quad_sign_bits; k += QUAD_LEN; } else { hcod[sect_cb[g][i][y][z]; if (unsigned_cb[sect_cb[g][i]]) pair_sign_bits; k += PAIR_LEN; if (sect_cb[g][i] == ESC_HCB) { if (y == ESC_FLAG) hcod_esc_y; if (z == ESC_FLAG) hcod_esc_z; } } } } } } }	1..16 0..4 1..15 0..2 5..21 5..21	vlclbf bslbf vlclbf bslbf vlclbf vlclbf

Table 21 — Syntax of pulse_data()

Syntax	No. of bits	Mnemonic
pulse_data() {		
number_pulse;	2	uimsbf
pulse_start_sfb;	6	uimsbf
for (i = 0; i < number_pulse+1; i++) {		
pulse_offset[i];	5	uimsbf
pulse_amp[i];	4	uimsbf
}		
}		

Table 22 — Syntax of coupling_channel_element()

Syntax	No. of bits	Mnemonic
coupling_channel_element()		
{		
element_instance_tag;	4	uimsbf
ind_sw_cce_flag;	1	uimsbf
num_coupled_elements;	3	uimsbf
num_gain_element_lists = 0;		
for (c = 0; c < num_coupled_elements+1; c++) {		
num_gain_element_lists++;		
cc_target_is_cpe[c];	1	uimsbf
cc_target_tag_select[c];	4	uimsbf
if (cc_target_is_cpe[c]) {		
cc_l[c];	1	uimsbf
cc_r[c];	1	uimsbf
if (cc_l[c] && cc_r[c])		
num_gain_element_lists++;		
}		
}		
cc_domain;	1	uimsbf
gain_element_sign;	1	uimsbf
gain_element_scale;	2	uimsbf
individual_channel_stream(0);		
for (c = 1; c < num_gain_element_lists; c++) {		
if (ind_sw_cce_flag) {		
cge = 1;		
} else {		
common_gain_element_present[c];	1	uimsbf
cge = common_gain_element_present[c];		
}		
if (cge)		
hcod_sf[common_gain_element[c]];	1..19	vlclbf
else {		
for (g = 0; g < num_window_groups; g++) {		
for (sfb = 0; sfb < max_sfb; sfb++) {		
if (sfb_cb[g][sfb] != ZERO_HCB);		
hcod_sf[dpcm_gain_element[c][g][sfb]];	1..19	vlclbf
}		
}		
}		
}		
}		

Table 23 — Syntax of lfe_channel_element()

Syntax	No. of bits	Mnemonic
lfe_channel_element() { element_instance_tag ; individual_channel_stream(0); }	4	uimsbf

Table 24 — Syntax of data_stream_element()

Syntax	No. of bits	Mnemonic
data_stream_element() { element_instance_tag ; data_byte_align_flag ; cnt = count ; if (cnt == 255) { cnt += esc_count ; } if (data_byte_align_flag) { byte_alignment(); } for (i = 0; i < cnt; i++) { data_stream_byte [element_instance_tag][i]; } }	4 1 8 8 8	uimsbf uimsbf uimsbf uimsbf uimsbf

Table 25 — Syntax of program_config_element()

Syntax	No. of bits	Mnemonic
program_config_element() {		
element_instance_tag;	4	uimsbf
profile;	2	uimsbf
sampling_frequency_index;	4	uimsbf
num_front_channel_elements;	4	uimsbf
num_side_channel_elements;	4	uimsbf
num_back_channel_elements;	4	uimsbf
num_lfe_channel_elements;	2	uimsbf
num_assoc_data_elements;	3	uimsbf
num_valid_cc_elements;	4	uimsbf
mono_mixdown_present;	1	uimsbf
if (mono_mixdown_present == 1)		
mono_mixdown_element_number;	4	uimsbf
stereo_mixdown_present;	1	uimsbf
if (stereo_mixdown_present == 1)		
stereo_mixdown_element_number;	4	uimsbf
matrix_mixdown_idx_present;	1	uimsbf
if (matrix_mixdown_idx_present == 1) {		
matrix_mixdown_idx ;	2	uimsbf
pseudo_surround_enable;	1	uimsbf
}		
for (i = 0; i < num_front_channel_elements; i++) {		
front_element_is_cpe[i];	1	bslbf
front_element_tag_select[i];	4	uimsbf
}		
for (i = 0; i < num_side_channel_elements; i++) {		
side_element_is_cpe[i];	1	bslbf
side_element_tag_select[i];	4	uimsbf
}		
for (i = 0; i < num_back_channel_elements; i++) {		
back_element_is_cpe[i];	1	bslbf
back_element_tag_select[i];	4	uimsbf
}		
for (i = 0; i < num_lfe_channel_elements; i++)		
lfe_element_tag_select[i];	4	uimsbf
for (i = 0; i < num_assoc_data_elements; i++)		
assoc_data_element_tag_select[i];	4	uimsbf
for (i = 0; i < num_valid_cc_elements; i++) {		
cc_element_is_ind_sw[i];	1	uimsbf
valid_cc_element_tag_select[i];	4	uimsbf
}		
byte_alignment();		
comment_field_bytes;	8	uimsbf
for (i = 0; i < comment_field_bytes; i++)		
comment_field_data[i];	8	uimsbf
}		

Table 26 — Syntax of fill_element()

Syntax	No. of bits	Mnemonic
fill_element() {		
cnt = count ;	4	uimsbf
if (cnt == 15)		
cnt += esc_count - 1;	8	uimsbf
while (cnt > 0) {		
cnt -= extension_payload(cnt);		
}		
}		

Table 27 — Syntax of gain_control_data()

Syntax	No. of bits	Mnemonic
gain_control_data()		
{		
max_band;	2	uimsbf
if (window_sequence == ONLY_LONG_SEQUENCE) {		
for (bd = 1; bd <= max_band; bd++) {		
for (wd = 0; wd < 1; wd++) {		
adjust_num[bd][wd];	3	uimsbf
for (ad = 0; ad < adjust_num[bd][wd]; ad++) {		
alevcode[bd][wd][ad];	4	uimsbf
alocode[bd][wd][ad];	5	uimsbf
}		
}		
}		
} else if (window_sequence == LONG_START_SEQUENCE)		
{		
for (bd = 1; bd <= max_band; bd++) {		
for (wd = 0; wd < 2; wd++) {		
adjust_num[bd][wd];	3	uimsbf
for (ad = 0; ad < adjust_num[bd][wd]; ad++) {		
alevcode[bd][wd][ad];	4	uimsbf
if (wd == 0)		
alocode[bd][wd][ad];	4	uimsbf
else		
alocode[bd][wd][ad];	2	uimsbf
}		
}		
}		
} else if (window_sequence == EIGHT_SHORT_SEQUENCE) {		
for (bd = 1; bd <= max_band; bd++) {		
for (wd = 0; wd < 8; wd++) {		
adjust_num[bd][wd];	3	uimsbf
for (ad = 0; ad < adjust_num[bd][wd]; ad++) {		
alevcode[bd][wd][ad];	4	uimsbf
alocode[bd][wd][ad];	2	uimsbf
}		
}		
}		
} else if (window_sequence == LONG_STOP_SEQUENCE) {		
for (bd = 1; bd <= max_band; bd++) {		
for (wd = 0; wd < 2; wd++) {		
adjust_num[bd][wd];	3	uimsbf
for (ad = 0; ad < adjust_num[bd][wd]; ad++) {		
alevcode[bd][wd][ad];	4	uimsbf
if (wd == 0)		
alocode[bd][wd][ad];	4	uimsbf
else		
alocode[bd][wd][ad];	5	uimsbf
}		
}		
}		
}		
}		

Table 28 — Syntax of extension_payload()

extension_payload(cnt)		
{		
extension_type;	4	uimsbf
switch (extension_type) {		
case EXT_DYNAMIC_RANGE:		
n = dynamic_range_info();		
return n;		
case EXT_SBR_DATA:		Note 1
return sbr_extension_data(id_aac, 0);		
case EXT_SBR_DATA_CRC:		Note 1
return sbr_extension_data(id_aac, 1);		
case EXT_FILL_DATA:		
fill_nibble; /* must be '0000' */	4	uimsbf
for (i = 0; i < cnt-1; i++)		
fill_byte[i]; /* must be '10100101' */	8	uimsbf
return cnt;		
case default:		
for (i = 0; i < 8*(cnt-1)+4; i++)		
other_bits[i];	1	uimsbf
return cnt;		
}		
}		

Note 1: id_aac is the id_syn_ele of the corresponding AAC element (ID_SCE or ID_CPE) or ID_SCE in case of CCE.

Table 29 — Syntax of dynamic_range_info()

Syntax	No. of bits	Mnemonic
dynamic_range_info() {		
n = 1;		
drc_num_bands = 1;		
pce_tag_present;	1	uimsbf
if (pce_tag_present == 1) {		
pce_instance_tag;	4	uimsbf
drc_tag_reserved_bits;	4	
n++;		
}		
excluded_chns_present;	1	uimsbf
if (excluded_chns_present == 1) {		
n += excluded_channels();		
}		
drc_bands_present ;	1	uimsbf
if (drc_bands_present == 1) {		
drc_band_incr;	4	uimsbf
drc_bands_reserved_bits;	4	uimsbf
n++;		
drc_num_bands = drc_num_bands + drc_band_incr;		
for (i = 0; i < drc_num_bands; i++) {		
drc_band_top[i];	8	uimsbf
n++;		
}		
}		
prog_ref_level_present;	1	uimsbf
if (prog_ref_level_present == 1) {		
prog_ref_level;	7	uimsbf
prog_ref_level_reserved_bits;	1	uimsbf
n++;		
}		
for (i = 0; i < drc_num_bands; i++) {		
dyn_rng_sgn[i];	1	uimsbf
dyn_rng_ctl[i];	7	uimsbf
n++;		
}		
return n;		
}		

Table 30 — Syntax of `excluded_channels()`

Syntax	No. Of bits	Mnemonic
<code>excluded_channels()</code>		
<code>{</code>		
<code> n = 0;</code>		
<code> num_excl_chan = 70;</code>		
<code> for (i = 0; i < 7; i++)</code>		
<code> exclude_mask[i];</code>	1	uimsbf
<code> n++;</code>		
<code> while (additional_excluded_chns[n-1] == 1) {</code>	1	uimsbf
<code> for (i = num_excl_chan; i < num_excl_chan+7; i++)</code>		
<code> exclude_mask[i];</code>	1	uimsbf
<code> n++;</code>		
<code> num_excl_chan += 7;</code>		
<code>}</code>		
<code> return n;</code>		
<code>}</code>		

7 Profiles and Profile Interoperability

7.1 Profiles

There are three profiles identified in the MPEG-2 AAC standard:

Main Profile

Low Complexity Profile

Scalable Sampling Rate Profile

In the `program_config_element()` and `adts_fixed_header()`, a two bit field indicates the profile in use:

Table 31 — Profiles

index	profile
0	Main profile
1	Low Complexity profile (LC)
2	Scalable Sampling Rate profile (SSR)
3	(reserved)

7.1.1 Main

The Main profile is used when memory cost is not significant, and when there is substantial processing power available. With the exception of the gain control tool, all parts of the tools may be used in order to provide the best data compression possible. There shall be only one program (in the sense of what is specified in a `program_config_element()`) in a Main profile bitstream. The program in a Main profile bitstream shall not contain any mono or stereo mixdown elements.

7.1.2 Low Complexity

The Low Complexity profile is used when RAM usage, processing power, and compression requirements are all present. In the low complexity profile, prediction, and gain control tool are not permitted and TNS order is limited. There shall be only one program (in the sense of what is specified in a `program_config_element()`) in a Low Complexity profile bitstream. The program in a Low Complexity profile bitstream shall not contain any mono or stereo mixdown elements.

7.1.3 Scalable Sampling Rate

In the Scalable Sampling Rate profile, the gain-control tool is required. Prediction and coupling channels are not permitted, and TNS order and bandwidth are limited. Gain control is not used in the lowest of the 4 PQF subbands. In the case of a reduced audio bandwidth, the SSR profile will scale accordingly in complexity. There shall be only one program (in the sense of what is specified in a program_config_element()) in a Scalable Sampling Rate profile bitstream. The program in a Scalable Sampling Rate profile bitstream shall not contain any mono or stereo mixdown elements.

7.1.4 Naming Convention for MPEG-2 AAC Decoders and Bitstreams

A decoder or bitstream may be specified as an A.L.I.D Channel <Profile Name> Profile MPEG-2 AAC decoder or bitstream, where A is replaced by the number of main audio channels, L by the number of LFE channels, I by the number of independently switched coupling channels, D by the number of dependently switched coupling channels, and Profile Name by the actual profile name. An example would be a 5.1.1.1 Channel Main Profile MPEG-2 AAC Decoder, indicating a decoder capable of decoding 5 main audio channels, one LFE channel, and one each independently and dependently switched CCE, with each of the channels using the profile specified. This can be abbreviated as M.5.1.1.1 where the "M" indicates a main profile decoder. Similarly, a Low Complexity decoder can be specified by a leading "L", and an SSR profile by an "S".

7.1.4.1 Naming Convention for MPEG-2 AAC + MPEG-4 SBR Decoders and Bitstreams

A decoder or bitstream conforming additionally to the MPEG-4 AOT SBR at a certain level may be referenced in a similar manner by appending "+ SBR / X [HQ/LP]" to the name, where X is replaced with the level of the HE-AAC profile decoder/bitstream with the same characteristics as specified by ISO/IEC 14496-3. An example would be a 5.1.1.1 Channel Main Profile MPEG-2 AAC + SBR / 5 HQ Decoder.

7.1.5 Minimum Decoder Capability for Specified Number of Main Audio Channels and Profile

To insure a certain level of interoperability the following minimum decoder capabilities for decoders of a given profile and number of main audio channels are specified.

Table 32 — Profile dependent minimum decoder capabilities in terms of channel configuration

Number of Main Audio Channels	Main Profile Capability	Low Complexity Profile Capability	SSR Profile Capability
1	1.0.0.0	1.0.0.0	1.0.0.0
2	2.0.0.0	2.0.0.0	2.0.0.0
3	3.0.1.0	3.0.0.1	3.0.0.0
4	4.0.1.0	4.0.0.1	4.0.0.0
5	5.1.1.1	5.1.0.1	5.1.0.0
7	7.1.1.2	7.1.0.2	7.1.0.0

7.1.6 Profile Dependent Tool Parameters

Maximum TNS order and bandwidth:

According to the profile in use, the value for the constant TNS_MAX_ORDER is set as follows for long windows: For the main profile the constant TNS_MAX_ORDER is 20, for the low complexity profile and the scalable sampling rate profile the constant TNS_MAX_ORDER is 12. For short windows, the constant TNS_MAX_ORDER is 7 for all profiles.

According to the sampling rate and profile in use, the value for the constant TNS_MAX_BANDS is set as follows:

Table 33 — Profile and sampling rate dependent definition of TNS_MAX_BANDS

Sampling Rate [Hz]	Low Complexity / Main Profile (long windows)	Low Complexity / Main Profile (short windows)	Scalable Sampling Rate Profile (long windows)	Scalable Sampling Rate Profile (short windows)
96000	31	9	28	7
88200	31	9	28	7
64000	34	10	27	7
48000	40	14	26	6
44100	42	14	26	6
32000	51	14	26	6
24000	46	14	29	7
22050	46	14	29	7
16000	42	14	23	8
12000	42	14	23	8
11025	42	14	23	8
8000	39	14	19	7

7.2 Profile Interoperability

7.2.1 Interoperability of Bitstreams and Decoders

Any bitstream of a given profile (see Table 34) whose number of main audio channels, LFE channels, independent coupling channels, and dependent coupling channels is less than or equal to the corresponding number of channels supported by a decoder of the same profile can be decoded by that decoder.

Table 34 describes the interoperability of the three profiles.

Table 34 — Profile Interoperability

Decoder Profile	Encoder Profile		
	Main Profile	LC Profile	SSR Profile
Main Profile	yes	yes	no *
LC Profile	no	yes	no *
SSR Profile	no	no **	yes

*In Table 34, these entries can be decoded if the main or LC profile decoder is able to parse, but not decode, the gain control information, but the reconstructed audio will have a limited bandwidth.

**In Table 33, this entry can be decoded, but the bandwidth of the decoded signal will be limited to approximately 5 kHz, corresponding to the nonaliased portion of the first PQMF filter band.

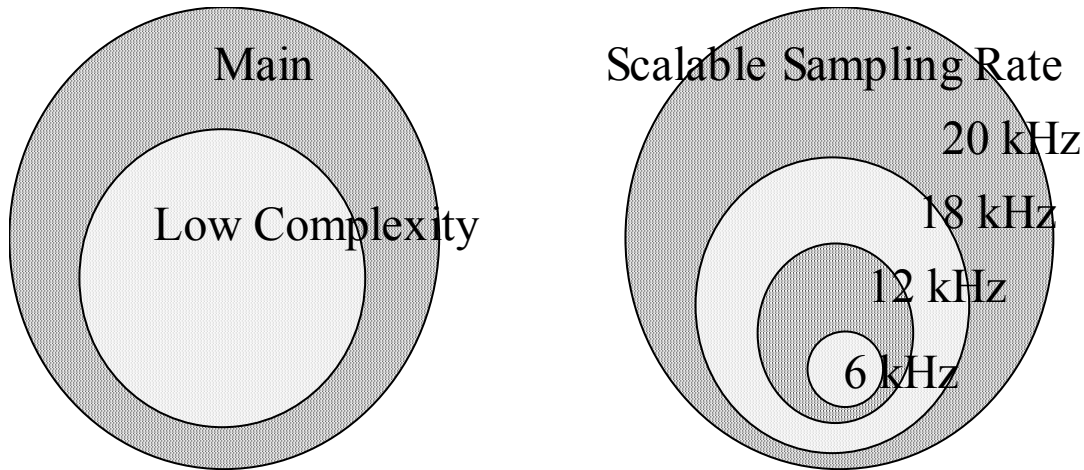

Figure 3 — Profile Interoperability

8 Overall Data Structure

8.1 AAC Interchange Formats

8.1.1 Overview

The `raw_data_block()` contains all data which belongs to the audio (including ancillary data). Beyond that, additional information like `sampling_frequency` is needed to fully describe an audio sequence. The Audio Data Interchange Format (ADIF) contains all elements that are necessary to describe a bitstream according to this standard.

For specific applications some or all of the syntax elements like those specified in the header of the ADIF, e.g. `sampling_rate`, may be known to the decoder by other means and hence do not appear in the bitstream.

Furthermore, additional information that varies from block to block (e.g. to enhance the parsability or error resilience) may be required. Therefore transport streams may be designed for a specific application and are not specified in this standard. However, one non-normative transport stream, called Audio Data Transport Stream (ADTS), is described. It may be used for applications in which the decoder can parse this stream.

8.1.2 Audio Data Interchange Format (ADIF)

8.1.2.1 Overview

The Audio Data Interchange Format (ADIF) contains one header at the start of the sequence followed by a `raw_data_stream()`. The `raw_data_stream()` may not contain any further `program_config_element()`'s.

As such, the ADIF is useful only for systems with a defined start and no need to start decoding from within the audio data stream, such as decoding from disk file. It can be used as an interchange format in that it contains all information necessary to decode and play the audio data.

8.1.2.2 Definitions

8.1.2.2.1 Data Functions

<code>adif_sequence()</code>	a sequence according to the Audio Data Interchange Format (Table 2).
<code>adif_header()</code>	header of the Audio Data Interchange Format located at the beginning of an <code>adif_sequence</code> (Table 3).
<code>byte_alignment()</code>	Align with respect to the first bit of the header.
<code>raw_data_stream()</code>	see subclause 8.2.1 and Table 11.
<code>program_config_element()</code>	contains information about the configuration for one program (Table 3). See subclause 8.5.

8.1.2.2.2 Data Elements

adif_id	ID that indicates the Audio Data Interchange Format. Its value is 0x41444946 (most significant bit first), the ASCII representation of the string „ADIF“ (Table 3).
copyright_id_present	indicates whether copyright_id is present or not (Table 3).
copyright_id	The field consists of an 8-bit copyright_identifier , followed by a 64-bit copyright_number (Table 3). The copyright identifier is given by a Registration Authority as designated by SC 29. The copyright_number is a value which identifies uniquely the copyrighted material. See ISO/IEC 13818-3, definition of data element copyright_identification_bit .
original_copy	see ISO/IEC 11172-3, definition of data element copyright .
home	see ISO/IEC 11172-3, definition of data element original/copy .
bitstream_type	a flag indicating the type of a bitstream (Table 3): <ul style="list-style-type: none"> ‘0’ constant rate bitstream. This bitstream may be transmitted via a channel with constant rate ‘1’ variable rate bitstream. This bitstream is not designed for transmission via constant rate channels
bitrate	a 23 bit unsigned integer indicating either the bitrate of the bitstream in bits/sec in case of constant rate bitstream or the maximum peak bitrate (measured per frame) in case of variable rate bitstreams. A value of 0 indicates that the bitrate is not known (Table 3).
num_program_config_element	number of <code>program_config_element()</code> ’s specified for this <code>adif_sequence()</code> is equal to <code>num_program_config_element+1</code> (Table 3). The minimum value is 0 indicating 1 <code>program_config_element()</code> .
adif_buffer_fullness	state of the bit reservoir after encoding the first <code>raw_data_block()</code> in the <code>adif_sequence()</code> . It is transmitted as the number of available bits in the bit reservoir (Table 3).

8.1.2.2.3 Help Elements

data_available() Function that returns '1' as long as data is available, otherwise '0'.

8.1.3 Audio Data Transport Stream (ADTS)

8.1.3.1 Overview

The Audio Data Transport Stream (ADTS) is similar to syntax used in ISO/IEC 11172-3 and ISO/IEC 13818-3. This will be recognized by ISO/IEC 11172-3 and ISO/IEC 13818-3 decoders as a "Layer 4" bitstream.

The fixed header of the ADTS contains the syncword plus all parts of the header which are necessary for decoding and which do not change from frame to frame. The variable header of the ADTS contains header data which changes from frame to frame.

8.1.3.2 Definitions

8.1.3.2.1 Data Functions

adts_sequence() a sequence according to Audio Data Transport Stream ADTS (Table 4).

adts_frame() an ADTS frame, consisting of a fixed header, a variable header, an optional error check and a specified number of *raw_data_block()*'s (Table 5).

adts_fixed_header() fixed header of ADTS. The information in this header does not change from frame to frame. It is repeated every frame to allow random access into a bitstream bitstream (Table 8).

adts_variable_header() variable header of ADTS. This header is transmitted every frame as well as the fixed header, but contains data that changes from frame to frame (Table 9).

adts_error_check() The following bits are protected and fed into the CRC algorithm in order of their appearance:

- all bits of *adts_fixed_header()*
- all bits of *adts_variable_header()*
- first 192 bits of any
 - *single_channel_element()*
 - *channel_pair_element()*
 - *coupling_channel_element()*
 - *lfe_channel_element()*
- First 128 bits of the second *individual_channel_stream()* in the *channel_pair_element()* must be protected.
- All information in any *program_config_element()* or *data_stream_element()* must be protected.

For any element where the specified protection length of 128 or 192 bits exceeds its actual length, the element is zero padded to the specified protection length for CRC calculation.

The `id_syn_ele` bits shall be excluded from CRC protection. If the length of a CPE is shorter than 192 bits, zero data are appended to achieve the length of 192 bits. Furthermore, if the first ICS of the CPE ends at the N th bit ($N < 192$), the first $(192 - N)$ bits of the second ICS are protected twice, each time in order of their appearance. For example, if the second ICS starts at the 190th bit of CPE, the first 3 bits of the second ICS are protected twice. Finally, if the length of the second ICS is shorter than 128 bits, zero data are appended to achieve the length of 128 bits.

`adts_header_error_check()`

The following bits are protected and fed into the CRC algorithm in order of their appearance:

- all bits of `adts_fixed_header()`
- all bits of `adts_variable_header()`
- all bits of every `raw_data_block_position[i]`.

`adts_raw_data_block_error_check()`

With regard to the i -th `adts_raw_data_block_error_check()`, the bits of the i -th `raw_data_block()` are protected and fed into the CRC algorithm in order of their appearance according to what is specified with regard to the `adts_error_check()` with the exception that no header bits are considered.

`raw_data_block()`

see subclause 8.2.1 and Table 12.

8.1.3.2.2 Data Elements

`raw_data_block_position[i]`

Start position of the i -th `raw_data_block()` in the `adts_frame()`, measured as an offset in bytes from the start position of the first `raw_data_block()` in the `adts_frame()`.

`crc_check`

CRC error detection data generated as described in ISO/IEC 11172-3, subclause 2.4.3.1 (Table 6, Table 7 and Table 10).

`syncword`

The bit string '1111 1111 1111'. See ISO/IEC 11172-3, subclause 2.4.2.3 (Table 8).

`ID`

MPEG identifier, set to '1'. See ISO/IEC 11172-3, subclause 2.4.2.3 (Table 8).

`layer`

Indicates which layer is used. Set to '00'. See ISO/IEC 11172-3, subclause 2.4.2.3 (Table 8).

`protection_absent`

Indicates whether `error_check()` data is present or not. Same as syntax element 'protection_bit' in ISO/IEC 11172-3, subclause 2.4.1 and 2.4.2 (Table 8).

`profile`

profile used. See clause 2 (Table 8).

`sampling_frequency_index`

indicates the sampling frequency used according to the following table (Table 8):

Table 35 — Sampling frequency dependent on `sampling_frequency_index`

<code>sampling_frequency_index</code>	sampling frequency [Hz]
0x0	96000
0x1	88200
0x2	64000
0x3	48000
0x4	44100
0x5	32000
0x6	24000
0x7	22050
0x8	16000
0x9	12000
0xa	11025
0xb	8000
0xc	reserved
0xd	reserved
0xe	reserved
0xf	reserved

`private_bit`

see ISO/IEC 11172-3, subclause 2.4.2.3 (Table 8).

`channel_configuration`

indicates the channel configuration used. If `channel_configuration` is greater than 0, the channel configuration is given in Table 42, see subclause 8.5.3.1. If `channel_configuration` equals 0, the channel configuration is not specified in the header and must be given by a `program_config_element()` following as first syntactic element in the first `raw_data_block()` after the header (see subclause 8.5.3.2), or by the implicit configuration (see subclause 8.5.3.3) or must be known in the application (Table 8).

`original_copy`

see definition in 8.1.2.2.2.

`home`

see definition in 8.1.2.2.2.

`copyright_identification_bit`

One bit of the 72-bit copyright identification field (see `copyright_id` above). The bits of this field are transmitted frame by frame; the first bit is indicated by the `copyright_identification_start` bit set to '1'. The field consists of an 8-bit `copyright_identifier`, followed by a 64-bit `copyright_number`. The `copyright_identifier` is given by a Registration Authority as designated by SC29. The `copyright_number` is a value which identifies uniquely the copyrighted material. See ISO/IEC 13818-3, subclause 2.5.2.13 (Table 9).

`copyright_identification_start`

One bit to indicate that the `copyright_identification_bit` in this audio frame is the first bit of the 72-bit copyright identification. If no copyright identification is transmitted, this bit should be kept '0'. '0' no start of copyright identification in this audio frame '1' start of copyright identification in this audio frame See ISO/IEC 13818-3, subclause 2.5.2.13 (Table 9).

`aac_frame_length`

Length of the frame including headers and `error_check` in bytes (Table 9).

`adts_buffer_fullness`

state of the bit reservoir in the course of encoding the ADTS frame, up to and including the first `raw_data_block()` and the

optionally following `adts_raw_data_block_error_check()`. It is transmitted as the number of available bits in the bit reservoir divided by NCC divided by 32 and truncated to an integer value (Table 9). A value of hexadecimal 7FF signals that the bitstream is a variable rate bitstream. In this case, buffer fullness is not applicable.

number_of_raw_data_blocks_in_frame Number of `raw_data_block()`'s that are multiplexed in the `adts_frame()` is equal to `number_of_raw_data_blocks_in_frame + 1`. The minimum value is 0 indicating 1 `raw_data_block()` (Table 9).

8.2 Raw Data

8.2.1 Definitions

8.2.1.1 Data Functions

`raw_data_stream()`

sequence of `raw_data_block()`'s.

`raw_data_block()`

block of raw data that contains audio data for a time period of 1024 samples, related information and other data. There are seven syntactic elements, identified by the data element `id_syn_ele`. The `audio_channel_element()`'s in one `raw_data_stream()` and one `raw_data_block()` must have one and only one sampling rate. In the `raw_data_block()`, several instances of the same syntactic element may occur, but must have a different 4 bit `element_instance_tag`, except for `data_stream_element()`'s and `fill_element()`'s. Therefore, in one `raw_data_block()`, there can be from 0 to at most 16 instances of any syntactic element, except for `data_stream_element()`'s and `fill_element()`'s, where this limitation does not apply. If multiple `data_stream_element()`'s occur which have the same `element_instance_tag` then they are part of the same data stream. The `fill_element()` has no `element_instance_tag` (since the content does not require subsequent reference) and can occur any number of times. The end of a `raw_data_block()` is indicated with a special `id_syn_ele` (TERM), which may occur only once in a `raw_data_block()`. (Table 12).

`single_channel_element()`

abbreviation SCE. Syntactic element of the bitstream containing coded data for a single audio channel. A `single_channel_element()` basically consists of an `individual_channel_stream()`. There may be up to 16 such elements per raw data block, each one must have a unique `element_instance_tag` (Table 13).

`channel_pair_element()`

abbreviation CPE. Syntactic element of the bitstream containing data for a pair of channels. A `channel_pair_element()` consists of two `individual_channel_stream()`'s and additional joint channel coding information. The two channels may share common side information. The `channel_pair_element()` has the same restrictions as the single channel element as far as `element_instance_tag`, and number of occurrences (Table 14).

`coupling_channel_element()`

Abbreviation CCE. Syntactic element that contains audio data for a coupling channel. A coupling channel represents the information for multi-channel intensity for one block, or alternately for dialogue for multilingual programming. The rules for number

of `coupling_channel_element()`'s and instance tags are as for `single_channel_element()`'s (Table 22). See subclause 12.3.

`lfe_channel_element()` Abbreviation LFE. Syntactic element that contains a low sampling frequency enhancement channel. The rules for the number of `lfe_channel_element()`'s and instance tags are as for `single_channel_element()`'s (Table 23). See subclause 8.4.

`audio_channel_element()` generic term for `single_channel_element()`, `channel_pair_element()`, `coupling_channel_element()` and `lfe_channel_element()`.

`program_config_element()` Abbreviation PCE. Syntactic element that contains program configuration data. The rules for the number of `program_config_element()`'s and `element_instance_tag`'s are the same as for `single_channel_element()`'s (Table 25). PCE's must come before all other syntactic elements in a `raw_data_block()`. See subclause 8.5.

`fill_element()` Abbreviation FIL. Syntactic element that contains fill data. There may be any number of fill elements, that can come in any order in the raw data block (Table 26). See subclause 8.7.

`data_stream_element()` Abbreviation DSE. Syntactic element that contains data. Again, there are 16 `element_instance_tags`. There is, however, no restriction on the number of `data_stream_element()`'s with any one instance tag, as a single data stream may continue across multiple `data_stream_element()`'s with the same instance tag (Table 24). See subclause 8.5.3.

`byte_alignment()` Align with respect to the first bit of the `raw_data_block()`.

8.2.2 Data Elements

`id_syn_ele` a data element that identifies either a syntactic element or the end of a `raw_data_block()` (Table 12):

Table 36 — Syntactic element identification

ID name	encoding	Abbreviation	Syntactic Element
ID_SCE	0x0	SCE	<code>single_channel_element()</code>
ID_CPE	0x1	CPE	<code>channel_pair_element()</code>
ID_CCE	0x2	CCE	<code>coupling_channel_element()</code>
ID_LFE	0x3	LFE	<code>lfe_channel_element()</code>
ID_DSE	0x4	DSE	<code>data_stream_element()</code>
ID_PCE	0x5	PCE	<code>program_config_element()</code>
ID_FIL	0x6	FIL	<code>fill_element()</code>
ID_END	0x7	TERM	

element_instance_tag Unique instance tag for syntactic elements other than `fill_element()`. All syntactic elements containing instance tags may occur more than once, but, except for `data_stream_element()`'s, must have a unique `element_instance_tag` in each `raw_data_block()`. This tag is also used to reference audio syntactic elements in `single_channel_element()`'s, `channel_pair_element()`'s, `lfe_channel_element()`'s, `data_channel_element()`'s, and `coupling_channel_element()`'s inside a `program_config_element()`, and provides the possibility of up to 16 independent `program_config_element()`'s (Table 13, Table 14, Table 22, Table 23, Table 24, Table 25, Table 26).

8.2.3 Buffer Requirements

8.2.3.1 Minimum Decoder Input Buffer

The following rules are used to calculate the maximum number of bits in the input buffer both for the bitstream as a whole, for any given program, or for any given SCE/CPE/CCE:

The input buffer size is 6144 bits per SCE or independently switched CCE, plus 12288 bits per CPE (6144*NCC). Both the total buffer and the individual buffer sizes are limited, so that the buffering limit can be calculated for either the entire bitstream, any entire program, or the individual audio_channel_element()'s permitting the decoder to break a multichannel bitstream into separate mono and stereo bitstreams which are decoded by separate mono and stereo decoders, respectively. All bits for LFE's or dependent CCE's must be supplied from the total buffer requirements based on the independent CCE's, SCE's, and CPE's. Furthermore, all bits required for any DSE's, PCE's, FIL's, or fixed headers, variable headers, byte_alignment, and CRC must also be supplied from the same total buffer requirements.

8.2.3.2 Bit Reservoir

The bit reservoir is controlled at the encoder. The maximum bit reservoir in the encoder depends on the NCC and the mean bitrate. The maximum bit reservoir size for constant rate channels can be calculated by subtracting the mean number of bits per block from the minimum decoder input buffer size. For example, at 96 kbit/s for a stereo signal at 44.1 kHz sampling frequency the mean number of bits per block (mean_framelength) is (96000 bit/s / 44100 1/s * 1024) = 2229.1156... . This leads to a maximum bit reservoir size (max_bit_reservoir) of INT (12288 bit - 2229.1156...) = 10058. For variable bitrate channels the encoder must operate in a way that the input buffer requirements do not exceed the minimum decoder input buffer.

The state of the bit reservoir (bit_reservoir_state) is transmitted in the buffer_fullness field, either as the state of the bit reservoir truncated to an integer value (adif_buffer_fullness) or as the state of the bit reservoir divided by NCC divided by 32 and truncated to an integer value (adts_buffer_fullness).

The bit_reservoir_state of subsequent frames can be derived as follows:

$$bit_reservoir_state[frame] = bit_reservoir_state[frame - 1] + mean_framelength - framelength[frame]$$

Framelengths have to be adjusted such that the following restriction is met

$$0 \leq bit_reservoir_state[frame] \leq max_bit_reservoir$$

8.2.3.3 Maximum Bitrate

Maximum bitrate:

The maximum bitrate depends on the audio sampling rate. It can be calculated based on the minimum input buffer size according to the formula:

$$\frac{6144 \frac{bit}{block}}{1024 \frac{samples}{block}} \cdot sampling_frequency \cdot NCC$$

Table 37 gives some examples of the maximum bitrates per channel depending on the used sampling frequency.

Table 37 — Maximum bitrate depending on the sampling frequency

sampling frequency	maximum bitrate / NCC
48 kHz	288 kbit/s
44.1 kHz	264.6 kbit/s
32 kHz	192 kbit/s

8.2.4 Decoding Process

Assuming that the start of a raw_data_block() is known, it can be decoded without any additional „transport-level“ information and produces 1024 audio samples per output channel. The sampling rate of the audio signal, as specified by the **sampling_frequency_index**, may be specified in a program_config_element() or it may be implied in the specific application domain. In the latter case, the **sampling_frequency_index** must be deduced in order for the bitstream to be parsed.

Since a given sampling frequency is associated with only one sampling frequency table, and since maximum flexibility is desired in the range of possible sampling frequencies, the following Table shall be used to associate an implied sampling frequency with the desired sampling frequency dependent tables.

Table 38 — Sampling frequency mapping

Frequency range (in Hz)	Use tables for sampling frequency (in Hz)
$f \geq 92017$	96000
$92017 > f \geq 75132$	88200
$75132 > f \geq 55426$	64000
$55426 > f \geq 46009$	48000
$46009 > f \geq 37566$	44100
$37566 > f \geq 27713$	32000
$27713 > f \geq 23004$	24000
$23004 > f \geq 18783$	22050
$18783 > f \geq 13856$	16000
$13856 > f \geq 11502$	12000
$11502 > f \geq 9391$	11025
$9391 > f$	8000

The raw_data_stream supports encoding for both constant rate and variable rate channels. In each case the structure of the bitstream and the operation of the decoder are identical except for some minor qualifications. For constant rate channels, the encoder may have to insert a FIL element to adjust the rate upwards to exactly the desired rate. A decoder reading from a constant rate channel must accumulate a minimum number of bits in its input buffer prior to the start of decoding so that output buffer underrun does not occur. In the case of variable rate, demand read channels, each raw_data_block() can have the minimum length (rate) such that the desired audio quality is achieved, and in the decoder there is no minimum input data requirement prior to the start of decoding.

Examples of the simplest possible bitstreams are:

bitstream segment

<SCE><TERM><SCE><TERM>...
 <CPE><TERM><CPE><TERM>...
 <SCE><CPE><CPE><LFE><TERM><SCE><CPE><CPE><LFE><TERM>...

output signal

mono signal
 stereo signal
 5.1 channel signal

where angle brackets (< >) are used to delimit syntactic elements. For the mono signal each SCE must have the same value in its **element_instance_tag**, and similarly, for the stereo signal each CPE must have the same value in its **element_instance_tag**. For the 5.1 channel signal each SCE must have the same value in

its **element_instance_tag**, each CPE associated with the front channel pair must have the same value in its **element_instance_tag**, and each CPE associated with the back channel pair must have the same value in its **element_instance_tag**.

If these bitstreams are to be transmitted over a constant rate channel then they might include a `fill_element()` to adjust the instantaneous bitrate. In this case an example of a coded stereo signal is

```
<CPE><FIL><TERM><CPE><FIL><TERM>...
```

If the bitstreams are to carry ancillary data and run over a constant rate channel then an example of a coded stereo signal is

```
<CPE><DSE><FIL><TERM><CPE><DSE><FIL><TERM>...
```

All `data_stream_element()`'s have the same `element_instance_tag` if they are part of the same data stream.

8.3 Single Channel Element (SCE), Channel Pair Element (CPE) and Individual Channel Stream (ICS)

8.3.1 Definitions

8.3.1.1 Data Elements

common_window	a flag indicating whether the two <code>individual_channel_stream()</code> 's share a <code>ics_info()</code> or not. In case of sharing, the <code>ics_info()</code> is part of the <code>channel_pair_element()</code> and must be used for both channels. Otherwise, the <code>ics_info()</code> is part of each <code>individual_channel_stream()</code> (Table 14).
ics_reserved_bit	flag reserved for future use. Shall be '0'.
window_sequence	indicates the sequence of windows as defined in Table 44 (Table 15).
window_shape	A 1 bit field that determines what window is used for the trailing part of this analysis window (Table 15).
max_sfb	number of scalefactor bands transmitted per group (Table 15).
scale_factor_grouping	A bit field that contains information about grouping of short spectral data (Table 15).

8.3.1.2 Data Functions

<code>individual_channel_stream()</code>	contains data necessary to decode one channel (Table 16).
<code>ics_info()</code>	contains side information necessary to decode an <code>individual_channel_stream()</code> . The <code>individual_channel_stream()</code> 's of a <code>channel_pair_element()</code> may share one common <code>ics_info()</code> (Table 15).

8.3.1.3 Help Elements

<i>scalefactor window band</i>	term for scalefactor bands within a window, given in Table 45 to Table 57.
<i>scalefactor band</i>	term for scalefactor band within a group. In the case of EIGHT_SHORT_SEQUENCE and grouping a scalefactor band

may contain several scalefactor window bands of corresponding frequency. For all other window_sequences scalefactor bands and scalefactor window bands are identical.

<i>g</i>	group index.
<i>win</i>	window index within group.
<i>sfb</i>	scalefactor band index within group.
<i>swb</i>	scalefactor window band index within window.
<i>bin</i>	coefficient index.
<i>num_window_groups</i>	number of groups of windows which share one set of scalefactors.
<i>window_group_length[g]</i>	number of windows in each group.
<i>bit_set(bit_field,bit_num)</i>	function that returns the value of bit number bit_num of a bit_field (most right bit is bit 0).
<i>num_windows</i>	number of windows of the actual window sequence.
<i>num_swb_long_window</i>	number of scalefactor bands for long windows. This number has to be selected depending on the sampling frequency. See subclause 8.9.
<i>num_swb_short_window</i>	number of scalefactor window bands for short windows. This number has to be selected depending on the sampling frequency. See subclause 8.9.
<i>num_swb</i>	number of scalefactor window bands for shortwindows in case of EIGHT_SHORT_SEQUENCE, number of scalefactor window bands for long windows otherwise.
<i>swb_offset_long_window[swb]</i>	Table containing the index of the lowest spectral coefficient of scalefactor band sfb for long windows. This Table has to be selected depending on the sampling frequency. See subclause 8.9.
<i>swb_offset_short_window[swb]</i>	Table containing the index of the lowest spectral coefficient of scalefactor band sfb for short windows. This Table has to be selected depending on the sampling frequency. See subclause 8.9.
<i>swb_offset[swb]</i>	Table containing the index of the lowest spectral coefficient of scalefactor band sfb for short windows in case of EIGHT_SHORT_SEQUENCE, otherwise for long windows.
<i>sect_sfb_offset[g][section]</i>	Table that gives the number of the start coefficient for the section_data() within a group. This offset depends on the window_sequence and scale_factor_grouping.
<i>sampling_frequency_index</i>	see subclause 8.1.2.1.

8.3.2 Decoding Process

8.3.2.1 Decoding a single_channel_element() and channel_pair_element()

A single_channel_element() is composed of an element_instance_tag and an individual_channel_stream. In this case ics_info() is always located in the individual_channel_stream.

A channel_pair_element() begins with an element_instance_tag and common_window flag. If the common_window equals '1', then ics_info() is shared amongst the two individual_channel_stream elements and the MS information is transmitted. If common_window equals '0', then there is an ics_info() within each individual_channel_stream and there is no MS information.

8.3.2.2 Decoding an individual_channel_stream()

In the individual_channel_stream, the order of decoding is:

```

get global_gain

get ics_info() (parse bitstream if common information is not present)

get section_data()

get scalefactor_data(), if present

get pulse_data(), if present

get tns_data(), if present

get gain_control_data(), if present

get spectral_data(), if present.
```

The process of recovering pulse_data is described in clause 9, tns_data in clause 14, and gain_control data in clause 16. An overview of how to decode ics_info() (subclause 8.3), section data (clause 9), scalefactor data (clause 9 and 11), and spectral data (clause 9) will be given here.

8.3.2.3 Recovering ics_info()

For single_channel_element()'s ics_info() is always located immediately after the global_gain in the individual_channel_stream(). For a channel_pair_element() there are two possible locations for the ics_info(). If each individual channel in the pair window switch together then the ics_info() is located immediately after common_window in the channel_pair_element() and common_window is set to 1. Otherwise there is an ics_info() immediately after global_gain in each of the two individual_channel_stream() in the channel_pair_element() and common_window is set to 0.

ics_info() carries window information associated with an ICS and thus permits channels in a channel_pair to switch separately if desired. In addition it carries the max_sfb which places an upper limit on the number of ms_used[] and predictor_used[] bits that must be transmitted. If the window_sequence is EIGHT_SHORT_SEQUENCE then scale_factor_grouping is transmitted. If a set of short windows form a group then they share scalefactors as well as intensity stereo positions and have their spectral coefficients interleaved. The first short window is always a new group so no grouping bit is transmitted. Subsequent short windows are in the same group if the associated grouping bit is 1. A new group is started if the associated grouping bit is 0. It is assumed that grouped short windows have similar signal statistics. Hence their spectra are interleaved so as to place correlated coefficients next to each other. The manner of interleaving is indicated in Figure 6. ics_info() also carries the prediction data for the individual channel or channel pair (see clause 13).

8.3.2.4 Recovering Sectioning Data

In the ICS, the information about one long window, or eight short windows, is recovered. The sectioning data is the first field to be decoded, and describes the Huffman codes that apply to the scalefactor bands in the ICS (see clause 9 and 11). The form of the section data is:

sect_cb The codebook for the section

and

sect_len The length of the section.

This length is recovered by reading the bitstream sequentially for a section length, adding the escape value to the total length of the section until a non-escape value is found, which is added to establish the total length of the section. This process is clearly explained in the C-like syntax description. Note that within each group the sections must delineate the scalefactor bands from zero to **max_sfb** so that the first section within each group starts at bands zero and the last section within each group ends at **max_sfb**.

The sectioning data describes the codebook, and then the length of the section using that codebook, starting from the first scalefactor band and continuing until the total number of scalefactor bands is reached.

After this description is provided, all scalefactors and spectral data corresponding to codebook zero are zeroed, and no values corresponding to these scalefactors or spectral data will be transmitted. When scanning for scale-factor data it is important to note that scalefactors for any scalefactor bands whose Huffman codebook is zero will be omitted. Similarly, all spectral data associated with Huffman codebook zero are omitted (see clause 9 and 11).

In addition spectral data associated with the scalefactor bands that have an intensity codebook will not be transmitted, but intensity steering coefficients will be transmitted in place of the scalefactors, as described in subclause 12.2.

8.3.2.5 Scalefactor Data Parsing and Decoding

For each scalefactor band that is not in a section coded with the zero codebook (ZERO_HCB), a scalefactor is transmitted. These will be denoted as 'active' scalefactor bands and the associated scalefactors as active scalefactors. Global gain, the first data element in an ICS, is typically the value of the first active scalefactor. All scalefactors (and steering coefficients) are transmitted using Huffman coded DPCM relative to the previous active scalefactor (see clause 9 and 11). The first active scalefactor is differentially coded relative to the global gain. Note that it is not illegal, merely inefficient, to provide a global_gain that is different from the first active scalefactor and then a non-zero DPCM value for the first scalefactor DPCM value. If any intensity steering coefficients are received interspersed with the DPCM scalefactor elements, they are sent to the intensity stereo module, and are not involved in the DPCM coding of scalefactor values (see subclause 12.2). The value of the first active scalefactor is usually transmitted as the global_gain with the first DPCM scalefactor having a zero value. Once the scalefactors are decoded to their integer values, the actual values are found via a power function (see clause 11).

8.3.2.6 Spectral Data Parsing and Decoding

The spectral data is recovered as the last part of the parsing of an ICS. It consists of all the non-zeroed coefficients remaining in the spectrum or spectra, ordered as described in the ICS_info. For each non-zero, non-intensity codebook, the data are recovered via Huffman decoding in quads or pairs, as indicated in the noiseless coding tool (see clause 9). If the spectral data is associated with an unsigned Huffman codebook, the necessary sign bits follow the Huffman codeword (see subclause 9.3). In the case of the ESCAPE codebook, if any escape value is received, a corresponding escape sequence will appear after that Huffman code. There may be zero, one or two escape sequences for each codeword in the ESCAPE codebook, as indicated by the presence of escape values in that decoded codeword. For each section the Huffman decoding continues until all the spectral values in that section have been decoded. Once all sections have been decoded, the data is multiplied by the decoded scalefactors and deinterleaved if necessary.

8.3.3 Windows and Window Sequences

Quantization and coding is done in the frequency domain. For this purpose, the time signal is mapped into the frequency domain in the encoder. The decoder performs the inverse mapping as described in clause 15. Depending on the signal, the coder may change the time/frequency resolution by using two different windows: LONG_WINDOW and SHORT_WINDOW. To switch between windows, the transition windows LONG_START_WINDOW and LONG_STOP_WINDOW are used. Table 43 lists the windows, specifies the corresponding transform length and shows the shape of the windows schematically. Two transform lengths are used: 1024 (referred to as long transform) and 128 coefficients (referred to as short transform).

Window sequences are composed of windows in a way that a `raw_data_block()` always contains data representing 1024 output samples. The data element **window_sequence** indicates the window sequence that is actually used. Table 44 lists how the window sequences are composed of individual windows. Refer to clause 15 for more detailed information about the transform and the windows.

8.3.4 Scalefactor Bands and Grouping

Many tools of the decoder perform operations on groups of consecutive spectral values called scalefactor bands (abbreviation 'sfb'). The width of the scalefactor bands is built in imitation of the critical bands of the human auditory system. For that reason the number of scalefactor bands in a spectrum and their width depend on the transform length and the sampling frequency. Table 45 to Table 57 list the offset to the beginning of each scalefactor band for the transform lengths 1024 and 128 and the different sampling frequencies, respectively.

To reduce the amount of side information in case of sequences which contain SHORT_WINDOWS, consecutive SHORT_WINDOWS may be grouped (see Figure 4). The information about the grouping is contained in the **scale_factor_grouping** data element. Grouping means that only one set of scalefactors is transmitted for all grouped windows as if there was only one window. The scalefactors are then applied to the corresponding spectral data in all grouped windows. To increase the efficiency of the noiseless coding (see clause 9), the spectral data of a group is transmitted in an interleaved order given in subclause 8.3.5. The interleaving is done on a scalefactor band by scalefactor band basis, so that the spectral data can be grouped to form a virtual scalefactor band to which the common scalefactor can be applied. Within this document the expression 'scalefactor band' (abbreviation 'sfb') denotes these virtual scalefactor bands. If the scalefactor bands of the single windows are referred to, the expression 'scalefactor window band' (abbreviation 'swb') is used. Due to its influence on the scalefactor bands, grouping affects the meaning of `section_data` (see clause 9), the order of spectral data (see subclause 8.3.5), and the total number of scalefactor bands. For a LONG_WINDOW scalefactor bands and scalefactor window bands are identical since there is only one group with only one window.

To reduce the amount of information needed for the transmission of side information specific to each scalefactor band, the data element **max_sfb** is transmitted. Its value is one greater than the highest active scalefactor band in all groups. **max_sfb** has influence on the interpretation of `section_data` (see clause 9), the transmission of scalefactors (see clause 9 and 11), the transmission of predictor data (see clause 13) and the transmission of the `ms_mask` (see subclause 12.1).

Since scalefactor bands are a basic element of the coding algorithm, some help variables and arrays are needed to describe the decoding process in all tools using scalefactor bands. These help variables depend on `sampling_frequency`, **window_sequence**, **scalefactor_grouping** and **max_sfb** and must be built up for each `raw_data_block()`. The pseudo code shown below describes

- how to determine the number of windows in a `window_sequence` *num_windows*
- how to determine the number of window_groups *num_window_groups*
- how to determine the number of windows in each group *window_group_length[g]*
- how to determine the total number of scalefactor window bands *num_swb* for the actual window type
- how to determine *swb_offset[swb]*, the offset of the first coefficient in scalefactor window band *swb* of the window actually used

- how to determine `sect_sfb_offset[g][section]`, the offset of the first coefficient in section `section`. This offset depends on `window_sequence` and `scale_factor_grouping` and is needed to decode the `spectral_data()`.

A long transform window is always described as a window_group containing a single window. Since the number of scalefactor bands and their width depend on the sampling frequency, the affected variables are indexed with `sampling_frequency_index` to select the appropriate table.

```

fs_index = sampling_frequency_index;
switch (window_sequence) {
  case ONLY_LONG_SEQUENCE:
  case LONG_START_SEQUENCE:
  case LONG_STOP_SEQUENCE:
    num_windows = 1;
    num_window_groups = 1;
    window_group_length[num_window_groups-1] = 1;
    num_swb = num_swb_long_window[fs_index];
    /* preparation of sect_sfb_offset for long blocks */
    /* also copy the last value! */
    for (i = 0; i < max_sfb + 1; i++) {
      sect_sfb_offset[0][i] = swb_offset_long_window[fs_index][i];
      swb_offset[i] = swb_offset_long_window[fs_index][i];
    }
    break;
  case EIGHT_SHORT_SEQUENCE:
    num_windows = 8;
    num_window_groups = 1;
    window_group_length[num_window_groups-1] = 1;
    num_swb = num_swb_short_window[fs_index];
    for (i = 0; i < num_swb_short_window[fs_index] + 1; i++)
      swb_offset[i] = swb_offset_short_window[fs_index][i];
    for (i = 0; i < num_windows-1; i++) {
      if(bit_set(scale_factor_grouping,6-i) == 0) {
        num_window_groups += 1;
        window_group_length[num_window_groups-1] = 1;
      }
      else {
        window_group_length[num_window_groups-1] += 1;
      }
    }
    /* preparation of sect_sfb_offset for short blocks */
    for (g = 0; g < num_window_groups; g++) {
      sect_sfb = 0;
      offset = 0;
      for (i = 0; i < max_sfb; i++) {
        width = swb_offset_short_window[fs_index][i+1] -
          swb_offset_short_window[fs_index][i];
        width *= window_group_length[g];
        sect_sfb_offset[g][sect_sfb++] = offset;
        offset += width;
      }
      sect_sfb_offset[g][sect_sfb] = offset;
    }
    break;
  default:
    break;
}

```

8.3.5 Order of Spectral Coefficients in spectral_data()

For ONLY_LONG_SEQUENCE windows (`num_window_groups = 1`, `window_group_length[0] = 1`) the spectral data is in ascending spectral order, as shown in Figure 5.

For the EIGHT_SHORT_SEQUENCE window, the spectral order depends on the grouping in the following manner:

- Groups are ordered sequentially
- Within a group, a scalefactor band consists of the spectral data of all grouped SHORT_WINDOWS for the associated scalefactor window band. To clarify via example, the length of a group is in the range of one to eight SHORT_WINDOWS.
 - If there are eight groups each with length one ($\text{num_window_groups} = 8$, $\text{window_group_length}[0] = 1$), the result is a sequence of eight spectrums, each in ascending spectral order.
 - If there is only one group with length eight ($\text{num_window_group} = 1$, $\text{window_group_length}[0] = 8$), the results is that spectral data of all eight SHORT_WINDOWS is interleaved by scalefactor window bands.
 - Figure 6 shows the spectral ordering for an EIGHT_SHORT_SEQUENCE with grouping of SHORT_WINDOWS according to Figure 4 ($\text{num_window_groups} = 4$).
- Within a scalefactor window band, the coefficients are in ascending spectral order.

8.3.6 Output Word Length

The global gain for each audio channel is scaled such that the integer part of the output of the IMDCT can be used directly as a 16-bit PCM audio output to a digital-to-analog (D/A) converter. This is the default mode of operation and will result in correct audio levels. If the decoder has a D/A converter that has greater than 16-bit resolution then the output of the IMDCT can be scaled up such that the appropriate number of fractional bits are included to form the desired D/A word size. In this case the level of the converter output would be matched to that of a 16-bit D/A, but would have the advantage of greater signal dynamic range and lower converter noise floor. Similarly, shorter D/A word lengths can be accommodated.

8.4 Low Frequency Enhancement Channel (LFE)

8.4.1 General

In order to maintain a regular structure of the decoder, the `lfe_channel_element()` is defined as a standard `individual_channel_stream(0)` element, i.e. equal to a `single_channel_element()`. Thus, decoding can be done using the standard procedure for decoding a `single_channel_element()`.

In order to accommodate a more bitrate and hardware efficient implementation of the LFE decoder, however, several restrictions apply to the options used for the encoding of this element:

- The `window_shape` field is always set to 0, i.e. sine window (see subclause 6.3, Table 15).
- The `window_sequence` field is always set to 0 (ONLY_LONG_SEQUENCE) (see subclause 6.3, Table 15).
- Only the lowest 12 spectral coefficients of any LFE may be non-zero.
- No Temporal Noise Shaping is used, i.e. `tns_data_present` is set to 0 (see subclause 6.3, Table 16).
- No prediction is used, i.e. `predictor_data_present` is set to 0 (see subclause 6.3, Table 15).

The presence of LFE channels depends on the profile used. Refer to clause 7 for detailed information.

8.5 Program Config Element (PCE)

A `program_config_element()` may occur outside the AAC payload e. g. in the `adif_header()`, but also inside the AAC payload as syntactic element in a `raw_data_block()`.

8.5.1 Data Functions

byte_alignment() For PCEs within a `raw_data_block()`, align with respect to the first bit of the `raw_data_block()`. For PCEs within the `adif_header()`, align with respect to the first bit of the header.

8.5.2 Data Elements

profile	The two-bit profile index from Table 31 (Table 25).
sampling_frequency_index	Indicates the sampling rate of the program (and all other programs in this bitstream). See definition in subclause 8.1.2.1 (Table 25).
num_front_channel_elements	The number of audio syntactic elements in the front channels, front center to back center, symmetrically by left and right, or alternating by left and right in the case of single channel elements (Table 25).
num_side_channel_elements	Number of elements to the side as above (Table 25).
num_back_channel_elements	As number of side and front channel elements, for back channels (Table 25).
num_lfe_channel_elements	Number of LFE channel elements associated with this program (Table 25).
num_assoc_data_elements	The number of associated data elements for this program (Table 25).
num_valid_cc_elements	The number of CCE's that can add to the audio data for this program (Table 25).
mono_mixdown_present	One bit, indicating the presence of the mono mixdown element (Table 25).
mono_mixdown_element_number	The number of a specified SCE that is the mono mixdown (Table 25).
stereo_mixdown_present	One bit, indicating that there is a stereo mixdown present (Table 25).
stereo_mixdown_element_number	The number of a specified CPE that is the stereo mixdown element (Table 25).
matrix_mixdown_idx_present	One bit indicating the presence of matrix mixdown information by means of a stereo matrix coefficient index (see Table 39). For all configurations other than the 3/2 format this bit must be zero (Table 25).
matrix_mixdown_idx	Two bit field, specifying the index of the mixdown coefficient to be used in the 5-channel to 2-channel matrix-mixdown. Possible matrix coefficients are listed in Table 39 (Table 25).
pseudo_surround_enable	One bit, indicating the possibility of mixdown for pseudo surround reproduction (Table 25).
front_element_is_cpe	indicates whether a SCE or a CPE is addressed as a front element (Table 25). '0' selects an SCE. '1' selects an CPE. The

	instance of the SCE or CPE addressed is given by <code>front_element_tag_select</code> .
front_element_tag_select	The <code>instance_tag</code> of the SCE/CPE addressed as a front element (Table 25).
side_element_is_cpe	see <code>front_element_is_cpe</code> , but for side elements (Table 25).
side_element_tag_select	see <code>front_element_tag_select</code> , but for side elements (Table 25).
back_element_is_cpe	see <code>front_element_is_cpe</code> , but for back elements (Table 25).
back_element_tag_select	see <code>front_element_tag_select</code> , but for back elements (Table 25).
lfe_element_tag_select	<code>instance_tag</code> of the LFE addressed (Table 25).
assoc_data_element_tag_select	<code>instance_tag</code> of the DSE addressed (Table 25).
valid_cc_element_tag_select	<code>instance_tag</code> of the CCE addressed (Table 25).
cc_element_is_ind_sw	One bit, indicating that the corresponding CCE is an independently switched coupling channel (Table 25).
comment_field_bytes	The length, in bytes, of the following comment field (Table 25).
comment_field_data	The data in the comment field (Table 25).

SCE or CPE elements within the PCE are addressed with two syntax elements. First, an `is_cpe` syntax element selects whether a SCE or CPE is addressed. Second, a `tag_select` syntax element selects the `instance_tag` of a SCE/CPE. LFE, CCE and DSE elements are directly addressed with their `instance_tag`.

8.5.3 Channel configuration

The AAC audio syntax provides three ways to convey the mapping of channels within a set of syntactic elements to physical locations of speakers.

8.5.3.1 Explicit channel mapping using default channel settings

Default channel mappings are defined in Table 42 (values greater than 0).

8.5.3.2 Explicit channel mapping using a `program_config_element()`

Any possible channel configuration can be specified using a `program_config_element()`. There are 16 available PCE's, and each one can specify a distinct program that is present in the raw data stream. All available PCE's within a `raw_data_block()` must come before all other syntactic elements. Programs may or may not share audio syntactic elements, for example, programs could share a `channel_pair_element()` and use distinct coupling channels for voice over in different languages. A given `program_config_element()` contains information pertaining to only one program out of many that may be included in the `raw_data_stream()`. Included in the PCE are "list of front channels", using the rule center outwards, left before right. In this list, a center channel SCE, if any, must come first, and any other SCE's must appear in pairs, constituting an LR pair. If only two SCE's are specified, this signifies one LR stereophonic pair.

After the list of front channels, there is a list of "side channels" consisting of CPE's, or of pairs of SCE's. These are listed in the order of front to back. Again, in the case of a pair of SCE's, the first is a left channel, the second a right channel.

After the list of side channels, a list of back channels is available, listed from outside in. Any SCE's except the last SCE must be paired, and the presence of exactly two SCE's (alone or preceded by a CPE) indicates that the two SCE's are Left and Right Rear center, respectively.

The configuration indicated by the PCE takes effect at the `raw_data_block()` containing the PCE. The number of front, side and back channels as specified in the PCE must be present in that block and all subsequent `raw_data_block()`'s until a `raw_data_block()` containing a new PCE is transmitted.

Other elements are also specified. A list of one or more LFE's is specified for application to this program. A list of one or more CCE's (profile-dependent) is also provided, in order to allow for dialog management as well as different intensity coupling streams for different channels using the same main channels. A list of data streams associated with the program can also associate one or more data streams with a program. The program configuration element also allows for the specification of one monophonic and one stereophonic simulcast mixdown channel for a program. Note that the MPEG-2 Systems standard ISO/IEC 13818-1 supports alternate methods of simulcast.

A PCE element is not intended to allow for rapid program changes. At any time when a given PCE, as selected by its `element_instance_tag`, defines a new (as opposed to repeated) program, the decoder is not obliged to provide audio signal continuity.

8.5.3.3 Implicit channel mapping

If no explicit channel mapping is given, the following methods describe the implicit channel mapping:

1) Any number of SCE's may appear (as long as permitted by other constraints, for example profile). If this number of SCE's is odd, then the first SCE represents the front center channel, and the other SCE's represent L/R pairs of channels, proceeding from center front outwards and back to center rear.

If the number of SCE's is even, then the SCE's are assigned as pairs as center-front L/R, in pairs proceeding out and back from center front toward center back.

2) Any number of CPE's or pairs of SCE's may appear. Each CPE or pair of SCE's represents one L/R pair, proceeding from where the first sets of SCE's left off, pairwise until reaching either center back pair.

3) Any number of SCEs may appear. If this number is even, allocating pairs of SCEs Left/Right, from 2), back to center back. If this number is odd, allocated as L/R pairs, except for the final SCE, which is assigned to center back..

4) Any number of LFEs may appear. No speaker mapping is defined in case of multiple LFEs.

In the case of such implicit channel mapping the number and order of SCEs, CPEs and LFEs and the resulting configuration may not change within the bitstream without sending a `program_config_element()`, i.e. an implicit reconfiguration is not allowed.

Other audio syntactic elements that do not imply additional output speakers, such as coupling `channel_element`, may follow the listed set of syntactic elements. Obviously non-audio syntactic elements may be received in addition and in any order relative to the listed syntactic elements.

8.5.4 Matrix-mixdown Method

8.5.4.1 Description

The matrix-mixdown method applies only for mixing a 3-front/2-back speaker configuration, 5-channel program, down to a stereo or a mono program. It is not applicable to any program with other than the 3/2 configuration.

8.5.4.2 Matrix-mixdown Process

A derived stereo signal can be generated within a matrix-mixdown decoder by use of one of the two following sets of equations.

Set 1:

$$L' = \frac{1}{1 + 1/\sqrt{2} + A} \cdot [L + C/\sqrt{2} + A \cdot L_S]$$

$$R' = \frac{1}{1 + 1/\sqrt{2} + A} \cdot [R + C/\sqrt{2} + A \cdot R_S]$$

Set 2:

$$L' = \frac{1}{1 + 1/\sqrt{2} + 2 \cdot A} \cdot [L + C/\sqrt{2} - A \cdot (L_S + R_S)]$$

$$R' = \frac{1}{1 + 1/\sqrt{2} + 2 \cdot A} \cdot [R + C/\sqrt{2} + A \cdot (L_S + R_S)]$$

Where L, C, R, LS and RS are the source signals, L' and R' are the derived stereo signals and A is the matrix coefficient indicated by matrix_mixdown_idx. LFE channels are omitted from the mixdown.

If pseudo_surround_enable is not set, then only set 1 should be used. If pseudo_surround_enable is set, then either set 1 or set 2 equations can be used, depending on whether the receiver has facilities to invoke some form of surround synthesis.

As further information it should be noted that one can derive a mono signal using the following equation:

$$M = \frac{1}{3 + 2 \cdot A} \cdot [L + C + R + A \cdot (L_S + R_S)]$$

8.5.4.3 Advisory

The matrix-mixdown provision enables a mode of operation which may be beneficial to some operators in some circumstances. However, it is advised that this method should not be used. The psychoacoustic principles on which the audio coding are based are violated by this form of post-processing, and a perceptually faithful reconstruction of the signal cannot be guaranteed. The preferred method is to use the stereo or mono mixdown channels in the AAC syntax to provide stereo or mono programming which is specifically created by conventional studio mixing prior to bitrate reduction.

The stereo and mono mixdown channels additionally enable the content provider to separately optimize the stereo and multichannel program mixes - this is not possible by using the matrix-mixdown method.

It is additionally relevant to note that, due to the algorithms used for the multichannel and stereo mixdown coding, a better combination of quality and bitrate is usually provided by use of the stereo mixdown channels than can be provided by the matrix-mixdown process.

8.5.4.4 Tables

Table 39 — Matrix-mixdown coefficients

matrix_mixdown_idx	A
0	$1/\sqrt{2}$
1	$1/2$
2	$1/(2\sqrt{2})$
3	0

8.6 Data Stream Element (DSE)

8.6.1 Data Functions

byte_alignment() align with respect to the first bit of the raw_data_block().

8.6.2 Data Elements

data_byte_align_flag One bit indicating that a byte alignment is performed within the data stream element (Table 24)

count Initial value for length of data stream (Table 24)

esc_count Incremental value of length of data or padding element (Table 24)

data_stream_byte A data stream byte extracted from bitstream (Table 24)

A data element contains any additional data, e.g. auxiliary information, that is not part of the audio information itself. Any number of data elements with the same element_instance_tag or up to 16 data elements with different element_instance_tags are possible. The decoding process of the data element is described in this clause.

8.6.3 Decoding Process

The first syntactic element to be read is the 1 bit **data_byte_align_flag**. Next is the 8 bit value **count**. It contains the initial byte-length of the data stream. If **count** equals 255, its value is incremented by a second 8 bit value, **esc_count**, this final value represents the number of bytes in the data stream element. If **data_byte_align_flag** is set, a byte alignment is performed. The bytes of the data stream follow.

8.7 Fill Element (FIL)

8.7.1 Data Elements

count Initial value for length of extension_payload() (Table 26).

esc_count Incremental value for length of extension_payload() (Table 26).

8.7.2 Decoding Process

fill_element()'s might be added to allow for several kinds of extension payloads. Any number of fill_element()'s is allowed.

The syntactic element **count** gives the initial value of the length of the fill data. In the same way as for the data element this value is incremented with the value of **esc_count** if **count** equals 15. The resulting number gives the number of **fill_bytes** to be read.

8.8 Extension Payload

8.8.1 General

8.8.1.1 Data Elements

extension_type Four bit field indicating the type of fill element content (Table 26).

8.8.1.2 Decoding Process

Any number of extension_payload()'s are allowed.

The following symbolic abbreviations for values of the extension_type field are defined:

Table 40 — Values of the extension_type data element

Symbol	Value of extension_type	Purpose
EXT_FILL	'0000'	Bitstream filler
EXT_FILL_DATA	'0001'	Bitstream data as filler
EXT_DYNAMIC_RANGE	'1011'	Dynamic range control
EXT_SBR_DATA	'1101'	SBR enhancement
EXT_SBR_DATA_CRC	'1110'	SBR enhancement with CRC
-	all other values	reserved

The 'reserved' values might be used for further extension of the syntax in a compatible way.

8.8.2 Fill data and other bits

8.8.2.1 Data Elements

fill_nibble Four bit field for fill (Table 28).

fill_byte Byte to be discarded by the decoder (Table 28).

other_bits Bits to be discarded by the decoder (Table 28).

8.8.2.2 Decoding Process

Fill data shall be added if the total bits for all audio data together with all additional data is lower than the minimum allowed number of bits in this frame necessary to reach the target bitrate. Under normal conditions fill bits are avoided and free bits are used to fill up the bit reservoir. Fill bits are written only if the bit reservoir is full.

Note that fill_nibble is normatively defined to be '0000' and fill_byte is normatively defined to be '10100101' (to ensure that self-clocked data streams, such as radio modems, can perform reliable clock recovery).

8.8.3 Dynamic Range Control (DRC)

8.8.3.1 Data Elements

pce_tag_present One bit indicating that program element tag is present (Table 29).

pce_instance_tag Tag field that indicates with which program the dynamic range information is associated (Table 29)

drc_tag_reserved_bits	Reserved (Table 29)
excluded_chns_present	One bit indicating that excluded channels are present (Table 29)
drc_bands_present	One bit indicating that DRC multi-band information is present (Table 29)
drc_band_incr	Number of DRC bands greater than 1 having DRC information (Table 29)
drc_bands_reserved_bits	Reserved (Table 29)
drc_band_top[i]	Indicates top of i-th DRC band in units of 4 spectral lines (Table 29). If $drc_band_top[i] = k$, then the index (w.r.t zero) of the highest spectral coefficient that is in the i-th DRC band is $= k*4+3$. In case of an EIGHT_SHORT_SEQUENCE window_sequence the index is interpreted as pointing into the concatenated array of $8*128$ (de-interleaved) frequency points corresponding to the 8 short transforms.
prog_ref_level_present	One bit indicating that reference level is present (Table 29).
prog_ref_level	Reference level. A measure of long-term program audio level for all channels combined (Table 29).
prog_ref_level_reserved_bits	Reserved (Table 29)
dyn_rng_sgn[i]	Dynamic range control sign information. One bit indicating the sign of dyn_rng_ctl (0 if positive, 1 if negative, (Table 29)
dyn_rng_ctl[i]	Dynamic range control magnitude information (Table 29)
exclude_mask[i]	Boolean array indicating the audio channels of a program that are excluded from DRC processing using this DRC information.
additional_excluded_chns[i]	One bit indicating that additional excluded channels are present (Table 30)

8.8.3.2 Decoding Process

The evaluation of potentially available dynamic range control information in the decoder is optional.

prog_ref_level_present indicates that **prog_ref_level** is being transmitted. This permits **prog_ref_level** to be sent as infrequently as desired (e.g. once), although periodic transmission would permit break-in.

prog_ref_level is quantized in 0.25 dB steps using 7 bits, and therefore has a range of approximately 32 dB. It indicates program level relative to full scale (i.e. dB below full scale), and is reconstructed as:

$$level = 32767 \cdot 2^{-prog_ref_level / 24}$$

where „full scale level,, is 32767 ($prog_ref_level$ equal to 0).

pce_tag_present indicates that **pce_instance_tag** is being transmitted. This permits **pce_instance_tag** to be sent as infrequently as desired (e.g. once), although periodic transmission would permit break-in.

pce_instance_tag indicates with which program the dynamic range information is associated. If this is not present then the default program is indicated. Since each AAC bitstream typically has just one program, this would be the most common mode. Each program in a multi-program bitstream would send its dynamic range

information in a distinct `extension_payload()` of the `fill_element()`. In the multiple program case, the `pce_instance_tag` would always have to be signaled.

The `drc_tag_reserved_bits` fill out the optional fields to an integral number of bytes in length.

The `excluded_chns_present` bit indicates that channels that are to be *excluded* from dynamic range processing will be signaled immediately following this bit. The excluded channel mask information must be transmitted in each frame where channels are excluded. The following ordering principles are used to assign the `exclude_mask` to channel outputs:

- If a PCE is present, the `exclude_mask` bits correspond to the audio channels in the SCE, CPE, CCE and LFE syntax elements in the order of their appearance in the PCE. In the case of a CPE, the first transmitted mask bit corresponds to the first channel in the CPE, the second transmitted mask bit to the second channel. In the case of a CCE, a mask bit is transmitted only if the coupling channel is specified to be an independently switched coupling channel.
- If no PCE is present, the `exclude_mask` bits correspond to the audio channels in the SCE, CPE and LFE syntax elements in the order of their appearance in the bitstream, followed by the audio channels in the CCE syntax elements in the order of their appearance in the bitstream. In the case of a CPE, the first transmitted mask bit corresponds to the first channel in the CPE, the second transmitted mask bit to the second channel. In the case of a CCE, a mask bit is transmitted only if the coupling channel is specified to be an independently switched coupling channel.

`drc_band_incr` is the number of bands greater than one if there is multi-band DRC information.

`dyn_rng_ctl` is quantized in 0.25 dB steps using a 7-bit unsigned integer, and therefore, in association with `dyn_rng_sgn`, has a range of +/-31.75 dB. It is interpreted as a gain value that shall be applied to the decoded audio output samples of the current frame.

The range supported by the dynamic range information is summarized in the following table:

Table 41 — Range supported by the DRC information

Field	bits	steps	stepsize, dB	range, dB
<code>prog_ref_level</code>	7	128	0.25	31.75
<code>dyn_rng_sgn</code> and <code>dyn_rng_ctl</code>	1 and 7	+/- 127	0.25	+/- 31.75

The dynamic range control process is applied to the spectral data `spec[i]` of one frame immediately before the synthesis filterbank. In case of an `EIGHT_SHORT_SEQUENCE` window_sequence the index `i` is interpreted as pointing into the concatenated array of 8×128 (de-interleaved) frequency points corresponding to the 8 short transforms.

This following pseudo code is for illustrative purposes only, showing one method for applying one set of dynamic control information to a frame of a target audio channel. The constants `ctrl1` and `ctrl2` are compression constants (typically between 0 and 1, zero meaning no compression) that may optionally be used to scale the dynamic range compression characteristics for levels greater than or less than the program reference level, respectively. The constant `target_level` describes the output level desired by the user, expressed in the same scaling as `prog_ref_level`.

```
bottom = 0;
drc_num_bands = 1;
if (drc_bands_present)
    drc_num_bands += drc_band_incr;
else
    drc_band_top[0] = 1024/4 - 1;
for (bd = 0; bd < drc_num_bands; bd++) {
    top = 4 * (drc_band_top[bd] + 1);
```

```

/* Decode DRC gain factor */
if (dyn_rng_sgn[bd])
    factor = 2^(-ctrl1*dyn_rng_ctl[bd]/24); /* compress */
else
    factor = 2^(ctrl2*dyn_rng_ctl[bd]/24); /* boost */

/* If program reference normalization is done in the digital domain, modify
 * factor to perform normalization.
 * prog_ref_level can alternatively be passed to the system for modification
 * of the level in the analog domain. Analog level modification avoids
problems
 * with reduced DAC SNR (if signal is attenuated) or clipping
 * (if signal is boosted)
 */
factor *= 0.5^((target_level-prog_ref_level)/24);

/* Apply gain factor */
for (i = bottom; i < top; i++)
    spec[i] *= factor;
bottom = top;
}

```

Note the relation between dynamic range control and coupling channels:

- Dependently switched coupling channels are always coupled onto their target channels as spectral coefficients prior to the DRC processing and synthesis filtering of these channels. Therefore a dependently switched coupling channel's signal that couples onto a specific target channel will undergo the DRC processing of that target channel.
- Since independently switched coupling channels couple to their target channels in the time domain, each independently switched coupling channel will undergo DRC processing and subsequent synthesis filtering separate from its target channels. This permits the independently switched coupling channel to have distinct DRC processing if desired.

8.8.3.3 Persistence of DRC Information

At the beginning of a stream, all DRC information for all channels is assumed to be set to its default value: program reference level equal to the decoder's target reference level, one DRC band, with no DRC gain modification for that band. Unless this data is specifically overwritten, this remains in effect.

There are two cases for the persistence of DRC information that has been transmitted:

- The program reference level is per audio program, and persists until a new value is transmitted, at which point the new data overwrites the old and takes effect that frame. (It may be appropriate to send this value periodically to allow bitstream break-in.)
- Other DRC information persists on a per-channel basis. Note that if a channel is excluded via the appropriate **exclude_mask[]** bit, then effectively no information is transmitted for that channel in that call to `dynamic_range_info()`. The excluded channel mask information must be transmitted in each frame where channels are excluded.

The rules for retaining per-channel DRC information are as follows:

- If there is no DRC information in a given frame for a given channel, use the information that was used in the previous frame. (This means that one adjustment can hold for a long time, although it may be appropriate to transmit the DRC information periodically to permit break-in.)
- If any DRC information for this channel appears in the current frame, the following sequence occurs: first, overwrite all per-channel DRC information for that channel with the default values (one DRC band, with no DRC gain modification for that band), then overwrite any per-channel DRC information with the transmitted values.

8.8.4 Bandwidth Extension (SBR)

Fill elements containing an `extension_payload` with an `extension_type` of `EXT_SBR_DATA` or `EXT_SBR_DATA_CRC` are reserved for SBR enhancement data. In this case, the `fill_element` count field must be set equal to the total length in bytes, including the SBR enhancement data plus the `extension_type` field.

`sbr_extension_data()` and the decoding process are defined in ISO/IEC 14496-3.

The SBR fill elements shall be handled according to ISO/IEC 14496-3, subclause 4.5.2.8.2.2 "SBR Extension Payload for the Audio Object Types AAC main, AAC SSR, AAC LC and AAC LTP". The signaling of SBR shall be done implicitly as outlined in ISO/IEC 14496-3, subclause 1.6.5 "Signaling of SBR".

8.9 Tables

Table 42 — Channel Configuration

value	number of speakers	audio syntactic elements, listed in order received	element to speaker mapping
0	-	-	defined in <code>program_config_element()</code> (see subclause 8.5.3.2) or implicitly given (see subclause 8.5.3.3)
1	1	<code>single_channel_element()</code>	center front speaker
2	2	<code>channel_pair_element()</code>	left, right front speakers
3	3	<code>single_channel_element()</code> , <code>channel_pair_element()</code>	center front speaker left, right front speakers
4	4	<code>single_channel_element()</code> , <code>channel_pair_element()</code> , <code>single_channel_element()</code>	center front speaker left, right center front speakers, rear surround
5	5	<code>single_channel_element()</code> , <code>channel_pair_element()</code> , <code>channel_pair_element()</code>	center front speaker left, right front speakers, left surround, right surround rear speakers
6	5+1	<code>single_channel_element()</code> , <code>channel_pair_element()</code> , <code>channel_pair_element()</code> , <code>lfe_element()</code>	center front speaker left, right front speakers, left surround, right surround rear speakers, front low frequency effects speaker
7	7+1	<code>single_channel_element()</code> , <code>channel_pair_element()</code> , <code>channel_pair_element()</code> , <code>channel_pair_element()</code> , <code>lfe_element()</code>	center front speaker left, right center front speakers, left, right outside front speakers, left surround, right surround rear speakers, front low frequency effects speaker

Table 43 — Transform windows (for 48 kHz)



window	num_swb	#coeffs	looks like
LONG_WINDOW	49	1024	
SHORT_WINDOW	14	128	
LONG_START_WINDOW	49	1024	
LONG_STOP_WINDOW	49	1024	

Table 44 — Window Sequences



value	window_sequence	num_windows	looks like
0	ONLY_LONG_SEQUENCE = LONG_WINDOW	1	
1	LONG_START_SEQUENCE = LONG_START_WINDOW	1	
2	EIGHT_SHORT_SEQUENCE = 8 * SHORT_WINDOW	8	
3	LONG_STOP_SEQUENCE = LONG_STOP_WINDOW	1	

Table 45 — Scalefactor bands for
LONG_WINDOW, LONG_START_WINDOW, LONG_STOP_WINDOW at 44.1 kHz and 48 kHz

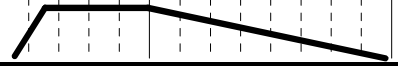
fs [kHz]	44.1, 48
num_swb_long_window	49
swb	swb_offset_long_window
0	0
1	4
2	8
3	12
4	16
5	20
6	24
7	28
8	32
9	36
10	40
11	48
12	56
13	64
14	72
15	80
16	88
17	96
18	108
19	120
20	132
21	144
22	160
23	176
24	196

swb	swb_offset_long_window
25	216
26	240
27	264
28	292
29	320
30	352
31	384
32	416
33	448
34	480
35	512
36	544
37	576
38	608
39	640
40	672
41	704
42	736
43	768
44	800
45	832
46	864
47	896
48	928
	1024

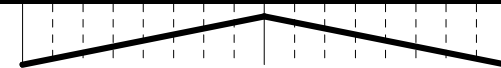
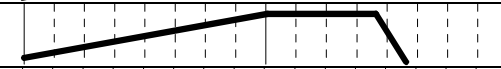
Table 46 — Scalefactor bands for SHORT_WINDOW
at 32 kHz, 44.1 kHz and 48 kHz

fs [kHz]	32, 44.1, 48
num_swb_short_window	14
swb	swb_offset_short_window
0	0
1	4
2	8
3	12
4	16
5	20
6	28
7	36

swb	swb_offset_short_window
8	44
9	56
10	68
11	80
12	96
13	112
	128

Table 47 — Scalefactor bands for
LONG_WINDOW, LONG_START_WINDOW, LONG_STOP_WINDOW
at 32 kHz

fs [kHz]	32
num_swb_long_window	51
swb	swb_offset_long_window
0	0
1	4
2	8
3	12
4	16
5	20
6	24
7	28
8	32
9	36
10	40
11	48
12	56
13	64
14	72
15	80
16	88
17	96
18	108
19	120
20	132
21	144
22	160
23	176
24	196
25	216

swb	swb_offset_long_window
26	240
27	264
28	292
29	320
30	352
31	384
32	416
33	448
34	480
35	512
36	544
37	576
38	608
39	640
40	672
41	704
42	736
43	768
44	800
45	832
46	864
47	896
48	928
49	960
50	992
	1024

Table 48 — Scalefactor bands for
LONG_WINDOW, LONG_START_WINDOW, LONG_STOP_WINDOW at 8 kHz

fs [kHz]	8
num_swb_long_window	40
swb	swb_offset_long_window
0	0
1	12
2	24
3	36
4	48
5	60
6	72
7	84
8	96
9	108
10	120
11	132
12	144
13	156
14	172
15	188
16	204
17	220
18	236
19	252
20	268

swb	swb_offset_long_window
21	288
22	308
23	328
24	348
25	372
26	396
27	420
28	448
29	476
30	508
31	544
32	580
33	620
34	664
35	712
36	764
37	820
38	880
39	944
	1024

Table 49 — Scalefactor bands for SHORT_WINDOW at 8 kHz

fs [kHz]	8
num_swb_short_window	15
swb	swb_offset_short_window
0	0
1	4
2	8
3	12
4	16
5	20
6	24
7	28

swb	swb_offset_short_window
8	36
9	44
10	52
11	60
12	72
13	88
14	108
	128

Table 50 — Scalefactor bands for LONG_WINDOW, LONG_START_WINDOW, LONG_STOP_WINDOW at 11.025 kHz, 12 kHz and 16 kHz

fs [kHz]	11.025, 12, 16
num_swb_long_window	43
swb	swb_offset_long_window
0	0
1	8
2	16
3	24
4	32
5	40
6	48
7	56
8	64
9	72
10	80
11	88
12	100
13	112
14	124
15	136
16	148
17	160
18	172
19	184
20	196
21	212

swb	swb_offset_long_window
22	228
23	244
24	260
25	280
26	300
27	320
28	344
29	368
30	396
31	424
32	456
33	492
34	532
35	572
36	616
37	664
38	716
39	772
40	832
41	896
42	960
	1024

Table 51 — Scalefactor bands for SHORT_WINDOW at 11.025 kHz, 12 kHz and 16 kHz

fs [kHz]	11.025, 12, 16
num_swb_short_window	15
swb	swb_offset_short_window
0	0
1	4
2	8
3	12
4	16
5	20
6	24
7	28

swb	swb_offset_short_window
8	32
9	40
10	48
11	60
12	72
13	88
14	108
	128

Table 52 — Scalefactor bands for
LONG_WINDOW, LONG_START_WINDOW, LONG_STOP_WINDOW at 22.05 kHz and 24 kHz

fs [kHz]	22.05 and 24
num_swb_long_window	47
swb	swb_offset_long_window
0	0
1	4
2	8
3	12
4	16
5	20
6	24
7	28
8	32
9	36
10	40
11	44
12	52
13	60
14	68
15	76
16	84
17	92
18	100
19	108
20	116
21	124
22	136
23	148

swb	swb_offset_long_window
24	160
25	172
26	188
27	204
28	220
29	240
30	260
31	284
32	308
33	336
34	364
35	396
36	432
37	468
38	508
39	552
40	600
41	652
42	704
43	768
44	832
45	896
46	960
	1024

Table 53 — Scalefactor bands for SHORT_WINDOW at 22.05 kHz and 24 kHz

fs [kHz]	22.05 and 24
num_swb_short_window	15
swb	swb_offset_short_window
0	0
1	4
2	8
3	12
4	16
5	20
6	24
7	28

swb	swb_offset_short_window
8	36
9	44
10	52
11	64
12	76
13	92
14	108
	128

Table 54 — Scalefactor bands for LONG_WINDOW, LONG_START_WINDOW, LONG_STOP_WINDOW at 64 kHz

fs [kHz]	64
num_swb_long_window	47
swb	swb_offset_long_window
0	0
1	4
2	8
3	12
4	16
5	20
6	24
7	28
8	32
9	36
10	40
11	44
12	48
13	52
14	56
15	64
16	72
17	80
18	88
19	100
20	112
21	124
22	140
23	156

swb	swb_offset_long_window
24	172
25	192
26	216
27	240
28	268
29	304
30	344
31	384
32	424
33	464
34	504
35	544
36	584
37	624
38	664
39	704
40	744
41	784
42	824
43	864
44	904
45	944
46	984
	1024

Table 55 — Scalefactor bands for SHORT_WINDOW at 64 kHz

fs [kHz]	64
num_swb_short_window	12
swb	swb_offset_short_window
0	0
1	4
2	8
3	12
4	16
5	20
6	24

swb	swb_offset_short_window
7	32
8	40
9	48
10	64
11	92
	128

Table 56 — Scalefactor bands for
LONG_WINDOW, LONG_START_WINDOW, LONG_STOP_WINDOW at 88.2 kHz and 96 kHz

fs [kHz]	88.2 and 96
num_swb_long_window	41
swb	swb_offset_long_window
0	0
1	4
2	8
3	12
4	16
5	20
6	24
7	28
8	32
9	36
10	40
11	44
12	48
13	52
14	56
15	64
16	72
17	80
18	88
19	96
20	108

swb	swb_offset_long_window
21	120
22	132
23	144
24	156
25	172
26	188
27	212
28	240
29	276
30	320
31	384
32	448
33	512
34	576
35	640
36	704
37	768
38	832
39	896
40	960
	1024

Table 57 — Scalefactor bands for SHORT_WINDOW at 88.2 kHz and 96 kHz

fs [kHz]	88.2 and 96
num_swb_short_window	12
swb	swb_offset_short_window
0	0
1	4
2	8
3	12
4	16
5	20
6	24

swb	swb_offset_short_window
7	32
8	40
9	48
10	64
11	92
	128

8.10 Figures

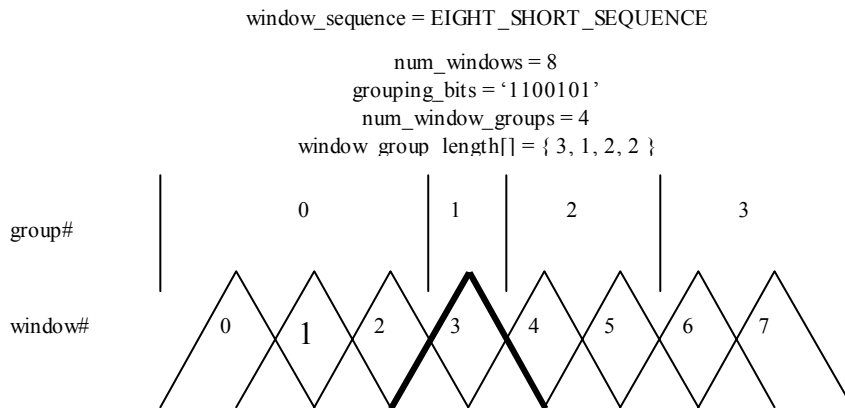

Figure 4 — Example for short window grouping

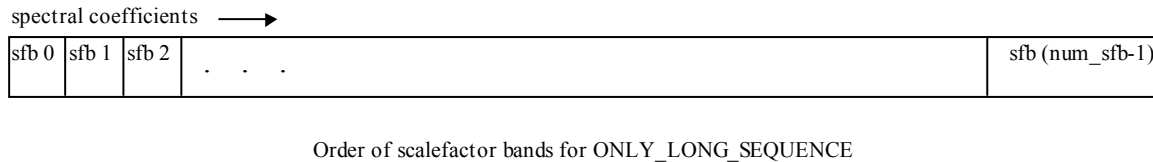

Figure 5 — Spectral order of scalefactor bands in case of ONLY_LONG_SEQUENCE

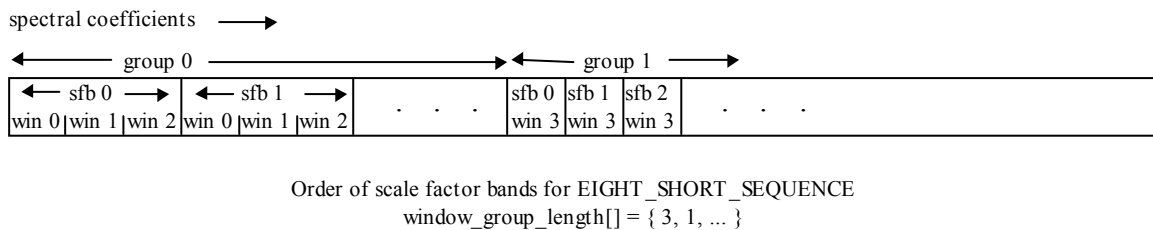

Figure 6 — Spectral order of scalefactor bands in case of EIGHT_SHORT_SEQUENCE

9 Noiseless Coding

9.1 Tool Description

Noiseless coding is used to further reduce the redundancy of the scalefactors and the quantized spectrum of each audio channel.

The global_gain is coded as an 8 bit unsigned integer. The first scalefactor associated with the quantized spectrum is differentially coded relative to the global_gain value and then Huffman coded using the scalefactor codebook. The remaining scalefactors are differentially coded relative to the previous scalefactor and then Huffman coded using the scalefactor codebook.

Noiseless coding of the quantized spectrum relies on two divisions of the spectral coefficients. The first is a division into scalefactor bands that contain a multiple of 4 quantized spectral coefficients. See subclause 8.3.4 and 8.3.5.

The second division, which is dependent on the quantized spectral data, is a division by scalefactor bands to form sections. The significance of a section is that the quantized spectrum within the section is represented using a single Huffman codebook chosen from a set of 11 possible codebooks. The length of a section and its associated Huffman codebook must be transmitted as side information in addition to the section's Huffman coded spectrum. Note that the length of a section is given in scalefactor bands rather than scalefactor window bands (see subclause 8.3.4). In order to maximize the match of the statistics of the quantized spectrum to that of the Huffman codebooks the number of sections is permitted to be as large as the number of scalefactor bands. The maximum size of a section is \max_sfb scalefactor bands.

As indicated in Table 59, spectrum Huffman codebooks can represent signed or unsigned n-tuples of coefficients. For unsigned codebooks, sign bits for every non-zero coefficient in the n-tuple immediately follow the associated codeword.

The noiseless coding has two ways to represent large quantized spectra. One way is to send the escape flag from the escape (ESC) Huffman codebook, which signals that the bits immediately following that codeword plus optional sign bits are an escape sequence that encodes values larger than those represented by the ESC Huffman codebook. A second way is the pulse escape method, in which relatively large-amplitude coefficients can be replaced by coefficients with smaller amplitudes in order to enable the use of Huffman code tables with higher coding efficiency. This replacement is corrected by sending the position of the spectral coefficient and the differences in amplitude as side information. The frequency information is represented by the combination of the scalefactor band number to indicate a base frequency and an offset into that scalefactor band.

9.2 Definitions

9.2.1 Data Elements

sect_cb[g][i]	Spectrum Huffman codebook used for section i in group g (see subclause 6.3, Table 17).
sect_len_incr	Used to compute the length of a section, measures number of scalefactor bands from start of section. The length of sect_len_incr is 3 bits if <code>window_sequence</code> is <code>EIGHT_SHORT_SEQUENCE</code> and 5 bits otherwise (see subclause 6.3, Table 17).
global_gain	Global gain of the quantized spectrum, sent as unsigned integer value (see subclause 6.3, Table 16).
hcod_sf[]	Huffman codeword from the Huffman code Table used for coding of scalefactors (see subclause 6.3, Table 18).
hcod[sect_cb[g][i]][w][x][y][z]	Huffman codeword from codebook sect_cb[g][i] that encodes the next 4-tuple (w, x, y, z) of spectral coefficients, where w, x, y, z are quantized spectral coefficients. Within an n-tuple, w, x, y, z are ordered as described in subclause 8.3.5. so that $x_quant[group][win][sfb][bin] = w$, $x_quant[group][win][sfb][bin+1] = x$, $x_quant[group][win][sfb][bin+2] = y$ and $x_quant[group][win][sfb][bin+3] = z$. N-tuples progress from low to high frequency within the current section (see subclause 6.3, Table 20).
hcod[sect_cb[g][i]][y][z]	Huffman codeword from codebook sect_cb[g][i] that encodes the next 2-tuple (y, z) of spectral coefficients, where y, z are quantized spectral coefficients. Within an n-tuple, y, z are ordered as described in subclause 8.3.5 so that $x_quant[group][win][sfb][bin] = y$ and $x_quant[group][win][sfb][bin+1] = z$. N-tuples progress from low to high frequency within the current section (see subclause 6.3, Table 20).

quad_sign_bits	Sign bits for non-zero coefficients in the spectral 4-tuple. A '1' indicates a negative coefficient, a '0' a positive one. Bits associated with lower frequency coefficients are sent first (see subclause 6.3, Table 20).
pair_sign_bits	Sign bits for non-zero coefficients in the spectral 2-tuple. A '1' indicates a negative coefficient, a '0' a positive one. Bits associated with lower frequency coefficients are sent first (see subclause 6.3, Table 20).
hcod_esc_y	Escape sequence for quantized spectral coefficient y of 2-tuple (y,z) associated with the preceding Huffman codeword (see subclause 6.3, Table 20).
hcod_esc_z	Escape sequence for quantized spectral coefficient z of 2-tuple (y,z) associated with the preceding Huffman codeword (see subclause 6.3, Table 20).
pulse_data_present	1 bit indicating whether the pulse escape is used (1) or not (0) (see subclause 6.3, Table 21). Note that pulse_data_present must be 0 for an EIGHT_SHORT_SEQUENCE.
number_pulse	2 bits indicating how many pulse escapes are used. The number of pulse escapes is from 1 to 4 (see subclause 6.3, Table 21).
pulse_start_sfb	6 bits indicating the index of the lowest scalefactor band where the pulse escape is achieved (see subclause 6.3, Table 21).
pulse_offset[i]	5 bits indicating the offset (see subclause 6.3, Table 21).
pulse_amp[i]	4 bits indicating the unsigned magnitude of the pulse (see subclause 6.3, Table 21).

9.2.2 Help Elements

<i>sect_start[g][i]</i>	Offset to first scalefactor band in section i of group g (see subclause 6.3, Table 17).
<i>sect_end[g][i]</i>	Offset to one higher than last scalefactor band in section i of group g (see subclause 6.3, Table 17).
<i>num_sec[g]</i>	Number of sections in group g (see subclause 6.3, Table 17).
<i>escape_flag</i>	The value of 16 in the ESC Huffman codebook
<i>escape_prefix</i>	The bit sequence of N 1's
<i>escape_separator</i>	One 0 bit
<i>escape_word</i>	An N+4 bit unsigned integer word, msb first
<i>escape_sequence</i>	The sequence of <i>escape_prefix</i> , <i>escape_separator</i> and <i>escape_word</i>
<i>escape_code</i>	$2^{(N+4)} + \text{escape_word}$
<i>x_quant[g][win][sfb][bin]</i>	Huffman decoded value for group g, window win, scalefactor band sfb, coefficient bin
<i>spec[w][k]</i>	De-interleaved spectrum. w ranges from 0 to num_windows-1 and k ranges from 0 to swb_offset[num_swb]-1.

The noiseless coding tool requires these constants (see subclause 6.3, `spectral_data()`).

ZERO_HCB	0
FIRST_PAIR_HCB	5
ESC_HCB	11
QUAD_LEN	4
PAIR_LEN	2
INTENSITY_HCB2	14
INTENSITY_HCB	15
ESC_FLAG	16

9.3 Decoding Process

Four-tuples or 2-tuples of quantized spectral coefficients are Huffman coded and transmitted starting from the lowest-frequency coefficient and progressing to the highest-frequency coefficient. For the case of multiple windows per block (EIGHT_SHORT_SEQUENCE), the grouped and interleaved set of spectral coefficients is treated as a single set of coefficients that progress from low to high. The set of coefficients may need to be de-interleaved after they are decoded (see subclause 8.3.5). Coefficients are stored in the array `x_quant[g][win][sfb][bin]`, and the order of transmission of the Huffman codewords is such that when they are decoded in the order received and stored in the array, *bin* is the most rapidly incrementing index and *g* is the most slowly incrementing index. Within a codeword, for those associated with spectral four-tuples, the order of decoding is *w*, *x*, *y*, *z*; for codewords associated with spectral two-tuples, the order of decoding is *y*, *z*. The set of coefficients is divided into sections and the sectioning information is transmitted starting from the lowest frequency section and progressing to the highest frequency section. The spectral information for sections that are coded with the “zero” codebook is not sent as this spectral information is zero. Similarly, spectral information for sections coded with the “intensity” codebooks is not sent. The spectral information for all scalefactor bands at and above **max_sfb**, for which there is no section data, is zero.

There is a single differential scalefactor codebook which represents a range of values as shown in Table 58. The differential scalefactor codebook is shown in Table A.1. There are eleven Huffman codebooks for the spectral data, as shown in Table 59. The codebooks are shown in Table A.2 through Table A.12. There are three other “codebooks” above and beyond the actual Huffman codebooks, specifically the “zero” codebook, indicating that neither scalefactors nor quantized data will be transmitted, and the “intensity” codebooks indicating that this individual channel is part of a channel pair, and that the data that would normally be scalefactors is instead steering data for intensity stereo. In this case, no quantized spectral data are transmitted. Codebook indices 12 and 13 are reserved.

The spectrum Huffman codebooks encode 2- or 4-tuples of signed or unsigned quantized spectral coefficients, as shown in Table 59. This Table also indicates the largest absolute value (LAV) able to be encoded by each codebook and defines a boolean helper variable array, `unsigned_cb[]`, that is 1 if the codebook is unsigned and 0 if signed.

The result of Huffman decoding each differential scalefactor codeword is the codeword index, listed in the first column of Table A.1. This is translated to the desired differential scalefactor by adding `index_offset` to the index. `index_offset` has a value of -60 , as shown in Table 58. Likewise, the result of Huffman decoding each spectrum *n*-tuple is the codeword index, listed in the first column of Table A.2 through Table A.12. This index is translated to the *n*-tuple spectral values as specified in the following pseudo C-code:

`unsigned` = Boolean value `unsigned_cb[i]`, listed in second column of Table 59.

`dim` = Dimension of codebook, listed in the third column of Table 59.

`lav` = LAV, listed in the fourth column of Table 59.

idx = codeword index

```

if (unsigned) {
    mod = lav + 1;
    off = 0;
}
else {
    mod = 2*lav + 1;
    off = lav;
}

if (dim == 4) {
    w = INT(idx/(mod*mod*mod)) - off;
    idx -= (w+off)*(mod*mod*mod)
    x = INT(idx/(mod*mod)) - off;
    idx -= (x+off)*(mod*mod)
    y = INT(idx/mod) - off;
    idx -= (y+off)*mod
    z = idx - off;
}
else {
    y = INT(idx/mod) - off;
    idx -= (y+off)*mod
    z = idx - off;
}

```

If the Huffman codebook represents signed values, the decoding of the quantized spectral n-tuple is complete after Huffman decoding and translation of codeword index to quantized spectral coefficients. If the codebook represents unsigned values then the sign bits associated with non-zero coefficients immediately follow the Huffman codeword, with a '1' indicating a negative coefficient and a '0' indicating a positive one. For example, if a Huffman codeword from codebook 7

hcod[7][y][z]

has been parsed, then immediately following this in the bitstream is

pair_sign_bits

which is a variable length field of 0 to 2 bits. It can be parsed directly from the bitstream as

```

if (y != 0)
    if (one_sign_bit == 1)
        y = -y;
if (z != 0)
    if (one_sign_bit == 1)
        z = -z;

```

where one_sign_bit is the next bit in the bitstream and pair_sign_bits is the concatenation of the one_sign_bit fields.

The ESC codebook is a special case. It represents values from 0 to 16 inclusive, but values from 0 to 15 encode actual data values, and the value 16 is an *escape_flag* that signals the presence of **hcod_esc_y** or **hcod_esc_z**, either of which will be denoted as an *escape_sequence*. This *escape_sequence* permits quantized spectral elements of LAV>15 to be encoded. It consists of an *escape_prefix* of N 1's, followed by an *escape_separator* of one zero, followed by an *escape_word* of N+4 bits representing an unsigned integer value. The *escape_sequence* has a decoded value of $2^{N+4} + \text{escape_word}$. The desired quantized spectral coefficient is then the sign indicated by the pair_sign_bits applied to the value of the *escape_sequence*. In other words, an *escape_sequence* of 00000 would decode as 16, an *escape_sequence* of 01111 as 31, an *escape_sequence* of 1000000 as 32, one of 1011111 as 63, and so on. Note that restrictions in subclause 10.3 dictate that the length of the *escape_sequence* is always less than 22 bits. For escape Huffman codewords the ordering of data elements is Huffman codeword followed by 0 to 2 sign bits followed by 0 to 2 escape sequences.

When **pulse_data_present** is 1 (the pulse escape is used), one or several quantized coefficients have been replaced by coefficients with smaller amplitudes in the encoder. The number of coefficients replaced is indicated by **number_pulse**. In reconstructing the quantized spectral coefficients x_{quant} this replacement is compensated by adding **pulse_amp** to or subtracting **pulse_amp** from the previously decoded coefficients whose frequency indices are indicated by **pulse_start_sfb** and **pulse_offset**. Note that the pulse escape method is illegal for a block whose **window_sequence** is EIGHT_SHORT_SEQUENCE. The decoding process is specified in the following pseudo-C code:

```

if (pulse_data_present) {
    g = 0;
    win = 0;
    k = swb_offset[pulse_start_sfb];
    for (j = 0; j < number_pulse+1; j++) {
        k += pulse_offset[j];

        /* translate_pulse_parameters(); */
        for (sfb = pulse_start_sfb; sfb < num_swb; sfb++) {
            if (k < swb_offset[sfb+1]) {
                bin = k - swb_offset[sfb] ;
                break;
            }
        }

        /* restore coefficients */
        if (x_quant[g][win][sfb][bin] > 0)
            x_quant[g][win][sfb][bin] += pulse_amp[j];
        else
            x_quant[g][win][sfb][bin] -= pulse_amp[j];
    }
}

```

Several decoder tools (TNS, filterbank) access the spectral coefficients in a non-interleaved fashion, i.e. all spectral coefficients are ordered according to window number and frequency within a window. This is indicated by using the notation $spec[w][k]$ rather than $x_{quant}[g][w][sfb][bin]$.

The following pseudo C-code indicates the correspondence between the four-dimensional, or interleaved, structure of array $x_{quant}[][][][]$ and the two-dimensional, or de-interleaved, structure of array $spec[][]$. In the latter array the first index increments over the individual windows in the window sequence, and the second index increments over the spectral coefficients that correspond to each window, where the coefficients progress linearly from low to high frequency.

```

quant_to_spec() {
    k = 0;
    for (g = 0; g < num_window_groups; g++) {
        j = 0;
        for (sfb = 0; sfb < num_swb; sfb++) {
            width = swb_offset[sfb+1] - swb_offset[sfb];
            for (win = 0; win < window_group_length[g]; win++) {
                for (bin = 0; bin < width; bin++) {
                    spec[win+k][bin+j] = x_quant[g][win][sfb][bin] ;
                }
            }
            j += width;
        }
        k += window_group_length[g];
    }
}

```

9.4 Tables

Table 58 — Scalefactor Huffman codebook parameters

Codebook Number	Dimension of Codebook	index_offset	Range of values	Codebook listed in
0	1	-60	-60 to +60	Table A.1

Table 59 — Spectrum Huffman codebooks parameters

Codebook Number, i	unsigned_cb[i]	Dimension of Codebook	LAV for codebook	Codebook listed in
0	-	-	0	-
1	0	4	1	Table A.2
2	0	4	1	Table A.3
3	1	4	2	Table A.4
4	1	4	2	Table A.5
5	0	2	4	Table A.6
6	0	2	4	Table A.7
7	1	2	7	Table A.8
8	1	2	7	Table A.9
9	1	2	12	Table A.10
10	1	2	12	Table A.11
11	1	2	(16) ESC	Table A.12
12	-	-	(reserved)	-
13	-	-	(reserved)	-
14	-	-	intensity out-of-phase	-
15	-	-	intensity in-phase	-

10 Quantization

10.1 Tool Description

For quantization of the spectral coefficients in the encoder a non uniform quantizer is used. Therefore the decoder must perform the inverse non uniform quantization after the Huffman decoding of the scalefactors (see clause 9 and 11) and spectral data (see clause 9).

10.2 Definitions

10.2.1 Help Elements

$x_quant[g][win][sfb][bin]$ quantized spectral coefficient for group g , window win , scalefactor band sfb , coefficient bin .

$x_invquant[g][win][sfb][bin]$ spectral coefficient for group g , window win , scalefactor band sfb , coefficient bin after inverse quantization.

10.3 Decoding Process

The inverse quantization is described by the following formula:

$$x_invquant = Sign(x_quant) \cdot |x_quant|^{\frac{4}{3}} \forall k$$

The maximum allowed absolute amplitude for x_{quant} is 8191. The inverse quantization is applied as follows:

```

for (g = 0; g < num_window_groups; g++) {
  for (sfb = 0; sfb < max_sfb; sfb++) {
    width = (swb_offset [sfb+1] - swb_offset [sfb]);
    for (win = 0; win < window_group_len[g]; win++) {
      for (bin = 0; bin < width; bin++) {
        x_invquant [g] [win] [sfb] [bin] = sign(x_quant [g] [win] [sfb] [bin]) *
                                           abs(x_quant [g] [win] [sfb] [bin]) ^ (4/3);
      }
    }
  }
}

```

11 Scalefactors

11.1 Tool Description

The basic method to adjust the quantization noise in the frequency domain is the noise shaping using scalefactors. For this purpose the spectrum is divided in several groups of spectral coefficients called scalefactor bands which share one scalefactor (see subclause 8.3.4). A scalefactor represents a gain value which is used to change the amplitude of all spectral coefficients in that scalefactor band. This mechanism is used to change the allocation of the quantization noise in the spectral domain generated by the non uniform quantizer.

For window_sequences which contain SHORT_WINDOWs grouping can be applied, i.e. a specified number of consecutive SHORT_WINDOWs may have only one set of scalefactors. Each scalefactor is then applied to a group of scalefactor bands corresponding in frequency (see subclause 8.3.4).

In this tool the scalefactors are applied to the inverse quantized coefficients to reconstruct the spectral values.

11.2 Definitions

11.2.1 Data Functions

scale_factor_data() Part of bitstream which contains the differential coded scalefactors (see Table 18)

11.2.2 Data Elements

global_gain An 8-bit unsigned integer value representing the value of the first scalefactor. It is also the start value for the following differential coded scalefactors (see Table 16)

hcod_sf[] Huffman codeword from the Huffman code Table used for coding of scalefactors, see Table 18 and subclause 9.2

11.2.3 Help Elements

dpcm_sf[g][sfb] Differential coded scalefactor of group g, scalefactor band sfb.

x_rescal[] Rescaled spectral coefficients

sf[g][sfb] Array for scalefactors of each group

get_scale_factor_gain() Function that returns the gain value corresponding to a scalefactor

11.3 Decoding Process

11.3.1 Scalefactor Bands

Scalefactors are used to shape the quantization noise in the spectral domain. For this purpose, the spectrum is divided into several scalefactor bands (see subclause 8.3.4). Each scalefactor band has a scalefactor, which represents a certain gain value which has to be applied to all spectral coefficients in this scalefactor band. In case of EIGHT_SHORT_SEQUENCE a scalefactor band may contain multiple scalefactor window bands of consecutive SHORT_WINDOWS (see subclause 8.3.4 and 8.3.5).

11.3.2 Decoding of Scalefactors

For all scalefactors the difference to the preceding value is coded using the Huffman code book given in Table A.1. See clause 9 for a detailed description of the Huffman decoding process. The start value is given explicitly as a 8 bit PCM in the data element **global_gain**. A scalefactor is not transmitted for scalefactor bands which are coded with the Huffman codebook ZERO_HCB. If the Huffman codebook for a scalefactor band is coded with INTENSITY_HCB or INTENSITY_HCB2, the scalefactor is used for intensity stereo (see clause 9 and subclause 12.2). In that case a normal scalefactor does not exist (but is initialized to zero to have a valid entry in the array).

The following pseudo code describes how to decode the scalefactors $sf[g][sfb]$:

```

last_sf = global_gain;
for (g = 0; g < num_window_groups; g++) {
  for (sfb = 0; sfb < max_sfb; sfb++) {
    if (sfb_cb[g][sfb] != ZERO_HCB && sfb_cb[g][sfb] != INTENSITY_HCB
        && sfb_cb[g][sfb] != INTENSITY_HCB2) {
      dpcm_sf = decode_huffman() - index_offset; /* see clause 9*/
      sf[g][sfb] = dpcm_sf + last_sf;
      last_sf = sf[g][sfb];
    }
    else {
      sf[g][sfb] = 0;
    }
  }
}

```

Note that scalefactors, $sf[g][sfb]$, must be within the range of zero to 255, both inclusive.

11.3.3 Applying Scalefactors

The spectral coefficients of all scalefactor bands which correspond to a scalefactor have to be rescaled according to their scalefactor. In case of a window sequence that contains groups of short windows all coefficients in grouped scalefactor window bands have to be scaled using the same scalefactor.

In case of window_sequences with only one window, the scalefactor bands and their corresponding coefficients are in spectral ascending order. In case of EIGHT_SHORT_SEQUENCE and grouping the spectral coefficients of grouped short windows are interleaved by scalefactor window bands. See subclause 8.3.5 for more detailed information.

The rescaling operation is done according to the following pseudo code:

```

for (g = 0; g < num_window_groups; g++) {
  for (sfb = 0; sfb < max_sfb; sfb++) {
    width = (swb_offset[sfb+1] - swb_offset[sfb]);
    for (win = 0; win < window_group_len[g]; win++) {
      gain = get_scale_factor_gain(sf[g][sfb]);
      for (k = 0; k < width; k++) {
        x_rescal[g][window][sfb][k] =
          x_invquant[g][window][sfb][k] * gain;
      }
    }
  }
}

```

```

}
}
}

```

The function `get_scale_factor_gain(sf[g][sfb])` returns the gain factor that corresponds to a scalefactor. The return value follows the equation:

$$gain = 2^{0.25 \cdot (sf[g][sfb] - SF_OFFSET)}$$

The constant `SF_OFFSET` must be set to 100.

The following pseudo code describes this operation:

```

get_scale_factor_gain( sf[g][sfb] ) {
    SF_OFFSET = 100;
    gain = 2^(0.25 * ( sf[g][sfb] - SF_OFFSET ));
    return (gain);
}

```

12 Joint Coding

12.1 M/S Stereo

12.1.1 Tool Description

The M/S joint channel coding operates on channel pairs. Channels are most often paired such that they have symmetric presentation relative to the listener, such as left/right or left surround/right surround. The first channel in the pair is denoted “left” and the second “right.” On a per-spectral-coefficient basis, the vector formed by the left and right channel signals is reconstructed or de-matrixed by either the identity matrix

$$\begin{bmatrix} l \\ r \end{bmatrix} = \begin{bmatrix} 1 & 0 \\ 0 & 1 \end{bmatrix} \begin{bmatrix} l \\ r \end{bmatrix}$$

or the inverse M/S matrix

$$\begin{bmatrix} l \\ r \end{bmatrix} = \begin{bmatrix} 1 & 1 \\ 1 & -1 \end{bmatrix} \begin{bmatrix} m \\ s \end{bmatrix}$$

The decision on which matrix to use is done on a scalefactor band by scalefactor band basis as indicated by the `ms_used` flags. M/S joint channel coding can only be used if `common_window` is ‘1’ (see subclause 8.3.1).

12.1.2 Definitions

12.1.2.1 Data Elements

ms_mask_present

This two bit field indicates that the MS mask is

00 All zeros

01 A mask of `max_sfb` bands of `ms_used` follows this field

10 All ones

11 Reserved

(see subclause 6.3, Table 14)

ms_used[g][sfb]

One-bit flag per scalefactor band indicating that M/S coding is being used in windowgroup `g` and scalefactor band `sfb` (see subclause 6.3, Table 14).

12.1.2.2 Help Elements

<i>l_spec</i> []	Array containing the left channel spectrum of the respective channel pair.
<i>r_spec</i> []	Array containing the right channel spectrum of the respective channel pair.
<i>is_intensity</i> (<i>g,sfb</i>)	Function returning the intensity status, defined in 12.2.3

12.1.3 Decoding Process

Reconstruct the spectral coefficients of the first (“left”) and second (“right”) channel as specified by the **mask_present** and the **ms_used**[][] flags as follows:

```

if (mask_present >= 1) {
  for (g = 0; g < num_window_groups; g++) {
    for (b = 0; b < window_group_length[g]; b++) {
      for (sfb = 0; sfb < max_sfb; sfb++) {
        if ((ms_used[g][sfb] | mask_present == 2) && !is_intensity(g,sfb)) {
          for (i = 0; i < swb_offset[sfb+1]-swb_offset[sfb]; i++) {
            tmp = l_spec[g][b][sfb][i] - r_spec[g][b][sfb][i];
            l_spec[g][b][sfb][i] = l_spec[g][b][sfb][i] + r_spec[g][b][sfb][i];
            r_spec[g][b][sfb][i] = tmp;
          }
        }
      }
    }
  }
}

```

Please note that **ms_used**[][] is also used in the context of intensity stereo coding. If intensity stereo coding is on for a particular scalefactor band, no M/S stereo decoding is carried out.

12.2 Intensity Stereo

12.2.1 Tool Description

This tool is used to implement joint intensity stereo coding between both channels of a channel pair. Thus, both channel outputs are derived from a single set of spectral coefficients after the inverse quantization process. This is done selectively on a scalefactor band basis when intensity stereo is flagged as active.

12.2.2 Definitions

12.2.2.1 Data Elements

<i>hcod_sf</i> []	Huffman codeword from the Huffman code Table used for coding of scalefactors (see subclause 9.2)
-------------------	--

12.2.2.2 Help Elements

<i>dpcm_is_position</i> [][]	Differentially encoded intensity stereo position
<i>is_position</i> [group][sfb]	Intensity stereo position for each group and scalefactor band
<i>l_spec</i> []	Array containing the left channel spectrum of the respective channel pair
<i>r_spec</i> []	Array containing the right channel spectrum of the respective channel pair

12.2.3 Decoding Process

The use of intensity stereo coding is signaled by the use of the pseudo codebooks INTENSITY_HCB and INTENSITY_HCB2 (15 and 14) only in the right channel of a channel_pair_element() having a common ics_info() (**common_window** == 1). INTENSITY_HCB and INTENSITY_HCB2 signal in-phase and out-of-phase intensity stereo coding, respectively.

In addition, the phase relationship of the intensity stereo coding can be reversed by means of the ms_used field: Because M/S stereo coding and intensity stereo coding are mutually exclusive for a particular scalefactor band and group, the primary phase relationship indicated by the Huffman code tables is changed from in-phase to out-of-phase or vice versa if the corresponding ms_used bit is set for the respective band.

The directional information for the intensity stereo decoding is represented by an "intensity stereo position" value indicating the relation between left and right channel scaling. If intensity stereo coding is active for a particular group and scalefactor band, an intensity stereo position value is transmitted instead of the scalefactor of the right channel.

Intensity positions are coded just like scalefactors, i.e. by Huffman coding of differential values with two differences:

- there is no first value that is sent as PCM. Instead, the differential decoding is started assuming the last intensity stereo position value to be zero.
- Differential decoding is done separately between scalefactors and intensity stereo positions. In other words, the scalefactor decoder ignores interposed intensity stereo position values and vice versa (see subclause 11.3.2)

The same codebook is used for coding intensity stereo positions as for scalefactors.

Two pseudo functions are defined for use in intensity stereo decoding:

```
function is_intensity(group, sfb) {
+1  for window groups / scalefactor bands with right channel codebook
    sfb_cb[group][sfb] == INTENSITY_HCB
-1  for window groups / scalefactor bands with right channel codebook
    sfb_cb[group][sfb] == INTENSITY_HCB2
  0  otherwise
}

function invert_intensity(group, sfb) {
  1-2*ms_used[group][sfb]  if (ms_mask_present == 1)
+1  otherwise
}
```

The intensity stereo decoding for one channel pair is defined by the following pseudo code:

```
p = 0;
for (g = 0; g < num_window_groups; g++) {

  /* Decode intensity positions for this group */
  for (sfb = 0; sfb < max_sfb; sfb++)
    if (is_intensity(g, sfb))
      is_position[g][sfb] = p += dpcm_is_position[g][sfb];

  /* Do intensity stereo decoding */
  for (b = 0; b < window_group_length[g]; b++) {
    for (sfb = 0; sfb < max_sfb; sfb++) {
      if (is_intensity(g, sfb)) {

        scale = is_intensity(g, sfb) * invert_intensity(g, sfb) *
          0.5^(0.25*is_position[g][sfb]);
        /* Scale from left to right channel, do not touch left channel */
        for (i = 0; i < swb_offset[sfb+1]-swb_offset[sfb]; i++)
```

```

        r_spec[g][b][sfb][i] = scale * l_spec[g][b][sfb][i];
    }
}
}
}

```

12.2.4 Integration with Intra Channel Prediction Tool

For scalefactor bands coded in intensity stereo the corresponding predictors in the right channel are switched to "off" thus effectively overriding the status specified by the prediction_used mask. The update of these predictors is done by feeding the intensity stereo decoded spectral values of the right channel as the "last quantized value" $x_{rec}(n-1)$. These values result from the scaling process from left to right channel as described in the pseudo code.

12.3 Coupling Channel

12.3.1 Tool Description

Coupling channel elements provide two functionalities: First, coupling channels may be used to implement generalized intensity stereo coding where channel spectra can be shared across channel boundaries. Second, coupling channels may be used to dynamically perform a downmix of one sound object into the stereo image.

Note that this tool includes certain profile dependent parameters (see subclause 7.1).

12.3.2 Definitions

12.3.2.1 Data Elements

ind_sw_cce_flag	One bit indicating whether the coupled target syntax element is an independently switched (1) or a dependently switched (0) CCE (see subclause 6.3, Table 22).
num_coupled_elements	Number of coupled target channels is equal to num_coupled_elements+1. The minimum value is 0 indicating 1 coupled target channel (see subclause 6.3, Table 22).
cc_target_is_cpe	One bit indicating if the coupled target syntax element is a CPE (1) or a SCE (0) (see subclause 6.3, Table 22).
cc_target_tag_select	Four bit field specifying the element_instance_tag of the coupled target syntax element (see subclause 6.3, Table 22).
cc_l	One bit indicating that a list of gain_element values is applied to the left channel of a channel pair (see subclause 6.3, Table 22).
cc_r	One bit indicating that a list of gain_element values is applied to the right channel of a channel pair (see subclause 6.3, Table 22).
cc_domain	One bit indicating whether the coupling is performed before (0) or after (1) the TNS decoding of the coupled target channels (see subclause 6.3, Table 22).

gain_element_sign	One bit indicating if the transmitted gain_element values contain information about in-phase / out-of-phase coupling (1) or not (0) (see subclause 6.3, Table 22).
gain_element_scale	Determines the amplitude resolution cc_scale of the scaling operation according to Table 61 (see subclause 6.3, Table 22).
common_gain_element_present[c]	One bit indicating whether Huffman coded common_gain_element values are transmitted (1) or whether Huffman coded differential gain_elements are sent (0) (see subclause 6.3, Table 22).

12.3.2.2 Help Elements

<i>dpcm_gain_element[][]</i>	Differentially encoded gain element.
<i>gain_element[group][sfb]</i>	Gain element for each group and scalefactor band.
<i>common_gain_element[]</i>	Gain element that is used for all window groups and scalefactor bands of one coupling target channel.
<i>spectrum_m(idx, domain)</i>	Pointer to the spectral data associated with the single_channel_element() with index idx. Depending on the value of "domain", the spectral coefficients before (0) or after (1) TNS decoding are pointed to.
<i>spectrum_l(idx, domain)</i>	Pointer to the spectral data associated with the left channel of the channel_pair_element() with index idx. Depending on the value of "domain", the spectral coefficients before (0) or after (1) TNS decoding are pointed to.
<i>spectrum_r(idx, domain)</i>	Pointer to the spectral data associated with the right channel of the channel_pair_element() with index idx. Depending on the value of "domain", the spectral coefficients before (0) or after (1) TNS decoding are pointed to.

12.3.3 Decoding Process

The coupling channel is based on an embedded single_channel_element() which is combined with some dedicated fields to accommodate its special purpose.

The coupled target syntax elements (SCEs or CPEs) are addressed using two syntax elements. First, the cc_target_is_cpe field selects whether a SCE or CPE is addressed. Second, a cc_target_tag_select field selects the instance_tag of the SCE/CPE.

The scaling operation involved in channel coupling is defined by gain_element values which describe the applicable gain factor and sign. In accordance with the coding procedures for scalefactors and intensity stereo positions, gain_element values are differentially encoded using the Huffman Table for scalefactors. Similarly, the decoded gain factors for coupling relate to window groups of spectral coefficients.

Independently switched CCEs vs. dependently switched CCEs

There are two kinds of CCEs. They are "independently switched" and "dependently switched" CCEs. An independently switched CCE is a CCE in which the window state (i.e. window_sequence and window_shape) of the CCE does not have to match that of any of the SCE or CPE channels that the CCE is coupled onto (target channels). This has several important implications:

- First, it is required that an independently switched CCE must only use the common_gain element, not a list of gain_elements.

- Second, the independently switched CCE must be decoded all the way to the time domain (i.e. including the synthesis filterbank) before it is scaled and added onto the various SCE and CPE channels that it is coupled to in the case that window state does not match.

A dependently switched CCE, on the other hand, must have a window state that matches all of the target SCE and CPE channels that it is coupled onto as determined by the list of cc_l and cc_r elements. In this case, the CCE only needs to be decoded as far as the frequency domain and then scaled as directed by the gain list before it is added to the target SCE or CPE channels.

The following pseudo code in function decode_coupling_channel() defines the decoding operation for a dependently switched coupling channel element. First the spectral coefficients of the embedded single_channel_element() are decoded into an internal buffer. Since the gain elements for the first coupled target (list_index == 0) are not transmitted, all gain_element values associated with this target are assumed to be 0, i.e. the coupling channel is added to the coupled target channel in its natural scaling. Otherwise the spectral coefficients are scaled and added to the coefficients of the coupled target channels using the appropriate list of gain_element values.

An independently switched CCE is decoded like a dependently switched CCE having only common_gain_element's. However, the resulting scaled spectrum is transformed back into its time representation and then coupled in the time domain.

Please note that the gain_element lists may be shared between the left and the right channel of a target channel pair element. This is signalled by both cc_l and cc_r being zero as indicated in the Table below:

Table 60 — Sharing of gain_element lists

cc_l, cc_r	shared gain list present	left gain list present	right gain list present
0, 0	yes	no	no
0, 1	no	no	yes
1, 0	no	yes	no
1, 1	no	yes	yes

```

decode_coupling_channel()
{
- decode spectral coefficients of embedded single_channel_element
  into buffer "cc_spectrum[]".

/* Couple spectral coefficients onto target channels */
list_index = 0;
for (c = 0; c < num_coupled_elements+1; c++) {
  if (!cc_target_is_cpe[c]) {
    couple_channel(cc_spectrum,
                  spectrum_m(cc_target_tag_select[c],
                            cc_domain), list_index++);
  }
  if (cc_target_is_cpe[c]) {
    if (!cc_l[c] && !cc_r[c]) {
      couple_channel(cc_spectrum,
                    spectrum_l(cc_target_tag_select[c],
                              cc_domain), list_index);
      couple_channel(cc_spectrum,
                    spectrum_r(cc_target_tag_select[c],
                              cc_domain), list_index++);
    }
    if (cc_l[c]) {
      couple_channel(cc_spectrum,
                    spectrum_l(cc_target_tag_select[c],
                              cc_domain), list_index++);
    }
  }
}
}

```

```

        if (cc_r[c]) {
            couple_channel(cc_spectrum,
                          spectrum_r(cc_target_tag_select[c],
                                      cc_domain), list_index++);
        }
    }
}

couple_channel(source_spectrum[], dest_spectrum[], gain_list_index)
{
    idx = gain_list_index;
    a = 0;
    cc_scale = cc_scale_table[gain_element_scale];
    for (g = 0; g < num_window_groups; g++) {

        /* Decode coupling gain elements for this group */
        if (common_gain_element_present[idx]) {

            for (sfb = 0; sfb < max_sfb; sfb++) {
                cc_sign[idx][g][sfb] = 1;
                gain_element[idx][g][sfb] = common_gain_element[idx];
            }
        }
        else {
            for (sfb = 0; sfb < max_sfb; sfb++) {
                if (sfb_cb[g][sfb] == ZERO_HCB)
                    continue;

                if (gain_element_sign) {
                    cc_sign[idx][g][sfb] = 1 - 2*(dpcm_gain_element[idx][g][sfb] & 0x1);
                    gain_element[idx][g][sfb] = a += (dpcm_gain_element[idx][g][sfb] >>
1);
                }
                else {
                    cc_sign[idx][g][sfb] = 1;
                    gain_element[idx][g][sfb] = a += dpcm_gain_element[idx][g][sfb];
                }
            }
        }

        /* Do coupling onto target channels */
        for (b = 0; b < window_group_length[b]; b++) {
            for (sfb = 0; sfb < max_sfb; sfb++) {

                if (sfb_cb[g][sfb] != ZERO_HCB) {
                    cc_gain[idx][g][sfb] = cc_sign[idx][g][sfb] *
cc_scale^gain_element[idx][g][sfb];
                    for (i = 0; i < swb_offset[sfb+1] - swb_offset[sfb]; i++)
                        dest_spectrum[g][b][sfb][i] += cc_gain[idx][g][sfb] *
source_spectrum[g][b][sfb][i];
                }
            }
        }
    }
}

```

Note: The array sfb_cb represents the codebook data respect to the CCE's embedded single_channel_element() (not the coupled target channel).

12.3.4 Tables

Table 61 — Scaling resolution for channel coupling (cc_scale_table)

Value of "gain_element_scale"	Amplitude Resolution "cc_scale"	Stepsize [dB]
0	$2^{(1/8)}$	0.75
1	$2^{(1/4)}$	1.50
2	$2^{(1/2)}$	3.00
3	2^1	6.00

13 Prediction

13.1 Tool Description

Prediction is used for an improved redundancy reduction and is especially effective in case of more or less stationary parts of a signal which belong to the most demanding parts in terms of required bitrate. Prediction can be applied to every channel using an intra channel (or mono) predictor which exploits the auto-correlation between the spectral components of consecutive frames. Because a window_sequence of type EIGHT_SHORT_SEQUENCE indicates signal changes, i.e. non-stationary signal characteristics, prediction is only used if window_sequence is of type ONLY_LONG_SEQUENCE, LONG_START_SEQUENCE or LONG_STOP_SEQUENCE. The use of the prediction tool is profile dependent. See clause 7 for detailed information.

For each channel prediction is applied to the spectral components resulting from the spectral decomposition of the filterbank. For each spectral component up to limit specified by PRED_SFB_MAX, there is one corresponding predictor resulting in a bank of predictors, where each predictor exploits the auto-correlation between the spectral component values of consecutive frames.

The overall coding structure using a filterbank with high spectral resolution implies the use of backward adaptive predictors to achieve high coding efficiency. In this case, the predictor coefficients are calculated from preceding quantized spectral components in the encoder as well as in the decoder and no additional side information is needed for the transmission of predictor coefficients - as would be required for forward adaptive predictors. A second order backward-adaptive lattice structure predictor is used for each spectral component, so that each predictor is working on the spectral component values of the two preceding frames. The predictor parameters are adapted to the current signal statistics on a frame by frame base, using an LMS based adaptation algorithm. If prediction is activated, the quantizer is fed with a prediction error instead of the original spectral component, resulting in a coding gain.

In order to keep storage requirements to a minimum, predictor state variables are quantized prior to storage.

13.2 Definitions

13.2.1 Data Elements

- predictor_data_present** 1 bit indicating whether prediction is used in current frame (1) or not (0) (always present for ONLY_LONG_SEQUENCE, LONG_START_SEQUENCE and LONG_STOP_SEQUENCE, see subclause 6.3, Table 15).
- predictor_reset** 1 bit indicating whether predictor reset is applied in current frame (1) or not (0) (only present if **predictor_data_present** flag is set, see subclause 6.3, Table 15).
- predictor_reset_group_number** 5 bit number specifying the reset group to be reset in current frame if predictor reset is enabled (only present if **predictor_reset** flag is set, see subclause 6.3, Table 15).

prediction_used

1 bit for each scalefactor band (sfb) where prediction can be used indicating whether prediction is switched on (1) / off (0) in that sfb. If **max_sfb** is less than PRED_SFB_MAX then for i greater than or equal to **max_sfb**, **prediction_used[i]** is not transmitted and therefore is set to off (0) (only present if **predictor_data_present** flag is set, see subclause 6.3, Table 15).

The following Table specifies the upper limit of scalefactor bands up to which prediction can be used:

Table 62 — Upper spectral limit for prediction

Sampling Frequency (Hz)	Pred_SFB_MAX	Number of Predictors	Maximum Frequency using Prediction (Hz)
96000	33	512	24000.00
88200	33	512	22050.00
64000	38	664	20750.00
48000	40	672	15750.00
44100	40	672	14470.31
32000	40	672	10500.00
24000	41	652	7640.63
22050	41	652	7019.82
16000	37	664	5187.50
12000	37	664	3890.63
11025	37	664	3574.51
8000	34	664	2593.75

This means that at 48 kHz sampling rate prediction can be used in scalefactor bands 0 through 39. According to Table 46 these 40 scalefactor bands include the MDCT lines 0 through 671, hence resulting in max. 672 predictors.

13.3 Decoding Process

For each spectral component up to the limit specified by PRED_SFB_MAX of each channel there is one predictor. Prediction is controlled on a `single_channel_element()` or `channel_pair_element()` basis by the transmitted side information in a two step approach, first for the whole frame at all and then conditionally for each scalefactor band individually, see subclause 13.3.1. The predictor coefficients for each predictor are calculated from preceding reconstructed values of the corresponding spectral component. The details of the required predictor processing are described in subclause 13.3.2. At the start of the decoding process, all predictors are initialized. The initialization and a predictor reset mechanism are described in subclause 13.3.2.4.

13.3.1 Predictor Side Information

The following description is valid for either one `single_channel_element()` or one `channel_pair_element()` and has to be applied to each such element. For each frame the predictor side information has to be extracted from the bitstream to control the further predictor processing in the decoder. In case of a `single_channel_element()` the control information is valid for the predictor bank of the channel associated with that element. In case of a `channel_pair_element()` there are the following two possibilities: If **common_window** = 1 then there is only one set of the control information which is valid for the two predictor banks of the two channels associated with that element. If **common_window** = 0 then there are two sets of control information, one for each of the two predictor banks of the two channels associated with that element.

If `window_sequence` is of type `ONLY_LONG_SEQUENCE`, `LONG_START_SEQUENCE` or `LONG_STOP_SEQUENCE`, the **predictor_data_present** bit is read. If this bit is not set (0) then prediction is switched off at all for the current frame and there is no further predictor side information present. In this case the **prediction_used** bit for each scalefactor band stored in the decoder has to be set to zero. If the

predictor_data_present bit is set (1) then prediction is used for the current frame and the **predictor_reset** bit is read which determines whether predictor reset is applied in the current frame (1) or not (0). If **predictor_reset** is set then the next 5 bits are read giving a number specifying the group of predictors to be reset in the current frame, see also subclause 13.3.2.4 for the details. If the **predictor_reset** is not set then there is no 5 bit number in the bitstream. Next, the **prediction_used** bits are read from the bitstream, which control the use of prediction in each scalefactor band individually, i.e. if the bit is set for a particular scalefactor band, then prediction is enabled for all spectral components of this scalefactor band and the quantized prediction error of each spectral component is transmitted instead of the quantized value of the spectral component. Otherwise, prediction is disabled for this scalefactor band and the quantized values of the spectral components are transmitted.

13.3.2 Predictor Processing

13.3.2.1 General

The following description is valid for one single predictor and has to be applied to each predictor. A second order backward adaptive lattice structure predictor is used. Figure 7 shows the corresponding predictor flow graph on the decoder side. In principle, an estimate $x_{est}(n)$ of the current value of the spectral component $x(n)$ is calculated from preceding reconstructed values $x_{rec}(n-1)$ and $x_{rec}(n-2)$, stored in the register elements of the predictor structure, using the predictor coefficients $k_1(n)$ and $k_2(n)$. This estimate is then added to the quantized prediction error $e_q(n)$ reconstructed from the transmitted data resulting in the reconstructed value $x_{rec}(n)$ of the current spectral component $x(n)$. Figure 8 shows the block diagram of this reconstruction process for one single predictor.

Due to the realization in a lattice structure, the predictor consists of two so-called basic elements which are cascaded. In each element, the part $x_{est,m}(n)$, $m=1, 2$ of the estimate is calculated according to

$$x_{est,m}(n) = b \cdot k_m(n) \cdot r_{q,m-1}(n-1),$$

where

$$r_{q,0}(n) = ax_{rec}(n),$$

$$r_{q,1}(n) = a(r_{q,0}(n-1) - b \cdot k_1(n) \cdot e_{q,0}(n))$$

and $e_{q,m}(n) = e_{q,m-1}(n) - x_{est,m}(n)$.

Hence, the overall estimate results to:

$$x_{est}(n) = x_{est,1}(n) + x_{est,2}(n)$$

The constants

$$a \text{ and } b, \quad 0 < a, b \leq 1$$

are attenuation factors which are included in each signal path contributing to the recursivity of the structure for the purpose of stabilization. By this means, possible oscillations due to transmission errors or drift between predictor coefficients on the encoder and decoder side due to numerical inaccuracy can be faded out or even prevented.

In the case of stationary signals and with $a = b = 1$, the predictor coefficient of element m is calculated by

$$k_m = \frac{E[e_{q,m-1}(n) \cdot r_{q,m-1}(n-1)]}{\frac{1}{2} \cdot (E[e_{q,m-1}^2(n)] + E[r_{q,m-1}^2(n-1)])}, \quad m = 1, 2 \text{ and } e_{q,0}(n) = r_{q,0}(n) = x_{rec}(n)$$

In order to adapt the coefficients to the current signal properties, the expected values in the above equation are substituted by time average estimates measured over a limited past signal period. A compromise has to be chosen between a good convergence against the optimum predictor setting for signal periods with quasi stationary characteristic and the ability of fast adaptation in case of signal transitions. In this context algorithms with iterative improvement of the estimates, i.e. from sample to sample, are of special interest. Here, a "least mean square" (LMS) approach is used and the predictor coefficients are calculated as follows

$$k_m(n+1) = \frac{COR_m(n)}{VAR_m(n)}$$

with

$$COR_m(n) = \alpha \cdot COR_m(n-1) + r_{q,m-1}(n-1) \cdot e_{q,m-1}(n)$$

$$VAR_m(n) = \alpha \cdot VAR_m(n-1) + 0.5 \cdot (r_{q,m-1}^2(n-1) + e_{q,m-1}^2(n))$$

where α is an adaptation time constant which determines the influence of the current sample on the estimate of the expected values. The value of α is chosen to

$$\alpha = 0.90625 .$$

The optimum values of the attenuation factors a and b have to be determined as a compromise between high prediction gain and small fade out time. The chosen values are

$$a = b = 0.953125 .$$

Independent of whether prediction is disabled - either at all or only for a particular scalefactor band - or not, all the predictors are run all the time in order to always adapt the coefficients to the current signal statistics.

If `window_sequence` is of type `ONLY_LONG_SEQUENCE`, `LONG_START_SEQUENCE` and `LONG_STOP_SEQUENCE` only the calculation of the reconstructed value of the quantized spectral components differs depending on the value of the **prediction_used** bit:

- If the bit is set (1), then the quantized prediction error reconstructed from the transmitted data is added to the estimate $x_{est}(n)$ calculated by the predictor resulting in the reconstructed value of the quantized spectral component, i.e. $x_{rec}(n) = x_{est}(n) + e_q(n)$
- If the bit is not set (0), then the quantized value of the spectral component is reconstructed directly from the transmitted data.

In case of short blocks, i.e. `window_sequence` is of type `EIGHT_SHORT_SEQUENCE`, prediction is always disabled and a reset is carried out for all predictors in all scalefactor bands, which is equivalent to a reinitialization, see subclause 13.3.2.4.

For a `single_channel_element()`, the predictor processing for one frame is done according to the following pseudo code:

(It is assumed that the reconstructed value $y_{rec}(c)$ - which is either the reconstructed quantized prediction error or the reconstructed quantized spectral coefficient - is available from previous processing.)

```
if (ONLY_LONG_SEQUENCE || LONG_START_SEQUENCE || LONG_STOP_SEQUENCE) {
  for (sfb = 0; sfb < PRED_SFB_MAX; sfb++) {
    fc = swb_offset_long_window[fs_index][sfb];
    lc = swb_offset_long_window[fs_index][sfb+1];
    for (c = fc; c < lc; c++) {
      x_est[c] = predict();
      if (predictor_data_present && prediction_used[sfb])
```

```

        x_rec[c] = x_est[c] + y_rec[c];
    else
        x_rec[c] = y_rec[c];
    }
}
else {
    reset_all_predictors();
}

```

In case of channel_pair_element()'s with **common_window** = 1, the only difference is that the computation of x_{est} and x_{rec} in the inner for loop is done for both channels associated with the channel_pair_element(). In case of channel_pair_element()'s with **common_window** = 0, each channel has prediction applied using that channel's prediction side information.

13.3.2.2 Quantization in Predictor Calculations

For a given predictor six state variables need to be saved: r_0 , r_1 , COR_1 , COR_2 , VAR_1 and VAR_2 . These variables will be saved as truncated IEEE floating-point numbers (i.e. the 16 msb of a float storage word).

The predicted value x_{est} will be rounded to a 16-bit floating point representation (i.e. round to a 7-bit mantissa) prior to being used in any calculation. The exact rounding algorithm to be used is shown in pseudo-C function `flt_round_inf()`. Note that for complexity considerations, *round to nearest, infinity* is used instead of *round to nearest, even*.

The expressions (b / VAR_1) and (b / VAR_2) will be rounded to a 16-bit floating point representation (i.e. round to a 7-bit mantissa), which permits the ratio to be computed via a pair of small look-up tables. C-code for generating such tables is shown in pseudo-C function `make_inv_tables()`.

All intermediate results in every floating point computation in the prediction algorithm will be represented in single precision floating point using rounding described below.

The IEEE Floating Point computational unit used in executing all arithmetic in the prediction tool will enable the following options:

- Round-to-Nearest, Even - Round to nearest representable value; round to the value with the least significant bit equal to zero (even) when the two nearest representable values are equally near.
- Overflow exception - Values whose magnitude is greater than the largest representable value will be set to the representation for infinity.
- Underflow exception - Gradual underflow (de-normalized numbers) will be supported; values whose magnitude is less than the smallest representable value will be set to zero.

13.3.2.3 Fast Algorithm for Rounding

```

/* this does not conform to IEEE conventions of round to
 * nearest, even, but it is fast
 */
static void
flt_round_inf(float *pf)
{
    int flg;
    unsigned long tmp, tmp1, tmp2;

    tmp = *(unsigned long*)pf;
    flg = tmp & (unsigned long)0x00008000;
    tmp &= (unsigned long)0xffff0000;
    tmp1 = tmp;
    /* round 1/2 lsb toward infinity */
    if (flg) {

```



```

tmp &= (unsigned long)0xff800000;      /* extract exponent and sign */
tmp |= (unsigned long)0x00010000;     /* insert 1 lsb */
tmp2 = tmp;                            /* add 1 lsb and elided one */
tmp &= (unsigned long)0xff800000;     /* extract exponent and sign */

*pf = *(float*)&tmp1+*(float*)&tmp2-*(float*)&tmp;
                                     /* subtract elided one */
} else {
*pf = *(float*)&tmp;
}
}

```

13.3.2.4 Generating Rounded b / Var

```

static float mnt_table[128];
static float exp_table[256];

/* function flt_round_even() only works for arguments in the range
 *      1.0 < *pf < 2.0 - 2-24
 */
static void flt_round_even(float *pf)
{
    int exp, a;
    float tmp;

    frexp((double)*pf, &exp);
    tmp = *pf * (1<<(8-exp));
    a = (int)tmp;
    if ((tmp-a) >= 0.5) a++;
    if ((tmp-a) == 0.5) a&=-2;
    *pf = (float)a/(1<<(8-exp));
}

static void make_inv_tables(void)
{
    int i;
    unsigned long tmp1, tmp;
    float *pf = (float *)&tmp1;
    float ftmp;

    *pf = 1.0;
    for (i=0; i<128; i++) {
        tmp = tmp1 + (i<<16);      /* float 1.m, 7 msb only */
        ftmp = b / *(float*)&tmp;
        flt_round_even(&ftmp);    /* round to 16 bits */
        mnt_table[i] = ftmp;
    }
    for (i=0; i<256; i++) {
        tmp = (i<<23);            /* float 1.0 * 2exp */
        if (*(float*)&tmp > 1.0) {
            ftmp = 1.0 / *(float*)&tmp;
        } else {
            ftmp = 0;
        }
        exp_table[i] = ftmp;
    }
}

```

13.3.3 Predictor Reset

Initialization of a predictor means that the predictor's state variables are set as follows: $r_0 = r_1 = 0$, $COR_1 = COR_2 = 0$, $VAR_1 = VAR_2 = 1$. When the decoding process is started, all predictors are initialized.

A cyclic reset mechanism is applied by the encoder and signaled to the decoder, in which all predictors are initialized again in a certain time interval in an interleaved way. On one hand this increases predictor stability by re-synchronizing the predictors of the encoder and the decoder and on the other hand it allows defined entry points in the bitstream.

The whole set of predictors is subdivided into 30 so-called reset groups according to the following table:

Table 63 — Predictor reset groups

<i>Reset group number</i>	<i>Predictors of reset group</i>
1	<i>P0, P30, P60, P90,...</i>
2	<i>P1, P31, P61, P91,...</i>
3	<i>P2, P32, P62, P92,...</i>
...	
30	<i>P29, P59, P89, P119,...</i>

where P_i is the predictor which corresponds to the spectral coefficient indexed by i .

Whether or not a reset has to be applied in the current frame is determined by the **predictor_reset** bit. If this bit is set then the number of the predictor reset group to be reset in the current frame is specified in **predictor_reset_group_number**. All predictors belonging to that reset group are then initialized as described above. This initialization has to be done after the normal predictor processing for the current frame has been carried out. Note that **predictor_reset_group_number** cannot have the value 0 or 31.

A typical reset cycle starts with reset group number 1 and the reset group number is then incremented by 1 until it reaches 30, and then it starts with 1 again. Nevertheless, it may happen, e.g. due to switching between programs (bitstreams) or cutting and pasting, that there will be a discontinuity in the reset group numbering. If this is the case, these are the following three possibilities for decoder operation:

- Ignore the discontinuity and carry on the normal processing. This may result in a short audible distortion due to a mismatch (drift) between the predictors in the encoder and decoder. After one complete reset cycle (reset group $n, n+1, \dots, 30, 1, 2, \dots, n-1$) the predictors are re-synchronized again. Furthermore, a possible distortion is faded out because of the attenuation factors a and b .
- Detect the discontinuity, carry on the normal processing but mute the output until one complete reset cycle is performed and the predictors are re-synchronized again.
- Reset all predictors.

Every predictor group has to be reset after a maximum 'active' period of 240 frames. The reset of the 30 predictor reset groups can be done either intermittently or in a burst or in whatever other pattern is convenient, as long as the maximum reset period of 240 'active' frames is not violated. Note that an 'active' period of 240 frames may take much longer than 240 frames, since frames with predictor activity may be interleaved with an arbitrary number of frames without any predictor activity. Note further, that prediction groups may be active independently of each other, so that separate 'activity' bookkeeping is required for each predictor reset group.

In case of a `single_channel_element()` or a `channel_pair_element()` with **common_window** = 0, the reset has to be applied to the predictor bank(s) of the channel(s) associated with that element. In case of a `channel_pair_element()` with **common_window** = 1, the reset has to be applied to the two predictor banks of the two channels associated with that element.

In the case of a short block (i.e. `window_sequence` of type `EIGHT_SHORT_SEQUENCE`) all predictors in all scalefactor bands must be reset.

13.4 Diagrams

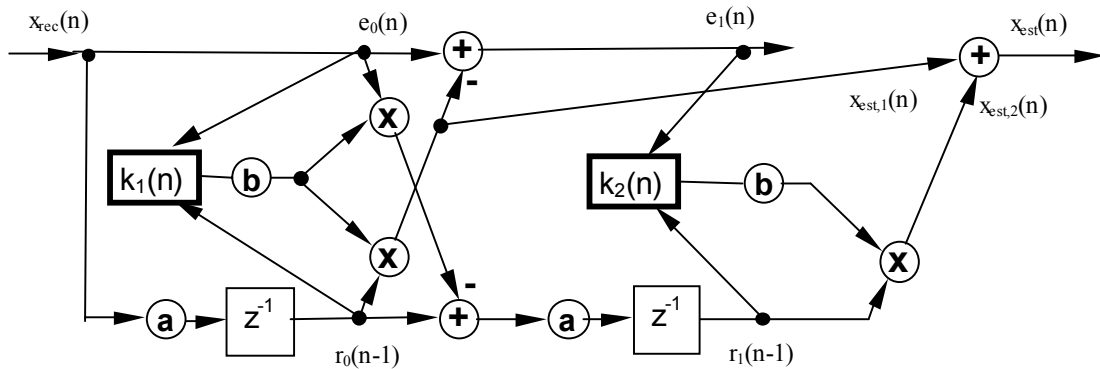
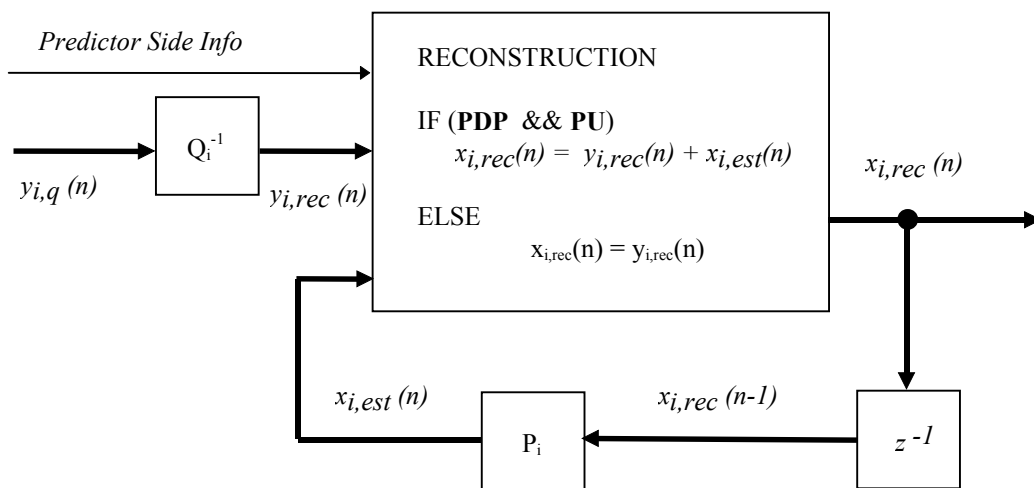

Figure 7 — Flow graph of intra channel predictor for one spectral component in the decoder. The dotted lines indicate the signal flow for the adaptation of the predictor coefficients.



Legend: P Predictor PDP predictor_data-present
 Qi⁻¹ Inverse quantizer PU prediction_used

Figure 8 — Block diagram of decoder prediction unit for one single spectral component

14 Temporal Noise Shaping (TNS)

14.1 Tool Description

Temporal Noise Shaping is used to control the temporal shape of the quantization noise within each window of the transform. This is done by applying a filtering process to parts of the spectral data of each channel.

Note that this tool includes certain profile dependent parameters (see subclause 7.1).

14.2 Definitions

14.2.1 Data Elements

n_filt[w]	Number of noise shaping filters used for window w (see subclause 6.3, Table 19).
coef_res[w]	Token indicating the resolution of the transmitted filter coefficients for window w, switching between a resolution of 3 bits (0) and 4 bits (1) (see subclause 6.3, Table 19).
length[w][filt]	Length of the region to which one filter is applied in window w (in units of scalefactor bands) (see subclause 6.3, Table 19).
order[w][filt]	Order of one noise shaping filter applied to window w (see subclause 6.3, Table 19).
direction[w][filt]	1 bit indicating whether the filter is applied in upward (0) or downward (1) direction (see subclause 6.3, Table 19).
coef_compress[w][filt]	1 bit indicating whether the most significant bit of the coefficients of the noise shaping filter filt in window w are omitted from transmission (1) or not (0) (see subclause 6.3, Table 19).
coef[w][filt][i]	Coefficients of one noise shaping filter applied to window w (see subclause 6.3, Table 19).
spec[w][k]	Array containing the spectrum for the window w of the channel being processed.

Note: Depending on the window_sequence the size of the following bitstream fields is switched for each transform window according to its window size:

Name	Window with 128 spectral lines	Other window size
'n_filt'	1	2
'length'	4	6
'order'	3	5

14.3 Decoding Process

The decoding process for Temporal Noise Shaping is carried out separately on each window of the current frame by applying all-pole filtering to selected regions of the spectral coefficients (see function tns_decode_frame).

The number of noise shaping filters applied to each window is specified by "n_filt". The target range of spectral coefficients is defined in units of scalefactor bands counting down "length" bands from the top band (or the bottom of the previous noise shaping band).

First the transmitted filter coefficients have to be decoded, i.e. conversion to signed numbers, inverse quantization, conversion to LPC coefficients as described in function tns_decode_coef().

Then the all-pole filters are applied to the target frequency regions of the channel's spectral coefficients (see function tns_ar_filter()). The token "direction" is used to determine the direction the filter is slid across the coefficients (0 = upward, 1 = downward).

The constant TNS_MAX_BANDS defines the maximum number of scalefactor bands to which Temporal Noise Shaping is applied. The maximum possible filter order is defined by the constant TNS_MAX_ORDER. Both constants are profile dependent parameters.

The decoding process for one channel can be described as follows pseudo code:

```

/* TNS decoding for one channel and frame */
tns_decode_frame()
{
    for (w = 0; w < num_windows; w++) {
        bottom = num_swb;
        for (f = 0; f < n_filt[w]; f++) {
            top = bottom;
            bottom = max(top - length[w][f], 0);
            tns_order = min(order[w][f], TNS_MAX_ORDER);
            if (!tns_order) continue;
            tns_decode_coef(tns_order, coef_res[w]+3, coef_compress[w][f],
                           coef[w][f], lpc[]);
            start = swb_offset[min(bottom, TNS_MAX_BANDS, max_sfb)];
            end = swb_offset[min(top, TNS_MAX_BANDS, max_sfb)];
            if ((size = end - start) <= 0) continue;
            if (direction[w][f]) {
                inc = -1; start = end - 1;
            } else {
                inc = 1;
            }
            tns_ar_filter(&spec[w][start], size, inc, lpc[], tns_order);
        }
    }
}

```

Please note that this pseudo code uses a C-style interpretation of arrays and vectors, i.e. if `coef[w][filt][i]` describes the coefficients for all windows and filters, `coef[w][filt]` is a pointer to the coefficients of one particular window and filter. Also, the identifier `coef` is used as a formal parameter in function `tns_decode_coef()`.

```

/* Decoder transmitted coefficients for one TNS filter */
tns_decode_coef(order, coef_res_bits, coef_compress, coef[], a[])
{
    /* Some internal tables */
    sgn_mask[] = { 0x2, 0x4, 0x8 };
    neg_mask[] = { ~0x3, ~0x7, ~0xf };

    /* size used for transmission */
    coef_res2 = coef_res_bits - coef_compress;
    s_mask = sgn_mask[coef_res2 - 2]; /* mask for sign bit */
    n_mask = neg_mask[coef_res2 - 2]; /* mask for padding neg. values */

    /* Conversion to signed integer */
    for (i = 0; i < order; i++)
        tmp[i] = (coef[i] & s_mask) ? (coef[i] | n_mask) : coef[i];

    /* Inverse quantization */
    iqfac = ((1 << (coef_res_bits-1)) - 0.5) / (pi/2.0);
    iqfac_m = ((1 << (coef_res_bits-1)) + 0.5) / (pi/2.0);
    for (i = 0; i < order; i++) {
        tmp2[i] = sin(tmp[i] / ((tmp[i] >= 0) ? iqfac : iqfac_m));
    }

    /* Conversion to LPC coefficients */
    a[0] = 1;
    for (m = 1; m <= order; m++) {
        for (i = 1; i < m; i++) {
            b[i] = a[i] + tmp2[m-1] * a[m-i];
        }
    }
}

```

```

    for (i = 1; i < m; i++) {
        a[i] = b[i];
    }
    a[m] = tmp2[m-1];
}
}

tns_ar_filter(spectrum[], size, inc, lpc[], order)
{
- Simple all-pole filter of order "order" defined by
   $y(n) = x(n) - lpc[1]*y(n-1) - \dots - lpc[order]*y(n-order)$ 

- The state variables of the filter are initialized to zero every time

- The output data is written over the input data ("in-place operation")

- An input vector of "size" samples is processed and the index increment
  to the next data sample is given by "inc"
}

```

15 Filterbank and Block Switching

15.1 Tool Description

The time-frequency representation of the signal is mapped onto the time domain by feeding it into the filterbank module. This module consists of an inverse modified discrete cosine transform (IMDCT), and a window and an overlap-add function. In order to adapt the time/frequency resolution of the filterbank to the characteristics of the input signal, a block switching tool is also adopted. N represents the window length, where N is a function of the **window_sequence**, see subclause 8.3.3. For each channel, the N/2 time-frequency values $X_{i,k}$ are transformed into the N time domain values $x_{i,n}$ via the IMDCT. After applying the window function, for each channel, the first half of the $z_{i,n}$ sequence is added to the second half of the previous block windowed sequence $z_{(i-1),n}$ to reconstruct the output samples for each channel $out_{i,n}$.

15.2 Definitions

The syntax elements for the filterbank are specified in the raw data stream for the **single_channel_element()** (see subclause 6.3, Table 13), **channel_pair_element()** (see subclause 6.3, Table 14), and the **coupling_channel** (see subclause 6.3, Table 22). They consist of the control information **window_sequence** and **window_shape**.

15.2.1 Data Elements

window_sequence	2 bit indicating which window sequence (i.e. block size) is used (see subclause 6.3, Table 15).
window_shape	1 bit indicating which window function is selected (see subclause 6.3, Table 15).

Table 44 shows the four **window_sequences** (ONLY_LONG_SEQUENCE, LONG_START_SEQUENCE, EIGHT_SHORT_SEQUENCE, LONG_STOP_SEQUENCE).

15.3 Decoding Process

15.3.1 IMDCT

The analytical expression of the IMDCT is:

$$x_{i,n} = \frac{2}{N} \sum_{k=0}^{\frac{N}{2}-1} \text{spec}[i][k] \cos\left(\frac{2\pi}{N} (n + n_0) \left(k + \frac{1}{2}\right)\right) \quad \text{for } 0 \leq n < N$$

where :

n = sample index

i = window index

k = spectral coefficient index

N = window length based on the window_sequence value

$$n_0 = (N/2 + 1)/2$$

The synthesis window length N for the inverse transform is a function of the syntax element **window_sequence** and is defined as follows:

$$N = \begin{cases} 2048, & \text{if ONLY_LONG_SEQUENCE (0x0)} \\ 2048, & \text{if LONG_START_SEQUENCE (0x1)} \\ 256, & \text{if EIGHT_SHORT_SEQUENCE (0x2), (8 times)} \\ 2048, & \text{if LONG_STOP_SEQUENCE (0x3)} \end{cases}$$

The meaningful block transitions are as follows:

from ONLY_LONG_SEQUENCE to { ONLY_LONG_SEQUENCE
LONG_START_SEQUENCE

from LONG_START_SEQUENCE to { EIGHT_SHORT_SEQUENCE
LONG_STOP_SEQUENCE

from LONG_STOP_SEQUENCE to { ONLY_LONG_SEQUENCE
LONG_START_SEQUENCE

from EIGHT_SHORT_SEQUENCE to { EIGHT_SHORT_SEQUENCE
LONG_STOP_SEQUENCE

In addition to the meaningful block transitions the following transitions are possible:

from ONLY_LONG_SEQUENCE to { EIGHT_SHORT_SEQUENCE
LONG_STOP_SEQUENCE

from LONG_START_SEQUENCE to { ONLY_LONG_SEQUENCE
LONG_START_SEQUENCE

from LONG_STOP_SEQUENCE to { EIGHT_SHORT_SEQUENCE
LONG_STOP_SEQUENCE

from EIGHT_SHORT_SEQUENCE to { ONLY_LONG_SEQUENCE
LONG_START_SEQUENCE

This will still result in a reasonably smooth transition from one block to the next.

15.3.2 Windowing and Block Switching

Depending on the **window_sequence** and **window_shape** element different transform windows are used. A combination of the window halves described as follows offers all possible window_sequences.

For **window_shape** == 1, the window coefficients are given by the Kaiser - Bessel derived (KBD) window as follows:

$$W_{KBD_LEFT,N}(n) = \frac{\sum_{p=0}^n [W'(p, \alpha)]}{\sum_{p=0}^{N/2} [W'(p, \alpha)]} \quad \text{for } 0 \leq n < \frac{N}{2}$$

$$W_{KBD_RIGHT,N}(n) = \frac{\sum_{p=0}^{N-n-1} [W'(p, \alpha)]}{\sum_{p=0}^{N/2} [W'(p, \alpha)]} \quad \text{for } \frac{N}{2} \leq n < N$$

where:

W' (Kaiser-Bessel kernel window function, see also **Error! Reference source not found.**) is defined as follows:

$$W'(n, \alpha) = \frac{I_0 \left[\pi \alpha \sqrt{1.0 - \left(\frac{n - N/4}{N/4} \right)^2} \right]}{I_0[\pi \alpha]} \quad \text{for } 0 \leq n \leq \frac{N}{2}$$

$$I_0[x] = \sum_{k=0}^{\infty} \left[\frac{\left(\frac{x}{2} \right)^k}{k!} \right]^2$$

α = kernel window alpha factor, $\alpha = \begin{cases} 4 & \text{for } N = 2048 \\ 6 & \text{for } N = 256 \end{cases}$

Otherwise, for **window_shape** == 0, a sine window is employed as follows:

$$W_{SIN_LEFT,N}(n) = \sin\left(\frac{\pi}{N} \left(n + \frac{1}{2}\right)\right) \quad \text{for } 0 \leq n < \frac{N}{2}$$

$$W_{SIN_RIGHT,N}(n) = \sin\left(\frac{\pi}{N} \left(n + \frac{1}{2}\right)\right) \quad \text{for } \frac{N}{2} \leq n < N$$

The window length N can be 2048 or 256 for the KBD and the sine window. How to obtain the possible window sequences is explained in the parts a) - d) of this clause. All four window_sequences described below have a total length of 2048 samples.

For all kinds of window_sequences the window_shape of the left half of the first transform window is determined by the window shape of the previous block. The following formula expresses this fact:

$$W_{LEFT,N}(n) = \begin{cases} W_{KBD_LEFT,N}(n), & \text{if } window_shape_previous_block == 1 \\ W_{SIN_LEFT,N}(n), & \text{if } window_shape_previous_block == 0 \end{cases}$$

where:

window_shape_previous_block: **window_shape** of the previous block (i-1).

For the first block of the bitstream to be decoded the **window_shape** of the left and right half of the window are identical.

a) ONLY_LONG_SEQUENCE:

The **window_sequence** == ONLY_LONG_SEQUENCE is equal to one LONG_WINDOW (see Table 44) with a total window length of 2048.

For **window_shape** == 1 the window for ONLY_LONG_SEQUENCE is given as follows:

$$W(n) = \begin{cases} W_{LEFT,2048}(n), & \text{for } 0 \leq n < 1024 \\ W_{KBD_RIGHT,2048}(n), & \text{for } 1024 \leq n < 2048 \end{cases}$$

If **window_shape** == 0 the window for ONLY_LONG_SEQUENCE can be described as follows:

$$W(n) = \begin{cases} W_{LEFT,2048}(n), & \text{for } 0 \leq n < 1024 \\ W_{SIN_RIGHT,2048}(n), & \text{for } 1024 \leq n < 2048 \end{cases}$$

After windowing, the time domain values ($z_{i,n}$) can be expressed as:

$$z_{i,n} = w(n) \cdot x_{i,n};$$

b) LONG_START_SEQUENCE:

The LONG_START_SEQUENCE is needed to obtain a correct overlap and add for a block transition from a ONLY_LONG_SEQUENCE to a EIGHT_SHORT_SEQUENCE.

If **window_shape** == 1 the window for LONG_START_SEQUENCE is given as follows:

$$W(n) = \begin{cases} W_{LEFT,2048}(n), & \text{for } 0 \leq n < 1024 \\ 1.0, & \text{for } 1024 \leq n < 1472 \\ W_{KBD_RIGHT,256}(n + 128 - 1472), & \text{for } 1472 \leq n < 1600 \\ 0.0, & \text{for } 1600 \leq n < 2048 \end{cases}$$

If **window_shape** == 0 the window for LONG_START_SEQUENCE looks like:

$$W(n) = \begin{cases} W_{LEFT,2048}(n), & \text{for } 0 \leq n < 1024 \\ 1.0, & \text{for } 1024 \leq n < 1472 \\ W_{SIN_RIGHT,256}(n + 128 - 1472), & \text{for } 1472 \leq n < 1600 \\ 0.0, & \text{for } 1600 \leq n < 2048 \end{cases}$$

The windowed time-domain values can be calculated with the formula explained in a).

c) EIGHT_SHORT

The **window_sequence** == EIGHT_SHORT comprises eight overlapped and added SHORT_WINDOWS (see Table 44) with a length of 256 each. The total length of the window_sequence together with leading and following zeros is 2048. Each of the eight short blocks are windowed separately first. The short block number is indexed with the variable $j = 0, \dots, 7$.

The **window_shape** of the previous block influences the first of the eight short blocks ($W_0(n)$) only.

If **window_shape** == 1 the window functions can be given as follows:

$$W_0(n) = \begin{cases} W_{LEFT,256}(n), & \text{for } 0 \leq n < 128 \\ W_{KBD_RIGHT,256}(n), & \text{for } 128 \leq n < 256 \end{cases}$$

$$W_{1-7}(n) = \begin{cases} W_{KBD_LEFT,256}(n), & \text{for } 0 \leq n < 128 \\ W_{KBD_RIGHT,256}(n), & \text{for } 128 \leq n < 256 \end{cases}$$

Otherwise, if **window_shape** == 0, the window functions can be described as:

$$W_0(n) = \begin{cases} W_{LEFT,256}(n), & \text{for } 0 \leq n < 128 \\ W_{SIN_RIGHT,256}(n), & \text{for } 128 \leq n < 256 \end{cases}$$

$$W_{1-7}(n) = \begin{cases} W_{SIN_LEFT,256}(n), & \text{for } 0 \leq n < 128 \\ W_{SIN_RIGHT,256}(n), & \text{for } 128 \leq n < 256 \end{cases}$$

The overlap and add between the EIGHT_SHORT **window_sequence** resulting in the windowed time domain values $z_{i,n}$ is described as follows:

$$z_{i,n} = \begin{cases} 0, & \text{for } 0 \leq n < 448 \\ x_{i,n-448} \cdot W_0(n-448), & \text{for } 448 \leq n < 576 \\ x_{i,n-448} \cdot W_0(n-448) + x_{i,n-576} \cdot W_1(n-576), & \text{for } 576 \leq n < 704 \\ x_{i,n-576} \cdot W_1(n-576) + x_{i,n-704} \cdot W_2(n-704), & \text{for } 704 \leq n < 832 \\ x_{i,n-704} \cdot W_2(n-704) + x_{i,n-832} \cdot W_3(n-832), & \text{for } 832 \leq n < 960 \\ x_{i,n-832} \cdot W_3(n-832) + x_{i,n-960} \cdot W_4(n-960), & \text{for } 960 \leq n < 1088 \\ x_{i,n-960} \cdot W_4(n-960) + x_{i,n-1088} \cdot W_5(n-1088), & \text{for } 1088 \leq n < 1216 \\ x_{i,n-1088} \cdot W_5(n-1088) + x_{i,n-1216} \cdot W_6(n-1216), & \text{for } 1216 \leq n < 1344 \\ x_{i,n-1216} \cdot W_6(n-1216) + x_{i,n-1344} \cdot W_7(n-1344), & \text{for } 1344 \leq n < 1472 \\ x_{i,n-1344} \cdot W_7(n-1344), & \text{for } 1472 \leq n < 1600 \\ 0, & \text{for } 1600 \leq n < 2048 \end{cases}$$

d) LONG_STOP_SEQUENCE

This window_sequence is needed to switch from a EIGHT_SHORT_SEQUENCE back to a ONLY_LONG_SEQUENCE.

If **window_shape** == 1 the window for LONG_STOP_SEQUENCE is given as follows:

$$W(n) = \begin{cases} 0.0, & \text{for } 0 \leq n < 448 \\ W_{LEFT,256}(n-448), & \text{for } 448 \leq n < 576 \\ 1.0, & \text{for } 576 \leq n < 1024 \\ W_{KBD_RIGHT,2048}(n), & \text{for } 1024 \leq n < 2048 \end{cases}$$

If **window_shape** == 0 the window for LONG_START_SEQUENCE is determined by:

$$W(n) = \begin{cases} 0.0, & \text{for } 0 \leq n < 448 \\ W_{LEFT,256}(n-448), & \text{for } 448 \leq n < 576 \\ 1.0, & \text{for } 576 \leq n < 1024 \\ W_{SIN_RIGHT,2048}(n), & \text{for } 1024 \leq n < 2048 \end{cases}$$

The windowed time domain values can be calculated with the formula explained in a).

15.3.3 Overlapping and Adding with Previous Window Sequence

Besides the overlap and add within the EIGHT_SHORT **window_sequence** the first (left) half of every **window_sequence** is overlapped and added with the second (right) half of the previous **window_sequence** resulting in the final time domain values $out_{i,n}$. The mathematic expression for this operation can be described as follows. It is valid for all four possible **window_sequences**.

$$out_{i,n} = z_{i,n} + z_{i-1, n + \frac{N}{2}}; \quad \text{for } 0 \leq n < \frac{N}{2}, \quad N = 2048$$

16 Gain Control

16.1 Tool Description

The gain control tool is made up of several gain compensators and overlap/add processing stages, and an IPQF (Inverse Polyphase Quadrature Filter) stage. This tool receives non-overlapped signal sequences provided by the IMDCT stages, **window_sequence** and **gain_control_data**, and then reproduces the output PCM data. The block diagram for the gain control tool is shown in Figure 9.

Due to the characteristics of the PQF filterbank, the order of the MDCT coefficients in each even PQF band must be reversed. This is done by reversing the spectral order of the MDCT coefficients, i.e. exchanging the higher frequency MDCT coefficients with the lower frequency MDCT coefficients.

If the gain control tool is used, the configuration of the filter bank tool is changed as follows. In the case of an EIGHT_SHORT_SEQUENCE **window_sequence**, the number of coefficients for the IMDCT is 32 instead of 128 and eight IMDCTs are carried out. In the case of other **window_sequence** values, the number of coefficients for the IMDCT is 256 instead of 1024 and one IMDCT is performed. In all cases, the filter bank tool outputs a total of 2048 non-overlapped values per frame. These values are supplied to the gain control tool as $U_{W,B}(j)$ defined in 16.3.3.

The IPQF combines four uniform frequency bands and produces a decoded time domain output signal. The aliasing components introduced by the PQF in the encoder are cancelled by the IPQF.

The gain values for each band can be controlled independently except for the lowest frequency band. The step size of gain control is 2^n where n is an integer.

The gain control tool outputs a time signal sequence which is $AS(n)$ defined in 16.3.4.

16.2 Definitions

16.2.1 Data Elements

adjust_num	3-bit field indicating the number of gain changes for each IPQF band. The maximum number of gain changes is seven (see subclause 6.3, Table 27).
max_band	2-bit field indicating the number of IPQF bands in which their signal gain have been controlled. The meanings of this value are shown below (see subclause 6.3, Table 27). 0: no bands have activated gain control. 1: signal gain on 2nd IPQF band has been controlled. 2: signal gain on 2nd and 3rd IPQF bands have been controlled. 3: signal gain on 2nd, 3rd and 4th IPQF bands have been controlled.
alevcode	4-bit field indicating the gain value for one gain change (see subclause 6.3, Table 27).
aloccode	2-, 4-, or 5-bit field indicating the position for one gain change. The length of this data varies depending on the window sequence (see subclause 6.3, Table 27).

16.2.2 Help Elements

<i>gain control data</i>	side information indicating the gain values and the positions used for the gain change.
<i>IPQF band</i>	each split band of IPQF.

16.3 Decoding Process

The following four processes are required for decoding.

- (1) Gain control data decoding
- (2) Gain control function setting
- (3) Gain control windowing and overlapping
- (4) Synthesis filter

16.3.1 Gain Control Data Decoding

Gain control data are reconstructed as follows.

(1)

$$NAD_{w,B} = \text{adjust_num}[B][W]$$

(2)

$$ALOC_{W,B}(m) = AdjLoc(alocode[B][W][m-1]), 1 \leq m \leq NAD_{W,B}$$

$$ALEV_{W,B}(m) = 2^{AdjLev(alocode[B][W][m-1])}, 1 \leq m \leq NAD_{W,B}$$

(3)

$$ALOC_{W,B}(0) = 0$$

$$ALEV_{W,B}(0) = \begin{cases} 1, & \text{if } NAD_{W,B} == 0 \\ ALEV_{W,B}(1), & \text{otherwise} \end{cases}$$

(4)

$$ALOC_{W,B}(NAD_{W,B} + 1) = \begin{cases} \left. \begin{array}{l} 256, W == 0 \text{ if } \text{ONLY_LONG_SEQUENCE} \\ 112, W == 0 \\ 32, W == 1 \end{array} \right\} \text{if } \text{LONG_START_SEQUENCE} \\ 32, 0 \leq W \leq 7 \text{ if } \text{EIGHT_SHORT_SEQUENCE} \\ \left. \begin{array}{l} 112, W == 0 \\ 256, W == 1 \end{array} \right\} \text{if } \text{LONG_STOP_SEQUENCE} \end{cases}$$

$$ALEV_{W,B}(NAD_{W,B} + 1) = 1$$

where

$NAD_{W,B}$: Gain Control Information Number, an integer

$ALOC_{W,B}(m)$: Gain Control Location, an integer

$ALEV_{W,B}(m)$: Gain Control Level, an integer-valued real number

B : Band ID, an integer from 1 to 3

W : Window ID, an integer from 0 to 7

m : an integer

$alocode[B][W][m]$ must be set so that $\{ALOC_{W,B}(m)\}$ satisfies the following conditions.

$$ALOC_{W,B}(m_1) < ALOC_{W,B}(m_2), 1 \leq m_1 < m_2 \leq NAD_{W,B} + 1$$

In cases of LONG_START_SEQUENCE and LONG_STOP_SEQUENCE, the values 14 and 15 of $alocode[B][0][m]$ are invalid. $AdjLoc()$ is defined in Table 64. $AdjLev()$ is defined in Table 65.

16.3.2 Gain Control Function Setting

The Gain control function is obtained as follows.

(1)

$$M_{W,B,j} = \text{Max}\{m : ALOC_{W,B}(m) \leq j\},$$

$$0 \leq j \leq 255, W == 0 \text{ if } \text{ONLY_LONG_SEQUENCE}$$

$$\left. \begin{array}{l} 0 \leq j \leq 111, W == 0 \\ 0 \leq j \leq 31, W == 1 \end{array} \right\} \text{if } \text{LONG_START_SEQUENCE}$$

$$0 \leq j \leq 31, 0 \leq W \leq 7 \text{ if } \text{EIGHT_SHORT_SEQUENCE}$$

$$\left. \begin{array}{l} 0 \leq j \leq 111, W == 0 \\ 0 \leq j \leq 255, W == 1 \end{array} \right\} \text{if } \text{LONG_STOP_SEQUENCE}$$

(2)

$$FMD_{W,B}(j) = \begin{cases} \text{Inter} \left(\begin{array}{l} ALEV_{W,B}(M_{W,B,j}) \\ ALEV_{W,B}(M_{W,B,j} + 1) \end{array} \right), \\ \left(j - ALOC_{W,B}(M_{W,B,j}) \right) \\ \text{if } ALOC_{W,B}(M_{W,B,j}) \leq j \leq ALOC_{W,B}(M_{W,B,j}) + 7 \\ ALEV_{W,B}(M_{W,B,j} + 1), \text{ otherwise} \end{cases}$$

(3)

if ONLY_LONG_SEQUENCE

$$GMF_{0,B}(j) = \begin{cases} ALEV_{0,B}(0) \times PFMD_B(j), 0 \leq j \leq 255 \\ FMD_{0,B}(j - 256), 256 \leq j \leq 511 \end{cases}$$

$$PFMD_B(j) = FMD_{0,B}(j), 0 \leq j \leq 255$$

if LONG_START_SEQUENCE

$$GMF_{0,B}(j) = \begin{cases} ALEV_{0,B}(0) \times ALEV_{1,B}(0) \times PFMD_B(j), 0 \leq j \leq 255 \\ ALEV_{1,B}(0) \times FMD_{0,B}(j - 256), 256 \leq j \leq 367 \\ FMD_{1,B}(j - 368), 368 \leq j \leq 399 \\ 1, 400 \leq j \leq 511 \end{cases}$$

$$PFMD_B(j) = FMD_{1,B}(j), 0 \leq j \leq 31$$

if EIGHT_SHORT_SEQUENCE

$$GMF_{W,B}(j) = \begin{cases} ALEV_{W,B}(0) \times PFMD_B(j), W == 0, 0 \leq j \leq 31 \\ ALEV_{W,B}(0) \times FMD_{W-1,B}(j), 1 \leq W \leq 7, 0 \leq j \leq 31 \\ FMD_{W,B}(j-32), 0 \leq W \leq 7, 32 \leq j \leq 63 \end{cases}$$

$$PFMD_B(j) = FMD_{7,B}(j), 0 \leq j \leq 31$$

if LONG_STOP_SEQUENCE

$$GMF_{0,B}(j) = \begin{cases} 1, 0 \leq j \leq 111 \\ ALEV_{0,B}(0) \times ALEV_{1,B}(0) \times PFMD_B(j-112), 112 \leq j \leq 143 \\ ALEV_{1,B}(0) \times FMD_{0,B}(j-144), 144 \leq j \leq 255 \\ FMD_{1,B}(j-256), 256 \leq j \leq 511 \end{cases}$$

$$PFMD_B(j) = FMD_{1,B}(j), 0 \leq j \leq 255$$

(4)

$$AD_{W,B}(j) = \frac{1}{GMF_{W,B}(j)},$$

$$0 \leq j \leq 511, W == 0 \text{ if ONLY_LONG_SEQUENCE}$$

$$0 \leq j \leq 511, W == 0 \text{ if LONG_START_SEQUENCE}$$

$$0 \leq j \leq 63, 0 \leq W \leq 7 \text{ if EIGHT_SHORT_SEQUENCE}$$

$$0 \leq j \leq 511, W == 0 \text{ if LONG_STOP_SEQUENCE}$$

where

$FMD_{W,B}(j)$: Fragment Modification Function, a real number

$PFMD_B(j)$: Fragment Modification Function of previous frame, a real number

$GMF_{W,B}(j)$: Gain Modification Function, a real number

$AD_{W,B}(j)$: Gain Control Function, a real number

$ALOC_{W,B}(m)$: Gain Control Location defined in subclause 16.3.1, an integer

$ALEV_{W,B}(m)$: Gain Control Level defined in subclause 16.3.1, an integer-valued real number

B : Band ID, an integer from 1 to 3

W : Window ID, an integer from 0 to 7

$M_{W,B,j}$: an integer

m : an integer

and

$$Inter(a,b,j) = 2^{\frac{(8-j)\log_2(a) + j\log_2(b)}{8}}$$

Note that the initial value of $PFMD_B(j)$ must be set 1.0.

16.3.3 Gain Control Windowing and Overlapping

Band Sample Data are obtained through the processes (1) to (2) shown below.

(1) Gain Control Windowing

if $B = 0$

$$T_{W,B}(j) = U_{W,B}(j),$$

$$0 \leq j \leq 511, W == 0 \text{ if } \text{ONLY_LONG_SEQUENCE}$$

$$0 \leq j \leq 511, W == 0 \text{ if } \text{LONG_START_SEQUENCE}$$

$$0 \leq j \leq 63, 0 \leq W \leq 7 \text{ if } \text{EIGHT_SHORT_SEQUENCE}$$

$$0 \leq j \leq 511, W == 0 \text{ if } \text{LONG_STOP_SEQUENCE}$$

else

$$T_{W,B}(j) = AD_{W,B}(j) \times U_{W,B}(j),$$

$$0 \leq j \leq 511, W == 0 \text{ if } \text{ONLY_LONG_SEQUENCE}$$

$$0 \leq j \leq 511, W == 0 \text{ if } \text{LONG_START_SEQUENCE}$$

$$0 \leq j \leq 63, 0 \leq W \leq 7 \text{ if } \text{EIGHT_SHORT_SEQUENCE}$$

$$0 \leq j \leq 511, W == 0 \text{ if } \text{LONG_STOP_SEQUENCE}$$

(2) Overlapping

if $\text{ONLY_LONG_SEQUENCE}$

$$V_B(j) = PT_B(j) + T_{0,B}(j), 0 \leq j \leq 255$$

$$PT_B(j) = T_{0,B}(j + 256), 0 \leq j \leq 255$$

if LONG_START_SEQUENCE

$$V_B(j) = PT_B(j) + T_{0,B}(j), 0 \leq j \leq 255$$

$$V_B(j + 256) = T_{0,B}(j + 256), 0 \leq j \leq 111$$

$$PT_B(j) = T_{0,B}(j + 368), 0 \leq j \leq 31$$

if EIGHT_SHORT_SEQUENCE

$$V_B(j) = PT_B(j) + T_{W,B}(j), W \neq 0, 0 \leq j \leq 31$$

$$V_B(32W + j) = T_{W-1,B}(j + 32) + T_{W,B}(j), 1 \leq W \leq 7, 0 \leq j \leq 31$$

$$PT_B(j) = T_{W,B}(j + 32), W \neq 7, 0 \leq j \leq 31$$

if LONG_STOP_SEQUENCE

$$V_B(j) = PT_B(j) + T_{0,B}(j + 112), 0 \leq j \leq 31$$

$$V_B(j + 32) = T_{0,B}(j + 144), 0 \leq j \leq 111$$

$$PT_B(j) = T_{0,B}(j + 256), 0 \leq j \leq 255$$

where

$U_{W,B}(j)$: Band Spectrum Data, a real number

$T_{W,B}(j)$: Gain Controlled Block Sample Data, a real number

$PT_B(j)$: Gain Controlled Block Sample Data of previous frame, a real number

$V_B(j)$: Band Sample Data, a real number

$AD_{W,B}(j)$: Gain Control Function defined in subclause 16.3.2, a real number

B : Band ID, an integer from 0 to 3

W : Window ID, an integer from 0 to 7

j : an integer

Note that the initial value of $PT_B(j)$ must be set 0.0.

16.3.4 Synthesis Filter

Audio Sample Data are obtained from the following equations.

(1)

$$\tilde{V}_B(j) = \begin{cases} V_B(k), & \text{if } j = 4k, \\ 0, & \text{else} \end{cases} \quad 0 \leq B \leq 3$$

(2)

$$Q_B(j) = Q(j) \times \cos\left(\frac{(2B+1)(2j-3)\pi}{16}\right), \quad 0 \leq j \leq 95, 0 \leq B \leq 3$$

(3)

$$AS(n) = \sum_{B=0}^3 \sum_{j=0}^{95} Q_B(j) \times \tilde{V}_B(n-j)$$

where

$AS(n)$: Audio Sample Data

$V_B(n)$: Band Sample Data defined in subclause 16.3.3, a real number

$\tilde{V}_B(j)$: Interpolated Band Sample Data, a real number

$Q_B(j)$: Synthesis Filter Coefficients, a real number

$Q(j)$: Prototype Coefficients given below, a real number

B : Band ID, an integer from 0 to 3

W : Window ID, an integer from 0 to 7

n : an integer

j : an integer

k : an integer

The values of $Q(0)$ to $Q(47)$ are shown in Table 66. The values of $Q(48)$ to $Q(95)$ are obtained from the following equation.

$$Q(j) = Q(95-j), \quad 48 \leq j \leq 95$$

16.4 Diagrams

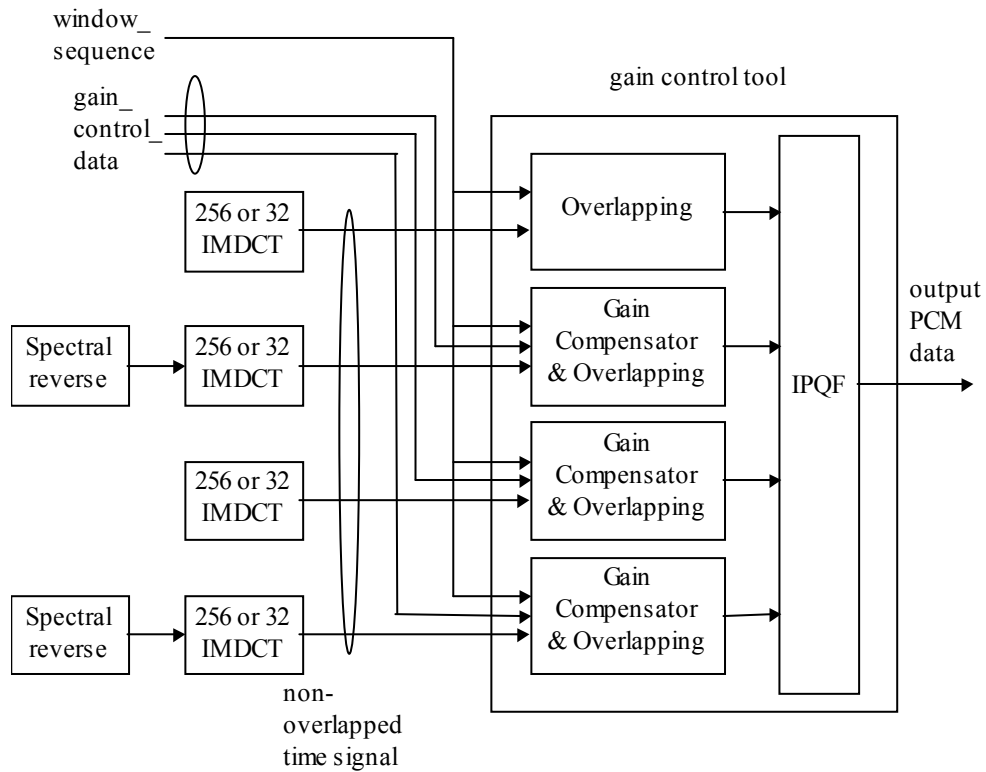

Figure 9 — Block diagram of gain control tool

16.5 Tables

Table 64 — AdjLoc()

AC	AdjLoc(AC)	AC	AdjLoc(AC)
0	0	16	128
1	8	17	136
2	16	18	144
3	24	19	152
4	32	20	160
5	40	21	168
6	48	22	176
7	56	23	184
8	64	24	192
9	72	25	200
10	80	26	208
11	88	27	216
12	96	28	224
13	104	29	232
14	112	30	240
15	120	31	248

Table 65 — AdjLev()

AV	AdjLev(AV)
0	-4
1	-3
2	-2
3	-1
4	0
5	1
6	2
7	3
8	4
9	5
10	6
11	7
12	8
13	9
14	10
15	11

Table 66 — Q()

j	Q(j)	j	Q(j)
0	9.7655291007575512E-05	24	-2.2656858741499447E-02
1	1.3809589379038567E-04	25	-6.8031113858963354E-03
2	9.8400749256623534E-05	26	1.5085400948280744E-02
3	-8.6671544782335723E-05	27	3.9750993388272739E-02
4	-4.6217998911921346E-04	28	6.2445363629436743E-02
5	-1.0211814095158174E-03	29	7.7622327748721326E-02
6	-1.6772149340010668E-03	30	7.9968338496132926E-02
7	-2.2533338951411081E-03	31	6.5615493068475583E-02
8	-2.4987888343213967E-03	32	3.3313658300882690E-02
9	-2.1390815966761882E-03	33	-1.4691563058190206E-02
10	-9.5595397454597772E-04	34	-7.2307890475334147E-02
11	1.1172111530118943E-03	35	-1.2993222541703875E-01
12	3.9091309127348584E-03	36	-1.7551641029040532E-01
13	6.9635703420118673E-03	37	-1.9626543957670528E-01
14	9.5595442159478339E-03	38	-1.8073330670215029E-01
15	1.0815766540021360E-02	39	-1.2097653136035738E-01
16	9.8770514991715300E-03	40	-1.4377370758549035E-02
17	6.1562567291327357E-03	41	1.3522730742860303E-01
18	-4.1793946063629710E-04	42	3.1737852699301633E-01
19	-9.2128743097707640E-03	43	5.1590021798482233E-01
20	-1.8830775873369020E-02	44	7.1080020379761377E-01
21	-2.7226498457701823E-02	45	8.8090632488444798E-01
22	-3.2022840857588906E-02	46	1.0068321641150089E+00
23	-3.0996332527754609E-02	47	1.0737914947736096E+00

Annex A (normative)

Huffman Codebook Tables

Table A.1 — Scalefactor Huffman Codebook

index	length	codeword (hexadecimal)	index	length	codeword (hexadecimal)
0	18	3ffe8	61	4	a
1	18	3ffe6	62	4	c
2	18	3ffe7	63	5	1b
3	18	3ffe5	64	6	39
4	19	7fff5	65	6	3b
5	19	7fff1	66	7	78
6	19	7ffed	67	7	7a
7	19	7fff6	68	8	f7
8	19	7ffee	69	8	f9
9	19	7ffef	70	9	1f6
10	19	7fff0	71	9	1f9
11	19	7fffc	72	10	3f4
12	19	7fffd	73	10	3f6
13	19	7fff	74	10	3f8
14	19	7fffe	75	11	7f5
15	19	7fff7	76	11	7f4
16	19	7fff8	77	11	7f6
17	19	7fffb	78	11	7f7
18	19	7fff9	79	12	ff5
19	18	3ffe4	80	12	ff8
20	19	7fffa	81	13	1ff4
21	18	3ffe3	82	13	1ff6
22	17	1ffef	83	13	1ff8
23	17	1fff0	84	14	3ff8
24	16	fff5	85	14	3ff4
25	17	1ffee	86	16	fff0
26	16	fff2	87	15	7ff4
27	16	fff3	88	16	fff6
28	16	fff4	89	15	7ff5
29	16	fff1	90	18	3ffe2
30	15	7ff6	91	19	7ffd9
31	15	7ff7	92	19	7ffda
32	14	3ff9	93	19	7ffdb
33	14	3ff5	94	19	7ffdc
34	14	3ff7	95	19	7ffdd
35	14	3ff3	96	19	7ffde
36	14	3ff6	97	19	7ffd8
37	14	3ff2	98	19	7ffd2
38	13	1ff7	99	19	7ffd3
39	13	1ff5	100	19	7ffd4
40	12	ff9	101	19	7ffd5
41	12	ff7	102	19	7ffd6
42	12	ff6	103	19	7fff2
43	11	7f9	104	19	7ffdf

44	12	ff4	105	19	7ffe7
45	11	7f8	106	19	7ffe8
46	10	3f9	107	19	7ffe9
47	10	3f7	108	19	7ffea
48	10	3f5	109	19	7ffeb
49	9	1f8	110	19	7ffe6
50	9	1f7	111	19	7ffe0
51	8	fa	112	19	7ffe1
52	8	f8	113	19	7ffe2
53	8	f6	114	19	7ffe3
54	7	79	115	19	7ffe4
55	6	3a	116	19	7ffe5
56	6	38	117	19	7ffd7
57	5	1a	118	19	7ffec
58	4	b	119	19	7ff4
59	3	4	120	19	7ff3
60	1	0			

Table A.2 — Spectrum Huffman Codebook 1

index	length	codeword (hexadecimal)	index	length	codeword (hexadecimal)
0	11	7f8	41	5	14
1	9	1f1	42	7	65
2	11	7fd	43	5	16
3	10	3f5	44	7	6d
4	7	68	45	9	1e9
5	10	3f0	46	7	63
6	11	7f7	47	9	1e4
7	9	1ec	48	7	6b
8	11	7f5	49	5	13
9	10	3f1	50	7	71
10	7	72	51	9	1e3
11	10	3f4	52	7	70
12	7	74	53	9	1f3
13	5	11	54	11	7fe
14	7	76	55	9	1e7
15	9	1eb	56	11	7f3
16	7	6c	57	9	1ef
17	10	3f6	58	7	60
18	11	7fc	59	9	1ee
19	9	1e1	60	11	7f0
20	11	7f1	61	9	1e2
21	9	1f0	62	11	7fa
22	7	61	63	10	3f3
23	9	1f6	64	7	6a
24	11	7f2	65	9	1e8
25	9	1ea	66	7	75
26	11	7fb	67	5	10
27	9	1f2	68	7	73
28	7	69	69	9	1f4
29	9	1ed	70	7	6e
30	7	77	71	10	3f7
31	5	17	72	11	7f6
32	7	6f	73	9	1e0

33	9	1e6	74	11	7f9
34	7	64	75	10	3f2
35	9	1e5	76	7	66
36	7	67	77	9	1f5
37	5	15	78	11	7ff
38	7	62	79	9	1f7
39	5	12	80	11	7f4
40	1	0			

Table A.3 — Spectrum Huffman Codebook 2

index	length	codeword (hexadecimal)	index	length	codeword (hexadecimal)
0	9	1f3	41	5	7
1	7	6f	42	6	1d
2	9	1fd	43	5	b
3	8	eb	44	6	30
4	6	23	45	8	ef
5	8	ea	46	6	1c
6	9	1f7	47	7	64
7	8	e8	48	6	1e
8	9	1fa	49	5	c
9	8	f2	50	6	29
10	6	2d	51	8	f3
11	7	70	52	6	2f
12	6	20	53	8	f0
13	5	6	54	9	1fc
14	6	2b	55	7	71
15	7	6e	56	9	1f2
16	6	28	57	8	f4
17	8	e9	58	6	21
18	9	1f9	59	8	e6
19	7	66	60	8	f7
20	8	f8	61	7	68
21	8	e7	62	9	1f8
22	6	1b	63	8	ee
23	8	f1	64	6	22
24	9	1f4	65	7	65
25	7	6b	66	6	31
26	9	1f5	67	4	2
27	8	ec	68	6	26
28	6	2a	69	8	ed
29	7	6c	70	6	25
30	6	2c	71	7	6a
31	5	a	72	9	1fb
32	6	27	73	7	72
33	7	67	74	9	1fe
34	6	1a	75	7	69
35	8	f5	76	6	2e
36	6	24	77	8	f6
37	5	8	78	9	1ff
38	6	1f	79	7	6d
39	5	9	80	9	1f6
40	3	0			

Table A.4 — Spectrum Huffman Codebook 3

index	length	codeword (hexadecimal)	index	length	codeword (hexadecimal)
0	1	0	41	10	3ef
1	4	9	42	9	1f3
2	8	ef	43	9	1f4
3	4	b	44	11	7f6
4	5	19	45	9	1e8
5	8	f0	46	10	3ea
6	9	1eb	47	13	1ffc
7	9	1e6	48	8	f2
8	10	3f2	49	9	1f1
9	4	a	50	12	ffb
10	6	35	51	10	3f5
11	9	1ef	52	11	7f3
12	6	34	53	12	ffc
13	6	37	54	8	ee
14	9	1e9	55	10	3f7
15	9	1ed	56	15	7ffe
16	9	1e7	57	9	1f0
17	10	3f3	58	11	7f5
18	9	1ee	59	15	7ffd
19	10	3ed	60	13	1ffb
20	13	1ffa	61	14	3ffa
21	9	1ec	62	16	fff
22	9	1f2	63	8	f1
23	11	7f9	64	10	3f0
24	11	7f8	65	14	3ffc
25	10	3f8	66	9	1ea
26	12	ff8	67	10	3ee
27	4	8	68	14	3ffb
28	6	38	69	12	ff6
29	10	3f6	70	12	ffa
30	6	36	71	15	7ffc
31	7	75	72	11	7f2
32	10	3f1	73	12	ff5
33	10	3eb	74	16	fffe
34	10	3ec	75	10	3f4
35	12	ff4	76	11	7f7
36	5	18	77	15	7ffb
37	7	76	78	12	ff7
38	11	7f4	79	12	ff9
39	6	39	80	15	7fa
40	7	74			

Table A.5 — Spectrum Huffman Codebook 4

index	length	codeword (hexadecimal)	index	length	codeword (hexadecimal)
0	4	7	41	7	6b
1	5	16	42	8	e3
2	8	f6	43	7	69
3	5	18	44	9	1f3
4	4	8	45	8	eb
5	8	ef	46	8	e6
6	9	1ef	47	10	3f6
7	8	f3	48	7	6e
8	11	7f8	49	7	6a
9	5	19	50	9	1f4
10	5	17	51	10	3ec
11	8	ed	52	9	1f0
12	5	15	53	10	3f9
13	4	1	54	8	f5
14	8	e2	55	8	ec
15	8	f0	56	11	7fb
16	7	70	57	8	ea
17	10	3f0	58	7	6f
18	9	1ee	59	10	3f7
19	8	f1	60	11	7f9
20	11	7fa	61	10	3f3
21	8	ee	62	12	fff
22	8	e4	63	8	e9
23	10	3f2	64	7	6d
24	11	7f6	65	10	3f8
25	10	3ef	66	7	6c
26	11	7fd	67	7	68
27	4	5	68	9	1f5
28	5	14	69	10	3ee
29	8	f2	70	9	1f2
30	4	9	71	11	7f4
31	4	4	72	11	7f7
32	8	e5	73	10	3f1
33	8	f4	74	12	ffe
34	8	e8	75	10	3ed
35	10	3f4	76	9	1f1
36	4	6	77	11	7f5
37	4	2	78	11	7fe
38	8	e7	79	10	3f5
39	4	3	80	11	7fc
40	4	0			

Table A.6 — Spectrum Huffman Codebook 5

index	length	codeword (hexadecimal)	index	length	codeword (hexadecimal)
0	13	1fff	41	4	a
1	12	ff7	42	7	71
2	11	7f4	43	8	f3
3	11	7e8	44	11	7e9
4	10	3f1	45	11	7ef
5	11	7ee	46	9	1ee
6	11	7f9	47	8	ef
7	12	ff8	48	5	18
8	13	1ffd	49	4	9
9	12	ffd	50	5	1b
10	11	7f1	51	8	eb
11	10	3e8	52	9	1e9
12	9	1e8	53	11	7ec
13	8	f0	54	11	7f6
14	9	1ec	55	10	3eb
15	10	3ee	56	9	1f3
16	11	7f2	57	8	ed
17	12	ffa	58	7	72
18	12	ff4	59	8	e9
19	10	3ef	60	9	1f1
20	9	1f2	61	10	3ed
21	8	e8	62	11	7f7
22	7	70	63	12	ff6
23	8	ec	64	11	7f0
24	9	1f0	65	10	3e9
25	10	3ea	66	9	1ed
26	11	7f3	67	8	f1
27	11	7eb	68	9	1ea
28	9	1eb	69	10	3ec
29	8	ea	70	11	7f8
30	5	1a	71	12	ff9
31	4	8	72	13	1ffc
32	5	19	73	12	ffc
33	8	ee	74	12	ff5
34	9	1ef	75	11	7ea
35	11	7ed	76	10	3f3
36	10	3f0	77	10	3f2
37	8	f2	78	11	7f5
38	7	73	79	12	ffb
39	4	b	80	13	1ffe
40	1	0			

Table A.7 — Spectrum Huffman Codebook 6

index	length	codeword (hexadecimal)	index	length	codeword (hexadecimal)
0	11	7fe	41	4	3
1	10	3fd	42	6	2f
2	9	1f1	43	7	73
3	9	1eb	44	9	1fa
4	9	1f4	45	9	1e7
5	9	1ea	46	7	6e
6	9	1f0	47	6	2b
7	10	3fc	48	4	7
8	11	7fd	49	4	1
9	10	3f6	50	4	5
10	9	1e5	51	6	2c
11	8	ea	52	7	6d
12	7	6c	53	9	1ec
13	7	71	54	9	1f9
14	7	68	55	8	ee
15	8	f0	56	6	30
16	9	1e6	57	6	24
17	10	3f7	58	6	2a
18	9	1f3	59	6	25
19	8	ef	60	6	33
20	6	32	61	8	ec
21	6	27	62	9	1f2
22	6	28	63	10	3f8
23	6	26	64	9	1e4
24	6	31	65	8	ed
25	8	eb	66	7	6a
26	9	1f7	67	7	70
27	9	1e8	68	7	69
28	7	6f	69	7	74
29	6	2e	70	8	f1
30	4	8	71	10	3fa
31	4	4	72	11	7ff
32	4	6	73	10	3f9
33	6	29	74	9	1f6
34	7	6b	75	9	1ed
35	9	1ee	76	9	1f8
36	9	1ef	77	9	1e9
37	7	72	78	9	1f5
38	6	2d	79	10	3fb
39	4	2	80	11	7fc
40	4	0			

Table A.8 — Spectrum Huffman Codebook 7

index	length	codeword (hexadecimal)	index	length	codeword (hexadecimal)
0	1	0	32	8	f3
1	3	5	33	8	ed
2	6	37	34	9	1e8
3	7	74	35	9	1ef
4	8	f2	36	10	3ef
5	9	1eb	37	10	3f1
6	10	3ed	38	10	3f9
7	11	7f7	39	11	7fb
8	3	4	40	9	1ed
9	4	c	41	8	ef
10	6	35	42	9	1ea
11	7	71	43	9	1f2
12	8	ec	44	10	3f3
13	8	ee	45	10	3f8
14	9	1ee	46	11	7f9
15	9	1f5	47	11	7fc
16	6	36	48	10	3ee
17	6	34	49	9	1ec
18	7	72	50	9	1f4
19	8	ea	51	10	3f4
20	8	f1	52	10	3f7
21	9	1e9	53	11	7f8
22	9	1f3	54	12	ffd
23	10	3f5	55	12	ffe
24	7	73	56	11	7f6
25	7	70	57	10	3f0
26	8	eb	58	10	3f2
27	8	f0	59	10	3f6
28	9	1f1	60	11	7fa
29	9	1f0	61	11	7fd
30	10	3ec	62	12	ffc
31	10	3fa	63	12	fff

Table A.9 — Spectrum Huffman Codebook 8

index	length	codeword (hexadecimal)	index	length	codeword (hexadecimal)
0	5	e	32	7	71
1	4	5	33	6	2b
2	5	10	34	6	2d
3	6	30	35	6	31
4	7	6f	36	7	6d
5	8	f1	37	7	70
6	9	1fa	38	8	f2
7	10	3fe	39	9	1f9
8	4	3	40	8	ef
9	3	0	41	7	68
10	4	4	42	6	33
11	5	12	43	7	6b
12	6	2c	44	7	6e
13	7	6a	45	8	ee
14	7	75	46	8	f9
15	8	f8	47	10	3fc
16	5	f	48	9	1f8
17	4	2	49	7	74
18	4	6	50	7	73
19	5	14	51	8	ed
20	6	2e	52	8	f0
21	7	69	53	8	f6
22	7	72	54	9	1f6
23	8	f5	55	9	1fd
24	6	2f	56	10	3fd
25	5	11	57	8	f3
26	5	13	58	8	f4
27	6	2a	59	8	f7
28	6	32	60	9	1f7
29	7	6c	61	9	1fb
30	8	ec	62	9	1fc
31	8	fa	63	10	3ff

Table A.10 — Spectrum Huffman Codebook 9

index	length	codeword (hexadecimal)	index	length	codeword (hexadecimal)
0	1	0	85	12	fda
1	3	5	86	12	fe3
2	6	37	87	12	fe9
3	8	e7	88	13	1fe6
4	9	1de	89	13	1ff3
5	10	3ce	90	13	1ff7
6	10	3d9	91	11	7d3
7	11	7c8	92	10	3d8
8	11	7cd	93	10	3e1
9	12	fc8	94	11	7d4
10	12	fdd	95	11	7d9
11	13	1fe4	96	12	fd3
12	13	1fec	97	12	fde
13	3	4	98	13	1fdd
14	4	c	99	13	1fd9
15	6	35	100	13	1fe2
16	7	72	101	13	1fea
17	8	ea	102	13	1ff1
18	8	ed	103	13	1ff6
19	9	1e2	104	11	7d2
20	10	3d1	105	10	3d4
21	10	3d3	106	10	3da
22	10	3e0	107	11	7c7
23	11	7d8	108	11	7d7
24	12	fcf	109	11	7e2
25	12	fd5	110	12	fce
26	6	36	111	12	fdb
27	6	34	112	13	1fd8
28	7	71	113	13	1fee
29	8	e8	114	14	3ff0
30	8	ec	115	13	1ff4
31	9	1e1	116	14	3ff2
32	10	3cf	117	11	7e1
33	10	3dd	118	10	3df
34	10	3db	119	11	7c9
35	11	7d0	120	11	7d6
36	12	fc7	121	12	fca
37	12	fd4	122	12	fd0
38	12	fe4	123	12	fe5
39	8	e6	124	12	fe6
40	7	70	125	13	1feb
41	8	e9	126	13	1fef
42	9	1dd	127	14	3ff3
43	9	1e3	128	14	3ff4
44	10	3d2	129	14	3ff5
45	10	3dc	130	12	fe0
46	11	7cc	131	11	7ce
47	11	7ca	132	11	7d5
48	11	7de	133	12	fc6
49	12	fd8	134	12	fd1
50	12	fea	135	12	fe1
51	13	1fdb	136	13	1fe0
52	9	1df	137	13	1fe8

53	8	eb	138	13	1ff0
54	9	1dc	139	14	3ff1
55	9	1e6	140	14	3ff8
56	10	3d5	141	14	3ff6
57	10	3de	142	15	7ffc
58	11	7cb	143	12	fe8
59	11	7dd	144	11	7df
60	11	7dc	145	12	fc9
61	12	fcd	146	12	fd7
62	12	fe2	147	12	fdc
63	12	fe7	148	13	1fdc
64	13	1fe1	149	13	1fdf
65	10	3d0	150	13	1fed
66	9	1e0	151	13	1ff5
67	9	1e4	152	14	3ff9
68	10	3d6	153	14	3ffb
69	11	7c5	154	15	7ffd
70	11	7d1	155	15	7ffe
71	11	7db	156	13	1fe7
72	12	fd2	157	12	fcc
73	11	7e0	158	12	fd6
74	12	fd9	159	12	fdf
75	12	feb	160	13	1fde
76	13	1fe3	161	13	1fda
77	13	1fe9	162	13	1fe5
78	11	7c4	163	13	1ff2
79	9	1e5	164	14	3ffa
80	10	3d7	165	14	3ff7
81	11	7c6	166	14	3ffc
82	11	7cf	167	14	3ffd
83	11	7da	168	15	7fff
84	12	fc9			

Table A.11 — Spectrum Huffman Codebook 10

index	length	codeword (hexadecimal)	index	length	codeword (hexadecimal)
0	6	22	85	9	1c7
1	5	8	86	9	1ca
2	6	1d	87	9	1e0
3	6	26	88	10	3db
4	7	5f	89	10	3e8
5	8	d3	90	11	7ec
6	9	1cf	91	9	1e3
7	10	3d0	92	8	d2
8	10	3d7	93	8	cb
9	10	3ed	94	8	d0
10	11	7f0	95	8	d7
11	11	7f6	96	8	db
12	12	ffd	97	9	1c6
13	5	7	98	9	1d5
14	4	0	99	9	1d8
15	4	1	100	10	3ca
16	5	9	101	10	3da
17	6	20	102	11	7ea
18	7	54	103	11	7f1
19	7	60	104	9	1e1
20	8	d5	105	8	d4
21	8	dc	106	8	cf
22	9	1d4	107	8	d6
23	10	3cd	108	8	de
24	10	3de	109	8	e1
25	11	7e7	110	9	1d0
26	6	1c	111	9	1d6
27	4	2	112	10	3d1
28	5	6	113	10	3d5
29	5	c	114	10	3f2
30	6	1e	115	11	7ee
31	6	28	116	11	7fb
32	7	5b	117	10	3e9
33	8	cd	118	9	1cd
34	8	d9	119	9	1c8
35	9	1ce	120	9	1cb
36	9	1dc	121	9	1d1
37	10	3d9	122	9	1d7
38	10	3f1	123	9	1df
39	6	25	124	10	3cf
40	5	b	125	10	3e0
41	5	a	126	10	3ef
42	5	d	127	11	7e6
43	6	24	128	11	7f8
44	7	57	129	12	ffa
45	7	61	130	10	3eb
46	8	cc	131	9	1dd
47	8	dd	132	9	1d3
48	9	1cc	133	9	1d9
49	9	1de	134	9	1db
50	10	3d3	135	10	3d2
51	10	3e7	136	10	3cc
52	7	5d	137	10	3dc

53	6	21	138	10	3ea
54	6	1f	139	11	7ed
55	6	23	140	11	7f3
56	6	27	141	11	7f9
57	7	59	142	12	ff9
58	7	64	143	11	7f2
59	8	d8	144	10	3ce
60	8	df	145	9	1e4
61	9	1d2	146	10	3cb
62	9	1e2	147	10	3d8
63	10	3dd	148	10	3d6
64	10	3ee	149	10	3e2
65	8	d1	150	10	3e5
66	7	55	151	11	7e8
67	6	29	152	11	7f4
68	7	56	153	11	7f5
69	7	58	154	11	7f7
70	7	62	155	12	ffb
71	8	ce	156	11	7fa
72	8	e0	157	10	3ec
73	8	e2	158	10	3df
74	9	1da	159	10	3e1
75	10	3d4	160	10	3e4
76	10	3e3	161	10	3e6
77	11	7eb	162	10	3f0
78	9	1c9	163	11	7e9
79	7	5e	164	11	7ef
80	7	5a	165	12	ff8
81	7	5c	166	12	ffe
82	7	63	167	12	ffc
83	8	ca	168	12	fff
84	8	da			

Table A.12 — Spectrum Huffman Codebook 11

index	length	codeword (hexadecimal)	index	length	codeword (hexadecimal)
0	4	0	145	10	38d
1	5	6	146	10	398
2	6	19	147	10	3b7
3	7	3d	148	10	3d3
4	8	9c	149	10	3d1
5	8	c6	150	10	3db
6	9	1a7	151	11	7dd
7	10	390	152	8	b4
8	10	3c2	153	10	3de
9	10	3df	154	9	1a9
10	11	7e6	155	9	19b
11	11	7f3	156	9	19c
12	12	ffb	157	9	1a1
13	11	7ec	158	9	1aa
14	12	ffa	159	9	1ad
15	12	ffe	160	9	1b3
16	10	38e	161	10	38b
17	5	5	162	10	3b2
18	4	1	163	10	3b8
19	5	8	164	10	3ce
20	6	14	165	10	3e1
21	7	37	166	10	3e0
22	7	42	167	11	7d2
23	8	92	168	11	7e5
24	8	af	169	8	b7
25	9	191	170	11	7e3
26	9	1a5	171	9	1bb
27	9	1b5	172	9	1a8
28	10	39e	173	9	1a6
29	10	3c0	174	9	1b0
30	10	3a2	175	9	1b2
31	10	3cd	176	9	1b7
32	11	7d6	177	10	39b
33	8	ae	178	10	39a
34	6	17	179	10	3ba
35	5	7	180	10	3b5
36	5	9	181	10	3d6
37	6	18	182	11	7d7
38	7	39	183	10	3e4
39	7	40	184	11	7d8
40	8	8e	185	11	7ea
41	8	a3	186	8	ba
42	8	b8	187	11	7e8
43	9	199	188	10	3a0
44	9	1ac	189	9	1bd
45	9	1c1	190	9	1b4
46	10	3b1	191	10	38a
47	10	396	192	9	1c4
48	10	3be	193	10	392
49	10	3ca	194	10	3aa
50	8	9d	195	10	3b0
51	7	3c	196	10	3bc
52	6	15	197	10	3d7

53	6	16	198	11	7d4
54	6	1a	199	11	7dc
55	7	3b	200	11	7db
56	7	44	201	11	7d5
57	8	91	202	11	7f0
58	8	a5	203	8	c1
59	8	be	204	11	7fb
60	9	196	205	10	3c8
61	9	1ae	206	10	3a3
62	9	1b9	207	10	395
63	10	3a1	208	10	39d
64	10	391	209	10	3ac
65	10	3a5	210	10	3ae
66	10	3d5	211	10	3c5
67	8	94	212	10	3d8
68	8	9a	213	10	3e2
69	7	36	214	10	3e6
70	7	38	215	11	7e4
71	7	3a	216	11	7e7
72	7	41	217	11	7e0
73	8	8c	218	11	7e9
74	8	9b	219	11	7f7
75	8	b0	220	9	190
76	8	c3	221	11	7f2
77	9	19e	222	10	393
78	9	1ab	223	9	1be
79	9	1bc	224	9	1c0
80	10	39f	225	10	394
81	10	38f	226	10	397
82	10	3a9	227	10	3ad
83	10	3cf	228	10	3c3
84	8	93	229	10	3c1
85	8	bf	230	10	3d2
86	7	3e	231	11	7da
87	7	3f	232	11	7d9
88	7	43	233	11	7df
89	7	45	234	11	7eb
90	8	9e	235	11	7f4
91	8	a7	236	11	7fa
92	8	b9	237	9	195
93	9	194	238	11	7f8
94	9	1a2	239	10	3bd
95	9	1ba	240	10	39c
96	9	1c3	241	10	3ab
97	10	3a6	242	10	3a8
98	10	3a7	243	10	3b3
99	10	3bb	244	10	3b9
100	10	3d4	245	10	3d0
101	8	9f	246	10	3e3
102	9	1a0	247	10	3e5
103	8	8f	248	11	7e2
104	8	8d	249	11	7de
105	8	90	250	11	7ed
106	8	98	251	11	7f1
107	8	a6	252	11	7f9
108	8	b6	253	11	7fc

109	8	c4	254	9	193
110	9	19f	255	12	ffd
111	9	1af	256	10	3dc
112	9	1bf	257	10	3b6
113	10	399	258	10	3c7
114	10	3bf	259	10	3cc
115	10	3b4	260	10	3cb
116	10	3c9	261	10	3d9
117	10	3e7	262	10	3da
118	8	a8	263	11	7d3
119	9	1b6	264	11	7e1
120	8	ab	265	11	7ee
121	8	a4	266	11	7ef
122	8	aa	267	11	7f5
123	8	b2	268	11	7f6
124	8	c2	269	12	ffc
125	8	c5	270	12	fff
126	9	198	271	9	19d
127	9	1a4	272	9	1c2
128	9	1b8	273	8	b5
129	10	38c	274	8	a1
130	10	3a4	275	8	96
131	10	3c4	276	8	97
132	10	3c6	277	8	95
133	10	3dd	278	8	99
134	10	3e8	279	8	a0
135	8	ad	280	8	a2
136	10	3af	281	8	ac
137	9	192	282	8	a9
138	8	bd	283	8	b1
139	8	bc	284	8	b3
140	9	18e	285	8	bb
141	9	197	286	8	c0
142	9	19a	287	9	18f
143	9	1a3	288	5	4
144	9	1b1			

Table A.13 — Kaiser-Bessel window for SSR profile EIGHT_SHORT_SEQUENCE

i	w(i)	i	w(i)
0	0.0000875914060105	16	0.7446454751465113
1	0.0009321760265333	17	0.8121892962974020
2	0.0032114611466596	18	0.8683559394406505
3	0.0081009893216786	19	0.9125649996381605
4	0.0171240286619181	20	0.9453396205809574
5	0.0320720743527833	21	0.9680864942677585
6	0.0548307856028528	22	0.9827581789763112
7	0.0871361822564870	23	0.9914756203467121
8	0.1302923415174603	24	0.9961964092194694
9	0.1848955425508276	25	0.9984956609571091
10	0.2506163195331889	26	0.9994855586984285
11	0.3260874142923209	27	0.9998533730714648
12	0.4089316830907141	28	0.9999671864476404
13	0.4959414909423747	29	0.9999948432453556
14	0.5833939894958904	30	0.9999995655238333
15	0.6674601983218376	31	0.9999999961638728

Table A.14 — Kaiser-Bessel window for SSR profile for other window sequences.

i	w(i)	i	w(i)
0	0.0005851230124487	128	0.7110428359000029
1	0.0009642149851497	129	0.7188474364707993
2	0.0013558207534965	130	0.7265597347077880
3	0.0017771849644394	131	0.7341770687621900
4	0.0022352533849672	132	0.7416968783634273
5	0.0027342299070304	133	0.7491167073477523
6	0.0032773001022195	134	0.7564342060337386
7	0.0038671998069216	135	0.7636471334404891
8	0.0045064443384152	136	0.7707533593446514
9	0.0051974336885144	137	0.7777508661725849
10	0.0059425050016407	138	0.7846377507242818
11	0.0067439602523141	139	0.7914122257259034
12	0.0076040812644888	140	0.7980726212080798
13	0.0085251378135895	141	0.8046173857073919
14	0.0095093917383048	142	0.8110450872887550
15	0.0105590986429280	143	0.8173544143867162
16	0.0116765080854300	144	0.8235441764639875
17	0.0128638627792770	145	0.8296133044858474
18	0.0141233971318631	146	0.8355608512093652
19	0.0154573353235409	147	0.8413859912867303
20	0.0168678890600951	148	0.8470880211822968
21	0.0183572550877256	149	0.8526663589032990
22	0.0199276125319803	150	0.8581205435445334
23	0.0215811201042484	151	0.8634502346476508
24	0.0233199132076965	152	0.8686552113760616
25	0.0251461009666641	153	0.8737353715068081
26	0.0270617631981826	154	0.8786907302411250
27	0.0290689473405856	155	0.8835214188357692
28	0.0311696653515848	156	0.8882276830575707
29	0.0333658905863535	157	0.8928098814640207
30	0.0356595546648444	158	0.8972684835130879
31	0.0380525443366107	159	0.9016040675058185
32	0.0405466983507029	160	0.9058173183656508
33	0.0431438043376910	161	0.9099090252587376
34	0.0458455957104702	162	0.9138800790599416
35	0.0486537485902075	163	0.9177314696695282

36	0.0515698787635492	164	0.9214642831859411
37	0.0545955386770205	165	0.9250796989403991
38	0.0577322144743916	166	0.9285789863994010
39	0.0609813230826460	167	0.9319635019415643
40	0.0643442093520723	168	0.9352346855155568
41	0.0678221432558827	169	0.9383940571861993
42	0.0714163171546603	170	0.9414432135761304
43	0.0751278431308314	171	0.9443838242107182
44	0.0789577503982528	172	0.9472176277741918
45	0.0829069827918993	173	0.9499464282852282
46	0.0869763963425241	174	0.9525720912004834
47	0.0911667569410503	175	0.9550965394547873
48	0.0954787380973307	176	0.9575217494469370
49	0.0999129187977865	177	0.9598497469802043
50	0.1044697814663005	178	0.9620826031668507
51	0.1091497100326053	179	0.9642224303060783
52	0.1139529881122542	180	0.9662713777449607
53	0.1188797973021148	181	0.9682316277319895
54	0.1239302155951605	182	0.9701053912729269
55	0.1291042159181728	183	0.9718949039986892
56	0.1344016647957880	184	0.9736024220549734
57	0.1398223211441467	185	0.9752302180233160
58	0.1453658351972151	186	0.9767805768831932
59	0.1510317475686540	187	0.9782557920246753
60	0.1568194884519144	188	0.9796581613210076
61	0.1627283769610327	189	0.9809899832703159
62	0.1687576206143887	190	0.9822535532154261
63	0.1749063149634756	191	0.9834511596505429
64	0.1811734433685097	192	0.9845850806232530
65	0.1875578769224857	193	0.9856575802399989
66	0.1940583745250518	194	0.9866709052828243
67	0.2006735831073503	195	0.9876272819448033
68	0.2074020380087318	196	0.9885289126911557
69	0.2142421635060113	197	0.9893779732525968
70	0.2211922734956977	198	0.9901766097569984
71	0.2282505723293797	199	0.9909269360049311
72	0.2354151558022098	200	0.9916310308941294
73	0.2426840122941792	201	0.9922909359973702
74	0.2500550240636293	202	0.9929086532976777
75	0.2575259686921987	203	0.9934861430841844
76	0.2650945206801527	204	0.9940253220113651
77	0.2727582531907993	205	0.9945280613237534
78	0.2805146399424422	206	0.9949961852476154
79	0.2883610572460804	207	0.9954314695504363
80	0.2962947861868143	208	0.9958356402684387
81	0.3043130149466800	209	0.9962103726017252
82	0.3124128412663888	210	0.9965572899760172
83	0.3205912750432127	211	0.9968779632693499
84	0.3288452410620226	212	0.9971739102014799
85	0.3371715818562547	213	0.9974465948831872
86	0.3455670606953511	214	0.9976974275220812
87	0.3540283646950029	215	0.9979277642809907
88	0.3625521080463003	216	0.9981389072844972
89	0.3711348353596863	217	0.9983321047686901
90	0.3797730251194006	218	0.9985085513687731
91	0.3884630932439016	219	0.9986693885387259
92	0.3972013967475546	220	0.9988157050968516
93	0.4059842374986933	221	0.9989485378906924
94	0.4148078660689724	222	0.9990688725744943
95	0.4236684856687616	223	0.9991776444921379

96	0.4325622561631607	224	0.9992757396582338
97	0.4414852981630577	225	0.9993639958299003
98	0.4504336971855032	226	0.9994432036616085
99	0.4594035078775303	227	0.9995141079353859
100	0.4683907582974173	228	0.9995774088586188
101	0.4773914542472655	229	0.9996337634216871
102	0.4864015836506502	230	0.9996837868076957
103	0.4954171209689973	231	0.9997280538466377
104	0.5044340316502417	232	0.9997671005064359
105	0.5134482766032377	233	0.9998014254134544
106	0.5224558166913167	234	0.9998314913952471
107	0.5314526172383208	235	0.9998577270385304
108	0.5404346525403849	236	0.9998805282555989
109	0.5493979103766972	237	0.9999002598526793
110	0.5583383965124314	238	0.9999172570940037
111	0.5672521391870222	239	0.9999318272557038
112	0.5761351935809411	240	0.9999442511639580
113	0.5849836462541291	241	0.9999547847121726
114	0.5937936195492526	242	0.9999636603523446
115	0.6025612759529649	243	0.9999710885561258
116	0.6112828224083939	244	0.9999772592414866
117	0.6199545145721097	245	0.9999823431612708
118	0.6285726610088878	246	0.9999864932503106
119	0.6371336273176413	247	0.9999898459281599
120	0.6456338401819751	248	0.9999925223548691
121	0.6540697913388968	249	0.9999946296375997
122	0.6624380414593221	250	0.9999962619864214
123	0.6707352239341151	251	0.9999975018180320
124	0.6789580485595255	252	0.9999984208055542
125	0.6871033051160131	253	0.9999990808746198
126	0.6951678668345944	254	0.9999995351446231
127	0.7031486937449871	255	0.9999998288155155

Annex B (informative)

Information on Unused Codebooks

As specified by the normative part of this standard, the AAC decoder does not make use of codebooks #12 and #13. However, if desired, a decoder may use these codebooks to extend its functionality in a way that is consistent with other MPEG standards like ISO/IEC 14496-3 which use these particular codebooks to indicate coding by extended coding methods.

As an example, the syntax in subclause 6.3 would change to

Table B.1 — Extended syntax for scale_factor_data()

Syntax	No. Of bits	Mnemonic
<pre> scale_factor_data() { noise_pcm_flag = 1; for (g = 0; g < num_window_groups; g++) { for (sfb = 0; sfb < max_sfb; sfb++) { if (sfb_cb[g][sfb] != ZERO_HCB) { if (is_intensity(g,sfb)) hcod_sf[dpcm_is_position[g][sfb]]; else if (sfb_cb[g][sfb] == 13) if (noise_pcm_flag) { noise_pcm_flag = 0; dpcm_noise_nrg[g][sfb]; } else hcod_sf[dpcm_noise_nrg[g][sfb]]; else hcod_sf[dpcm_sf[g][sfb]]; } } } } </pre>	<p>1..19</p> <p>9</p> <p>1..19</p> <p>1..19</p>	<p>vlclbf</p> <p>uimsbf</p> <p>vlclbf</p> <p>vlclbf</p>

Annex C (informative)

Encoder

C.1 Psychoacoustic Model

C.1.1 General

This annex presents the general Psychoacoustic Model for the AAC encoder. The psychoacoustic model calculates the maximum distortion energy which is masked by the signal energy. This energy is called *threshold*. The threshold generation process has three inputs. They are:

1. The shift length for the threshold calculation process is called *iblen*. This *iblen* must remain constant over any particular application of the threshold calculation process. Since it is necessary to calculate thresholds for two different shift lengths, two processes, each running with a fixed shift length, are necessary. For long FFT *iblen* = 1024, for short FFT *iblen* = 128.
2. For each FFT type the newest *iblen* samples of the signal, with the samples delayed (either in the filterbank or psychoacoustic calculation) such that the window of the psychoacoustic calculation is centered in the time-window of the codec time/frequency transform .
3. The sampling rate. There are sets of tables provided for the standard sampling rates. Sampling rate, just as *iblen*, must necessarily remain constant over one implementation of the threshold calculation process.

The output from the psychoacoustic model is:

1. a set of Signal-to-Mask Ratios and thresholds, which are adapted to the encoder as described below,
2. the delayed time domain data (PCM samples) , which are used by the MDCT,
3. the block type for the MDCT (long, start, stop or short type)
4. an estimation of how many bits should be used for encoding in addition to the average available bits.

The delay of the PCM samples is necessary , because if the switch decision algorithm detects an attack, so that *short blocks* have to be used for the actual frame, the *long block* before the *short blocks* has to be 'patched' to a *start block type* in this case..

Before running the model initially, the array used to hold the preceding FFT source data window and the arrays used to hold $r(w)$ and $f(w)$ should be zeroed to provide a known starting point.

C.1.2 Comments on Notation

Throughout this threshold calculation process, three indices for data values are used. These are:

- w*- indicates that the calculation is indexed by frequency in the FFT spectral line domain. An index of 0 corresponds to the DC term and an index of 1023 corresponds to the spectral line at the Nyquist frequency.
- b* - indicates that the calculation is indexed in the threshold calculation partition domain. In the case where the calculation includes a convolution or sum in the threshold calculation partition domain, *bb* will be used as the summation variable. Partition numbering starts at 0.
- n* - indicates that the calculation is indexed in the coder scalefactor band domain. An index of 0 corresponds to the lowest scalefactor band.

C.1.3 The "Spreading Function"

Several points in the following description refer to the "spreading function". It is calculated by the following method:

```

if j >= i
    tmpx = 3.0 (j-i)
else
    tmpx = 1.5 (j-i)

```

Where i is the Bark value of the signal being spread, j is the Bark value of the band being spread into, and $tmpx$ is a temporary variable.

```

tmpz = 8 * minimum ((tmpx-0.5)2-2 (tmpx-0.5), 0)

```

Where $tmpz$ is a temporary variable, and $\text{minimum}(a, b)$ is a function returning the more negative of a or b .

```

tmpy = 15.811389 + 7.5 (tmpx + 0.474) - 17.5 (1.0 + (tmpx + 0.474)2)0.5

```

where $tmpy$ is another temporary variable.

```

if (tmpy < -100) then {sprdngf(i, j) = 0} else {sprdngf(i, j) = 10^((tmpz + tmpy)/10)}

```

C.1.4 Steps in Threshold Calculation

The following are the necessary steps for the calculation of $SMR(n)$ and $xmin(n)$ used in the coder for long and short FFT.

1. Reconstruct $2 * iblen$ samples of the input signal.

$iblen$ new samples are made available at every call to the threshold generator. The threshold generator must store $2 * iblen - iblen$ samples, and concatenate those samples to accurately reconstruct $2 * iblen$ consecutive samples of the input signal, $s(i)$, where i represents the index, $0 \leq i < 2 * iblen$, of the current input stream.

2. Calculate the complex spectrum of the input signal.

First, $s(i)$ is windowed by a Hann window, i.e.

```

sw(i) = s(i) * (0.5 - 0.5 * cos((pi * (i+0.5)) / iblen)).

```

Second, a standard forward FFT of $sw(i)$ is calculated. Third, the polar representation of the transform is calculated. $r(w)$ and $f(w)$ represent the magnitude and phase components of the transformed $sw(i)$, respectively.

3. Calculate a predicted $r(w)$ and $f(w)$.

A predicted magnitude, $r_pred(w)$ and phase, $f_pred(w)$ are calculated from the preceding two threshold calculation blocks $r(w)$ and $f(w)$:

```

r_pred(w) = 2.0 * r(t-1) - r(t-2)

```

```

f_pred(w) = 2.0 * f(t-1) - f(t-2)

```

where t represents the current block number, $t-1$ indexes the previous block's data, and $t-2$ indexes the data from the threshold calculation block before that.

4. Calculate the unpredictability measure $c(w)$.

```

c(w) = (((r(w) * cos(f(w)) - r_pred(w) * cos(f_pred(w)))2 + (r(w) *
sin(f(w)) - r_pred(w)
* sin(f_pred(w)))2)0.5) / (r(w) + abs(r_pred(w)))

```

This formula is used for each of the short blocks with the short FFT, for long blocks for the first 6 lines the unpredictability measure is calculated from the long FFT, for the remaining lines the minimum of the

unpredictability of all short FFT's is used. If calculation power should be saved, the unpredictability of the upper part of the spectrum can be set to 0.4.

5. Calculate the energy and unpredictability in the threshold calculation partitions.

The energy in each partition, $e(b)$, is:

```
do for each partition b:
  e(b) = 0
  do from lower index to upper index w of partition b
    e(b) = e(b) + r(w)^2
  end do
end do
```

($e(b)$ is used in the M/S-module (see subclause C.6.1): $e(b)$ is equal to Xengy with 'X' = [R,L,M,S]) and the weighted unpredictability, $c(b)$, is:

```
do for each partition b:
  c(b) = 0
  do from lower index to upper index w of partition b
    c(b) = c(b) + r(w)^2 * c(w)
  end do
end do
```

The threshold calculation partitions provide a resolution of approximately either one FFT line or 1/3 critical band, whichever is wider. At low frequencies, a single line of the FFT will constitute a calculation partition. At high frequencies, many lines will be combined into one calculation partition. A set of partition values is provided for each of the three sampling rates in Table C.1 to Table C.24. These Table elements will be used in the threshold calculation process. There are several elements in each Table entry:

- 1) The index of the calculation partition, b .
- 2) The lowest frequency line in the partition, $w_{low}(b)$.
- 3) The highest frequency line in the partition, $w_{high}(b)$
- 4) The median bark value of the partition, $bval(b)$
- 5) The threshold in quiet $qsthr(b)$
- 6) A largest value of b , $bmax$, equal to the largest index, exists for each sampling rate.

6. Convolve the partitioned energy and unpredictability with the spreading function.

```
for each partition b:
  ecb(b) = 0
  do for each partition bb:
    ecb(b) = ecb(b) + e(bb) * sprdngf(bval(bb), bval(b))
  end do
end do
do for each partition b:
  ct(b) = 0
  do for each partition bb:
    ct(b) = ct(b) + c(bb) * sprdngf(bval(bb), bval(b))
  end do
end do
```

Because $ct(b)$ is weighted by the signal energy, it must be renormalized to $cb(b)$

$$cb(b) = ct(b) / ecb(b)$$

Just as this, due to the non-normalized nature of the spreading function, ecb_b should be renormalized and the normalized energy en_b , calculated.

$$en(b) = ecb(b) * rnorm(b)$$

The normalization coefficient, $rnorm(b)$, is:

```
do for each partition b
  tmp(b) = 0
  do for each partition bb
    tmp(b) = tmp(b) + sprdngf(bval(bb), bval(b))
  end do
  rnorm(b) = 1/ tmp(b)
end do
```

7. Convert $cb(b)$ to $tb(b)$, the tonality index.

$$tb(b) = -0.299 - 0.43 \log_e (cb(b))$$

Each $tb(b)$ is limited to the range of $0 < tb(b) < 1$.

8. Calculate the required SNR in each partition.

$NMT(b) = 6$ dB for all b . $NMT(b)$ is the value for noise masking tone (in dB) for the partition. $TMN(b) = 18$ dB for all b . $TMN(b)$ is the value for tone masking noise (in dB). The required signal to noise ratio, $SNR(b)$, is:

$$SNR(b) = tb(b) * TMN(b) + (1-tb(b)) * NMT(b)$$

9. Calculate the power ratio.

The power ratio, $bc(b)$, is:

$$bc(b) = 10^{(-SNR(b) / 10)}$$

10. Calculation of actual energy threshold, $nb(b)$.

$$nb(b) = en(b) * bc(b)$$

$nb(b)$ is also used in the M/S-module (see clause 12): $nb(b)$ is equal to X_{thr} with 'X'=[R,L,M,S]

11. Pre-echo control and threshold in quiet.

To avoid pre-echoes the pre-echo control is calculated for short and long FFT, the threshold in quiet is also considered here:

$nb_l(b)$ is the threshold of partition b for the last block, $qsthr(b)$ is the threshold in quiet. The dB values of $qsthr(b)$ shown in Figure C.1

Table C.1 to Table C.24 are relative to the level that a sine wave of + or - $\frac{1}{2}$ lsb has in the FFT used for threshold calculation. The dB values must be converted into the energy domain after considering the FFT normalization actually used.

$$nb(b) = \max (qsthr(b), \min (nb(b), nb_l(b) * rpelev))$$

$rpelev$ is set to '1' for short blocks and '2' for long blocks

12. The PE is calculated for each block type from the ratio $e(b) / nb(b)$, where $nb(b)$ is the threshold and $e(b)$ is the energy for each threshold partition.

```
PE = 0
do for threshold partition b
  PE = PE - ( w_high(b) - w_low(b) ) * log10 ( nb(b) / ( e(b) + 1 ) )
end do
```

13. The decision, whether long or short block type is used for encoding is made according to this pseudo code.

```

if PE for long block is greater than switch_pe then
  coding_block_type = short_block_type
else
  coding_block_type = long_block_type
end if
if (coding_block_type == short_block_type) and
  (last_coding_block_type == long_type) then
  last coding block type = start_type
else
  last_coding_block_type = short_type

```

The last four lines are necessary since there is no combined stop/start block type in AAC. *switch_pe* is a implementation dependend constant

14. Calculate the signal-to-mask ratios, $SMR(n)$ and the codec threshold $xmin(n)$.

Table 45 to Table 57 shows:

1. The index, *swb*, of the coder partition called scalefactor band.
2. The offset of mdct line for the scalefactor band *swb_offset_long/short_window*.

we define the following variable :

```

n = swb
w_low(n) = swb_offset_long/short_window(n)
w_high(n) = swb_offset_long/short_window(n+1) - 1

```

The FFT energy in the scalefactor band, $epart(n)$, is:

```

do for each scalefactor band n
  epart(n) = 0
  do for w = lower index w_low(n) to n = upper index w_high(n)
    epart(n) = epart(n) + r(w)^2
  end do
end do

```

the threshold for one line of the spectrum is calculated according to:

```

do for each threshold partition b
  thr(all line_indices in this partition b) =
    thr(w_low(b), ..., w_high(b)) = nb(b) / (w_high(b)+1-w_low(b))
end do

```

the noise level in the scalefactor band on FFT level, $npart(n)$ is calculated as:

```

do for each scalefactor band n
  npart(n) = minimum( thr(w_low(n)), ..., thr(w_high(n)) )
    * (w_high(n)+1-w_low(n))
end do

```

Where, in this case, minimum (a,...,z) is a function returning the smallest positive argument of the arguments a...z.

The ratios to be sent to the quantization module, $SMR(n)$, are calculated as:

$$SMR(n) = epart(n) / npart(n)$$

For the calculation of coder thresholds $xmin(n)$ the MDCT energy for each scalefactor band is calculated:

```

do for all scalefactor bands n
  codec_e(n) = 0
  do for lower index i to higher index i of this scalefactor band
    codec_e(n) = codec_e(n) + (mdct_line(i))^2
  end do
end do

```

Then $xmin(n)$, the maximum allowed error energy on MDCT level, can be calculated according to this formula:

$$xmin(n) = npart(n) * codec_e(n) / epart(n)$$

15. Calculate the bit allocation out of the psychoacoustic entropy (PE).

$$bit_allocation = pew1 * PE + pew2 * sqrt(PE);$$

for long blocks the constants are defined as:

$$pew1 = 0.3, \quad pew2 = 6.0$$

for short blocks the PE of the eight short blocks is summed up and the constants are :

$$pew1 = 0.6, \quad pew2 = 24$$

then $bit_allocation$ is limited to $0 < bit_allocation < 3000$ and $more_bits$ is calculated :

$$more_bits = bit_allocation - (mean_bits - side_info_bits)$$

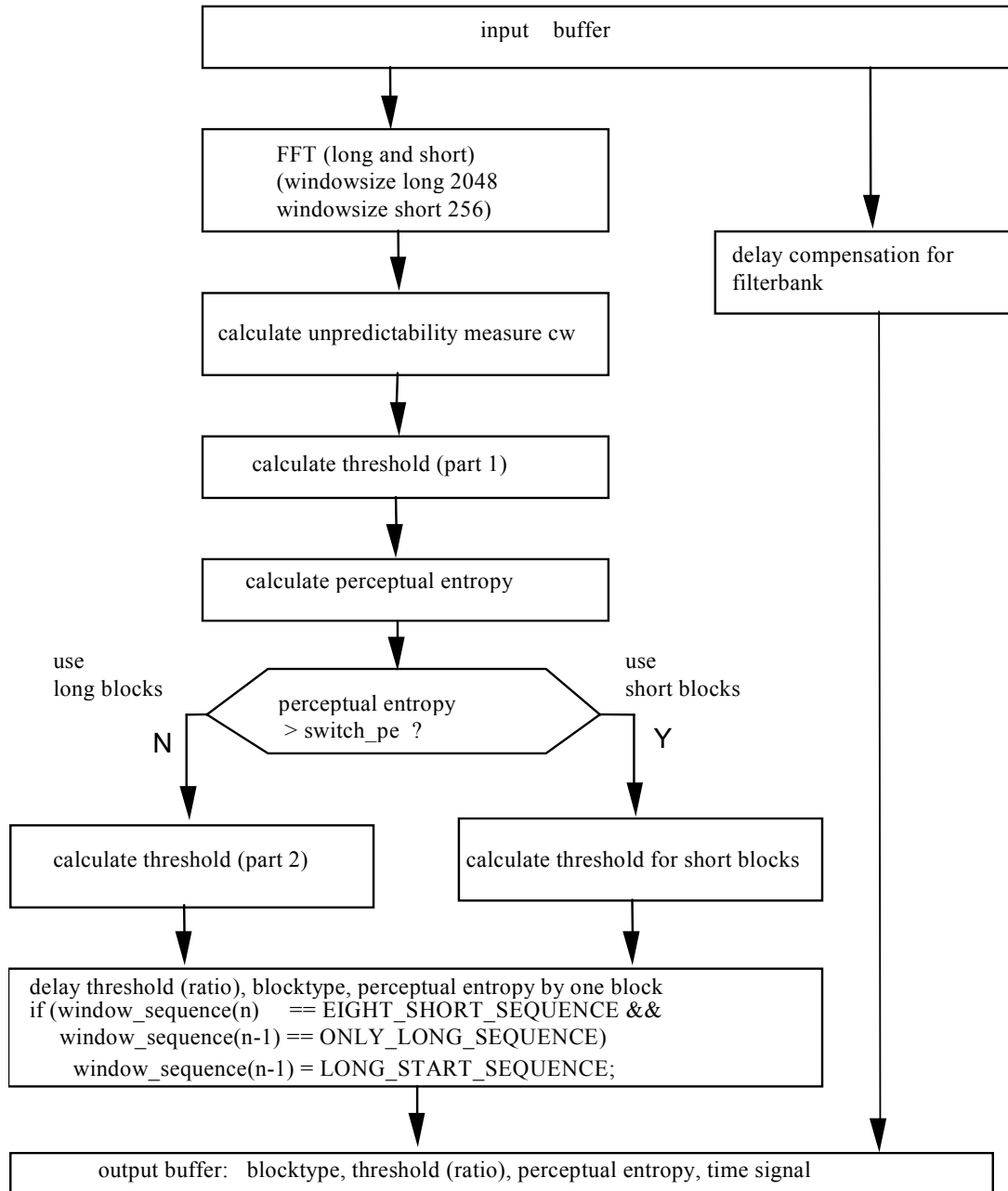

Figure C.1 — Block diagram psychoacoustic model

Table C.1 — Psychoacoustic parameters for 8 kHz long FFT

index	w_low	w_high	width	bval	qsthr
0	0	8	9	0.18	46.82
1	9	17	9	0.53	46.82
2	18	26	9	0.89	46.82
3	27	35	9	1.24	41.82
4	36	44	9	1.59	41.82
5	45	53	9	1.94	41.82
6	54	62	9	2.29	38.82
7	63	71	9	2.63	38.82
8	72	80	9	2.98	38.82
9	81	89	9	3.31	33.82
10	90	98	9	3.65	33.82
11	99	108	10	3.99	34.28
12	109	118	10	4.35	32.28
13	119	128	10	4.71	32.28
14	129	138	10	5.05	32.28
15	139	148	10	5.39	32.28
16	149	159	11	5.74	32.69
17	160	170	11	6.10	32.69
18	171	181	11	6.45	32.69
19	182	192	11	6.79	32.69
20	193	204	12	7.13	33.07
21	205	216	12	7.48	33.07
22	217	228	12	7.82	33.07
23	229	241	13	8.17	33.42
24	242	254	13	8.51	33.42
25	255	268	14	8.85	33.74
26	269	282	14	9.20	33.74
27	283	297	15	9.54	34.04
28	298	312	15	9.88	34.04
29	313	328	16	10.22	34.32
30	329	345	17	10.56	34.58
31	346	363	18	10.91	34.83
32	364	381	18	11.25	34.83
33	382	400	19	11.58	35.06
34	401	420	20	11.91	35.29
35	421	441	21	12.24	35.50
36	442	464	23	12.58	35.89
37	465	488	24	12.92	36.08
38	489	514	26	13.26	36.43
39	515	541	27	13.59	36.59
40	542	570	29	13.93	36.90
41	571	601	31	14.26	37.19
42	602	634	33	14.60	37.46
43	635	670	36	14.93	37.84
44	671	708	38	15.27	38.07
45	709	749	41	15.60	38.40
46	750	793	44	15.93	38.71
47	794	841	48	16.26	39.09
48	842	893	52	16.60	39.44
49	894	949	56	16.93	39.76
50	950	1009	60	17.26	40.06
51	1010	1023	14	17.47	33.74

Table C.2 — Psychoacoustic parameters for 8 kHz short FFT

index	w_low	w_high	width	bval	qsthr
0	0	1	2	0.32	30.29
1	2	3	2	0.95	30.29
2	4	5	2	1.57	25.29
3	6	7	2	2.19	22.29
4	8	9	2	2.80	22.29
5	10	11	2	3.40	17.29
6	12	13	2	3.99	17.29
7	14	15	2	4.56	15.29
8	16	17	2	5.12	15.29
9	18	19	2	5.66	15.29
10	20	21	2	6.18	15.29
11	22	23	2	6.68	15.29
12	24	25	2	7.16	15.29
13	26	27	2	7.63	15.29
14	28	29	2	8.07	15.29
15	30	31	2	8.50	15.29
16	32	33	2	8.90	15.29
17	34	35	2	9.29	15.29
18	36	37	2	9.67	15.29
19	38	39	2	10.03	15.29
20	40	41	2	10.37	15.29
21	42	44	3	10.77	17.05
22	45	47	3	11.23	17.05
23	48	50	3	11.66	17.05
24	51	53	3	12.06	17.05
25	54	56	3	12.44	17.05
26	57	59	3	12.79	17.05
27	60	63	4	13.18	18.30
28	64	67	4	13.59	18.30
29	68	71	4	13.97	18.30
30	72	75	4	14.32	18.30
31	76	80	5	14.69	19.27
32	81	85	5	15.07	19.27
33	86	90	5	15.42	19.27
34	91	96	6	15.77	20.06
35	97	102	6	16.13	20.06
36	103	109	7	16.49	20.73
37	110	116	7	16.85	20.73
38	117	124	8	17.20	21.31
39	125	127	3	17.44	17.05

Table C.3 — Psychoacoustic parameters for 11.025 kHz long FFT

index	w_low	w_high	width	bval	qsthr
0	0	6	7	0.19	45.73
1	7	13	7	0.57	45.73
2	14	20	7	0.95	45.73
3	21	27	7	1.33	40.73
4	28	34	7	1.71	40.73
5	35	41	7	2.08	37.73
6	42	48	7	2.45	37.73
7	49	55	7	2.82	37.73
8	56	62	7	3.18	32.73
9	63	69	7	3.54	32.73
10	70	76	7	3.89	32.73
11	77	83	7	4.24	30.73
12	84	90	7	4.59	30.73
13	91	97	7	4.92	30.73
14	98	105	8	5.28	31.31
15	106	113	8	5.65	31.31
16	114	121	8	6.01	31.31
17	122	129	8	6.36	31.31
18	130	137	8	6.70	31.31
19	138	146	9	7.06	31.82
20	147	155	9	7.42	31.82
21	156	164	9	7.77	31.82
22	165	173	9	8.11	31.82
23	174	183	10	8.46	32.28
24	184	193	10	8.82	32.28
25	194	203	10	9.16	32.28
26	204	214	11	9.50	32.69
27	215	225	11	9.85	32.69
28	226	237	12	10.19	33.07
29	238	249	12	10.54	33.07
30	250	262	13	10.88	33.42
31	263	275	13	11.22	33.42
32	276	289	14	11.56	33.74
33	290	304	15	11.90	34.04
34	305	320	16	12.24	34.32
35	321	337	17	12.59	34.58
36	338	355	18	12.94	34.83
37	356	374	19	13.28	35.06
38	375	394	20	13.62	35.29
39	395	415	21	13.96	35.50
40	416	438	23	14.29	35.89
41	439	462	24	14.63	36.08
42	463	488	26	14.96	36.43
43	489	516	28	15.29	36.75
44	517	546	30	15.63	37.05
45	547	579	33	15.96	37.46
46	580	614	35	16.30	37.72
47	615	652	38	16.63	38.07
48	653	693	41	16.97	38.40
49	694	737	44	17.30	38.71
50	738	785	48	17.64	39.09
51	786	836	51	17.97	39.35
52	837	891	55	18.30	39.68
53	892	950	59	18.64	39.98
54	951	1014	64	18.97	40.34
55	1015	1023	9	19.16	31.82

Table C.4 — Psychoacoustic parameters for 11.025 kHz short FFT

index	w_low	w_high	width	bval	qsthr
0	0	0	1	0.00	27.28
1	1	1	1	0.44	27.28
2	2	2	1	0.87	27.28
3	3	3	1	1.30	22.28
4	4	4	1	1.73	22.28
5	5	5	1	2.16	19.28
6	6	6	1	2.58	19.28
7	7	7	1	3.00	14.28
8	8	8	1	3.41	14.28
9	9	9	1	3.82	14.28
10	10	10	1	4.22	12.28
11	11	11	1	4.61	12.28
12	12	12	1	4.99	12.28
13	13	13	1	5.37	12.28
14	14	14	1	5.74	12.28
15	15	15	1	6.10	12.28
16	16	16	1	6.45	12.28
17	17	17	1	6.79	12.28
18	18	19	2	7.44	15.29
19	20	21	2	8.05	15.29
20	22	23	2	8.64	15.29
21	24	25	2	9.19	15.29
22	26	27	2	9.70	15.29
23	28	29	2	10.19	15.29
24	30	31	2	10.65	15.29
25	32	33	2	11.08	15.29
26	34	35	2	11.48	15.29
27	36	37	2	11.86	15.29
28	38	39	2	12.22	15.29
29	40	42	3	12.64	17.05
30	43	45	3	13.10	17.05
31	46	48	3	13.53	17.05
32	49	51	3	13.93	17.05
33	52	54	3	14.30	17.05
34	55	58	4	14.69	18.30
35	59	62	4	15.11	18.30
36	63	66	4	15.49	18.30
37	67	70	4	15.84	18.30
38	71	75	5	16.21	19.27
39	76	80	5	16.58	19.27
40	81	85	5	16.92	19.27
41	86	91	6	17.27	20.06
42	92	97	6	17.62	20.06
43	98	104	7	17.97	20.73
44	105	111	7	18.32	20.73
45	112	119	8	18.67	21.31
46	120	127	8	19.02	21.31

Table C.5 — Psychoacoustic parameters for 12 kHz long FFT

index	w_low	w_high	width	bval	qsthr
0	0	5	6	0.18	45.06
1	6	11	6	0.53	45.06
2	12	17	6	0.89	45.06
3	18	23	6	1.24	40.06
4	24	29	6	1.59	40.06
5	30	35	6	1.94	40.06
6	36	41	6	2.29	37.06
7	42	47	6	2.63	37.06
8	48	53	6	2.98	37.06
9	54	59	6	3.31	32.06
10	60	65	6	3.65	32.06
11	66	72	7	4.00	30.73
12	73	79	7	4.38	30.73
13	80	86	7	4.75	30.73
14	87	93	7	5.11	30.73
15	94	100	7	5.47	30.73
16	101	107	7	5.82	30.73
17	108	114	7	6.15	30.73
18	115	122	8	6.51	31.31
19	123	130	8	6.88	31.31
20	131	138	8	7.24	31.31
21	139	146	8	7.58	31.31
22	147	154	8	7.92	31.31
23	155	163	9	8.27	31.82
24	164	172	9	8.62	31.82
25	173	181	9	8.96	31.82
26	182	191	10	9.31	32.28
27	192	201	10	9.66	32.28
28	202	212	11	10.01	32.69
29	213	223	11	10.36	32.69
30	224	235	12	10.71	33.07
31	236	247	12	11.06	33.07
32	248	260	13	11.41	33.42
33	261	273	13	11.75	33.42
34	274	287	14	12.09	33.74
35	288	302	15	12.43	34.04
36	303	318	16	12.77	34.32
37	319	335	17	13.11	34.58
38	336	353	18	13.46	34.83
39	354	372	19	13.80	35.06
40	373	392	20	14.13	35.29
41	393	414	22	14.47	35.70
42	415	437	23	14.81	35.89
43	438	462	25	15.14	36.26
44	463	489	27	15.48	36.59
45	490	518	29	15.81	36.90
46	519	549	31	16.15	37.19
47	550	583	34	16.48	37.59
48	584	619	36	16.82	37.84
49	620	658	39	17.15	38.19
50	659	700	42	17.48	38.51
51	701	745	45	17.81	38.81
52	746	794	49	18.14	39.18
53	795	847	53	18.48	39.52
54	848	904	57	18.81	39.83
55	905	965	61	19.15	40.13
56	966	1023	58	19.47	39.91

Table C.6 — Psychoacoustic parameters for 12 kHz short FFT

index	w_low	w_high	width	bval	qsthr
0	0	0	1	0.00	27.28
1	1	1	1	0.47	27.28
2	2	2	1	0.95	27.28
3	3	3	1	1.42	22.28
4	4	4	1	1.88	22.28
5	5	5	1	2.35	19.28
6	6	6	1	2.81	19.28
7	7	7	1	3.26	14.28
8	8	8	1	3.70	14.28
9	9	9	1	4.14	12.28
10	10	10	1	4.57	12.28
11	11	11	1	4.98	12.28
12	12	12	1	5.39	12.28
13	13	13	1	5.79	12.28
14	14	14	1	6.18	12.28
15	15	15	1	6.56	12.28
16	16	16	1	6.93	12.28
17	17	17	1	7.28	12.28
18	18	18	1	7.63	12.28
19	19	20	2	8.28	15.29
20	21	22	2	8.90	15.29
21	23	24	2	9.48	15.29
22	25	26	2	10.02	15.29
23	27	28	2	10.53	15.29
24	29	30	2	11.00	15.29
25	31	32	2	11.45	15.29
26	33	34	2	11.86	15.29
27	35	36	2	12.25	15.29
28	37	38	2	12.62	15.29
29	39	40	2	12.96	15.29
30	41	43	3	13.36	17.05
31	44	46	3	13.80	17.05
32	47	49	3	14.21	17.05
33	50	52	3	14.59	17.05
34	53	55	3	14.94	17.05
35	56	59	4	15.32	18.30
36	60	63	4	15.71	18.30
37	64	67	4	16.08	18.30
38	68	72	5	16.45	19.27
39	73	77	5	16.83	19.27
40	78	82	5	17.19	19.27
41	83	88	6	17.54	20.06
42	89	94	6	17.90	20.06
43	95	101	7	18.26	20.73
44	102	108	7	18.62	20.73
45	109	116	8	18.97	21.31
46	117	124	8	19.32	21.31
47	125	127	3	19.55	17.05

Table C.7 — Psychoacoustic parameters for 16 kHz long FFT

index	w_low	w_high	width	bval	qsthr
0	0	4	5	0.20	43.30
1	5	9	5	0.59	43.10
2	10	14	5	0.99	38.30
3	15	19	5	1.38	38.10
4	20	24	5	1.77	38.00
5	25	29	5	2.16	35.10
6	30	34	5	2.54	35.30
7	35	39	5	2.92	30.00
8	40	44	5	3.29	30.00
9	45	49	5	3.66	28.30
10	50	54	5	4.03	28.30
11	55	59	5	4.39	28.30
12	60	64	5	4.74	28.30
13	65	69	5	5.09	28.30
14	70	74	5	5.43	28.30
15	75	80	6	5.79	28.30
16	81	86	6	6.18	28.30
17	87	92	6	6.56	28.00
18	93	98	6	6.92	29.27
19	99	104	6	7.28	29.27
20	105	110	6	7.63	29.27
21	111	116	6	7.96	29.27
22	117	123	7	8.31	29.27
23	124	130	7	8.68	29.06
24	131	137	7	9.03	30.06
25	138	144	7	9.37	30.06
26	145	152	8	9.71	30.06
27	153	160	8	10.07	30.73
28	161	168	8	10.41	30.73
29	169	177	9	10.75	30.73
30	178	186	9	11.10	31.31
31	187	196	10	11.45	31.31
32	197	206	10	11.80	31.82
33	207	217	11	12.14	31.82
34	218	228	11	12.48	32.28
35	229	240	12	12.82	32.28
36	241	253	13	13.16	32.69
37	254	267	14	13.51	32.69
38	268	282	15	13.86	33.07
39	283	298	16	14.21	33.46
40	299	315	17	14.56	33.82
41	316	333	18	14.90	34.12
42	334	352	19	15.24	34.42
43	353	373	21	15.58	34.68
44	374	395	22	15.91	35.15
45	396	419	24	16.25	35.32
46	420	445	26	16.58	35.73
47	446	473	28	16.92	35.91
48	474	503	30	17.25	36.42
49	504	536	33	17.59	36.75
50	537	571	35	17.93	37.11
51	572	609	38	18.26	37.34
52	610	650	41	18.60	37.63
53	651	694	44	18.94	38.12

54	695	741	47	19.27	38.17
55	742	791	50	19.60	41.52
56	792	845	54	19.94	41.84
57	846	903	58	20.27	42.13
58	904	965	62	20.61	44.41
59	966	1023	58	20.92	44.87

Table C.8 — Psychoacoustic parameters for 16 kHz short FFT

index	w_low	w_high	width	bval	qstr
0	0	0	1	0.00	27.28
1	1	1	1	0.63	27.28
2	2	2	1	1.26	22.28
3	3	3	1	1.88	22.28
4	4	4	1	2.50	19.28
5	5	5	1	3.11	14.28
6	6	6	1	3.70	14.28
7	7	7	1	4.28	12.28
8	8	8	1	4.85	12.28
9	9	9	1	5.39	12.28
10	10	10	1	5.92	12.28
11	11	11	1	6.43	12.28
12	12	12	1	6.93	12.28
13	13	13	1	7.40	12.28
14	14	14	1	7.85	12.28
15	15	15	1	8.29	12.28
16	16	16	1	8.70	12.28
17	17	17	1	9.10	12.28
18	18	18	1	9.49	12.28
19	19	19	1	9.85	12.28
20	20	20	1	10.20	12.28
21	21	22	2	10.85	15.29
22	23	24	2	11.44	15.29
23	25	26	2	11.99	15.29
24	27	28	2	12.50	15.29
25	29	30	2	12.96	15.29
26	31	32	2	13.39	15.29
27	33	34	2	13.78	15.29
28	35	36	2	14.15	15.29
29	37	39	3	14.57	17.05
30	40	42	3	15.03	17.05
31	43	45	3	15.45	17.05
32	46	48	3	15.84	17.05
33	49	51	3	16.19	17.05
34	52	55	4	16.57	18.30
35	56	59	4	16.97	18.30
36	60	63	4	17.33	18.30
37	64	68	5	17.71	19.27
38	69	73	5	18.09	19.27
39	74	78	5	18.44	19.27
40	79	84	6	18.80	20.06
41	85	90	6	19.17	20.06
42	91	97	7	19.53	20.73
43	98	104	7	19.89	20.73
44	105	112	8	20.25	24.31
45	113	120	8	20.61	24.31
46	121	127	7	20.92	23.73

Table C.9 — Psychoacoustic parameters for 22.05 kHz long FFT

index	w_low	w_high	width	bval	qsthr
0	0	3	4	0.22	43.30
1	4	7	4	0.65	43.30
2	8	11	4	1.09	38.30
3	12	15	4	1.52	38.30
4	16	19	4	1.95	38.30
5	20	23	4	2.37	35.30
6	24	27	4	2.79	35.30
7	28	31	4	3.21	30.30
8	32	35	4	3.62	30.30
9	36	39	4	4.02	28.30
10	40	43	4	4.41	28.30
11	44	47	4	4.80	28.30
12	48	51	4	5.18	28.30
13	52	55	4	5.55	28.30
14	56	59	4	5.92	28.30
15	60	63	4	6.27	28.30
16	64	67	4	6.62	28.30
17	68	71	4	6.95	28.30
18	72	76	5	7.32	29.27
19	77	81	5	7.71	29.27
20	82	86	5	8.10	29.27
21	87	91	5	8.46	29.27
22	92	96	5	8.82	29.27
23	97	101	5	9.16	29.27
24	102	107	6	9.52	30.06
25	108	113	6	9.89	30.06
26	114	119	6	10.25	30.06
27	120	125	6	10.59	30.06
28	126	132	7	10.95	30.73
29	133	139	7	11.31	30.73
30	140	146	7	11.65	30.73
31	147	154	8	12.00	31.31
32	155	162	8	12.35	31.31
33	163	171	9	12.70	31.82
34	172	180	9	13.05	31.82
35	181	190	10	13.40	32.28
36	191	200	10	13.74	32.28
37	201	211	11	14.07	32.69
38	212	223	12	14.41	33.07
39	224	236	13	14.76	33.42
40	237	250	14	15.11	33.74
41	251	265	15	15.46	34.04
42	266	281	16	15.80	34.32
43	282	298	17	16.14	34.58
44	299	317	19	16.48	35.06
45	318	337	20	16.82	35.29
46	338	359	22	17.16	35.70
47	360	382	23	17.50	35.89
48	383	407	25	17.84	36.26
49	408	434	27	18.17	36.59
50	435	463	29	18.51	36.90
51	464	494	31	18.84	37.19
52	495	527	33	19.17	37.46
53	528	563	36	19.51	37.84
54	564	601	38	19.84	38.07
55	602	642	41	20.17	41.40
56	643	686	44	20.50	41.71
57	687	733	47	20.84	42.00
58	734	784	51	21.17	44.35

59	785	839	55	21.50	44.68
60	840	898	59	21.84	44.98
61	899	962	64	22.17	50.34
62	963	1023	61	22.48	50.13

Table C.10 — Psychoacoustic parameters for 22.05 kHz short FFT

index	w_low	w_high	width	bval	qthr
0	0	0	1	0.00	27.28
1	1	1	1	0.87	27.28
2	2	2	1	1.73	22.28
3	3	3	1	2.58	19.28
4	4	4	1	3.41	14.28
5	5	5	1	4.22	12.28
6	6	6	1	4.99	12.28
7	7	7	1	5.74	12.28
8	8	8	1	6.45	12.28
9	9	9	1	7.12	12.28
10	10	10	1	7.75	12.28
11	11	11	1	8.36	12.28
12	12	12	1	8.92	12.28
13	13	13	1	9.45	12.28
14	14	14	1	9.96	12.28
15	15	15	1	10.43	12.28
16	16	16	1	10.87	12.28
17	17	17	1	11.29	12.28
18	18	18	1	11.68	12.28
19	19	19	1	12.05	12.28
20	20	21	2	12.71	15.29
21	22	23	2	13.32	15.29
22	24	25	2	13.86	15.29
23	26	27	2	14.35	15.29
24	28	29	2	14.80	15.29
25	30	31	2	15.21	15.29
26	32	33	2	15.58	15.29
27	34	35	2	15.93	15.29
28	36	38	3	16.32	17.05
29	39	41	3	16.75	17.05
30	42	44	3	17.15	17.05
31	45	47	3	17.51	17.05
32	48	51	4	17.89	18.30
33	52	55	4	18.30	18.30
34	56	59	4	18.67	18.30
35	60	63	4	19.02	18.30
36	64	68	5	19.37	19.27
37	69	73	5	19.74	19.27
38	74	78	5	20.09	22.27
39	79	84	6	20.44	23.06
40	85	90	6	20.79	23.06
41	91	97	7	21.15	25.73
42	98	104	7	21.50	25.73
43	105	112	8	21.85	26.31
44	113	120	8	22.20	31.31
45	121	127	7	22.49	30.73

Table C.11 — Psychoacoustic parameters for 24 kHz long FFT

index	w_low	w_high	width	bval	qsthr
0	0	2	3	0.18	42.05
1	3	5	3	0.53	42.05
2	6	8	3	0.89	42.05
3	9	11	3	1.24	37.05
4	12	14	3	1.59	37.05
5	15	17	3	1.94	37.05
6	18	20	3	2.29	34.05
7	21	23	3	2.63	34.05
8	24	26	3	2.98	34.05
9	27	29	3	3.31	29.05
10	30	32	3	3.65	29.05
11	33	36	4	4.03	28.30
12	37	40	4	4.46	28.30
13	41	44	4	4.88	28.30
14	45	48	4	5.29	28.30
15	49	52	4	5.69	28.30
16	53	56	4	6.08	28.30
17	57	60	4	6.46	28.30
18	61	64	4	6.83	28.30
19	65	68	4	7.19	28.30
20	69	72	4	7.54	28.30
21	73	76	4	7.88	28.30
22	77	81	5	8.25	29.27
23	82	86	5	8.64	29.27
24	87	91	5	9.02	29.27
25	92	96	5	9.38	29.27
26	97	101	5	9.73	29.27
27	102	107	6	10.09	30.06
28	108	113	6	10.47	30.06
29	114	119	6	10.83	30.06
30	120	125	6	11.18	30.06
31	126	132	7	11.53	30.73
32	133	139	7	11.89	30.73
33	140	146	7	12.23	30.73
34	147	154	8	12.57	31.31
35	155	162	8	12.92	31.31
36	163	171	9	13.26	31.82
37	172	180	9	13.61	31.82
38	181	190	10	13.95	32.28
39	191	201	11	14.29	32.69
40	202	213	12	14.65	33.07
41	214	225	12	15.00	33.07
42	226	238	13	15.33	33.42
43	239	252	14	15.66	33.74
44	253	267	15	16.00	34.04
45	268	284	17	16.34	34.58
46	285	302	18	16.69	34.83
47	303	321	19	17.02	35.06
48	322	342	21	17.36	35.50
49	343	364	22	17.70	35.70
50	365	388	24	18.03	36.08
51	389	414	26	18.37	36.43
52	415	442	28	18.70	36.75
53	443	472	30	19.04	37.05

54	473	504	32	19.38	37.33
55	505	538	34	19.71	37.59
56	539	575	37	20.04	40.96
57	576	614	39	20.38	41.19
58	615	656	42	20.71	41.51
59	657	701	45	21.04	43.81
60	702	750	49	21.37	44.18
61	751	803	53	21.70	44.52
62	804	860	57	22.04	49.83
63	861	922	62	22.37	50.20
64	923	989	67	22.70	50.54
65	990	1023	34	22.95	47.59

Table C.12 — Psychoacoustic parameters for 24 kHz short FFT

index	w_low	w_high	width	bval	qsthr
0	0	0	1	0.00	27.28
1	1	1	1	0.95	27.28
2	2	2	1	1.88	22.28
3	3	3	1	2.81	19.28
4	4	4	1	3.70	14.28
5	5	5	1	4.57	12.28
6	6	6	1	5.39	12.28
7	7	7	1	6.18	12.28
8	8	8	1	6.93	12.28
9	9	9	1	7.63	12.28
10	10	10	1	8.29	12.28
11	11	11	1	8.91	12.28
12	12	12	1	9.49	12.28
13	13	13	1	10.03	12.28
14	14	14	1	10.53	12.28
15	15	15	1	11.01	12.28
16	16	16	1	11.45	12.28
17	17	17	1	11.87	12.28
18	18	18	1	12.26	12.28
19	19	19	1	12.62	12.28
20	20	21	2	13.28	15.29
21	22	23	2	13.87	15.29
22	24	25	2	14.40	15.29
23	26	27	2	14.88	15.29
24	28	29	2	15.32	15.29
25	30	31	2	15.71	15.29
26	32	33	2	16.08	15.29
27	34	36	3	16.49	17.05
28	37	39	3	16.94	17.05
29	40	42	3	17.35	17.05
30	43	45	3	17.73	17.05
31	46	48	3	18.07	17.05
32	49	52	4	18.44	18.30
33	53	56	4	18.83	18.30
34	57	60	4	19.20	18.30
35	61	65	5	19.57	19.27
36	66	70	5	19.96	19.27
37	71	75	5	20.31	22.27
38	76	81	6	20.67	23.06
39	82	87	6	21.04	25.06
40	88	94	7	21.41	25.73
41	95	101	7	21.77	25.73
42	102	109	8	22.13	31.31
43	110	117	8	22.48	31.31
44	118	126	9	22.82	31.82
45	127	127	1	23.01	32.28

Table C.13 — Psychoacoustic parameters for 32 kHz long FFT

index	w_low	w_high	width	bval	qsthr
0	0	2	3	0.24	42.05
1	3	5	3	0.71	42.05
2	6	8	3	1.18	37.05
3	9	11	3	1.65	37.05
4	12	14	3	2.12	34.05
5	15	17	3	2.58	34.05
6	18	20	3	3.03	29.05
7	21	23	3	3.48	29.05
8	24	26	3	3.92	29.05
9	27	29	3	4.35	27.05
10	30	32	3	4.77	27.05
11	33	35	3	5.19	27.05
12	36	38	3	5.59	27.05
13	39	41	3	5.99	27.05
14	42	44	3	6.37	27.05
15	45	47	3	6.74	27.05
16	48	50	3	7.10	27.05
17	51	53	3	7.45	27.05
18	54	56	3	7.80	27.05
19	57	60	4	8.18	28.30
20	61	64	4	8.60	28.30
21	65	68	4	9.00	28.30
22	69	72	4	9.39	28.30
23	73	76	4	9.76	28.30
24	77	80	4	10.11	28.30
25	81	84	4	10.45	28.30
26	85	89	5	10.81	29.27
27	90	94	5	11.19	29.27
28	95	99	5	11.55	29.27
29	100	104	5	11.90	29.27
30	105	110	6	12.25	30.06
31	111	116	6	12.62	30.06
32	117	122	6	12.96	30.06
33	123	129	7	13.31	30.73
34	130	136	7	13.66	30.73
35	137	144	8	14.01	31.31
36	145	152	8	14.36	31.31
37	153	161	9	14.71	31.82
38	162	171	10	15.07	32.28
39	172	181	10	15.42	32.28
40	182	192	11	15.76	32.69
41	193	204	12	16.10	33.07
42	205	217	13	16.45	33.42
43	218	231	14	16.80	33.74
44	232	246	15	17.14	34.04
45	247	262	16	17.48	34.32
46	263	279	17	17.82	34.58
47	280	298	19	18.15	35.06
48	299	318	20	18.49	35.29
49	319	340	22	18.84	35.70
50	341	363	23	19.17	35.89
51	364	388	25	19.51	36.26
52	389	415	27	19.85	36.59
53	416	444	29	20.19	39.90
54	445	475	31	20.53	40.19
55	476	508	33	20.87	40.46
56	509	543	35	21.20	42.72
57	544	581	38	21.53	43.07
58	582	622	41	21.86	43.40

59	623	667	45	22.20	48.81
60	668	715	48	22.53	49.09
61	716	768	53	22.86	49.52
62	769	826	58	23.20	59.91
63	827	890	64	23.53	60.34
64	891	961	71	23.86	60.79
65	962	1023	62	24.00	65.89

Table C.14 — Psychoacoustic parameters for 32 kHz short FFT

index	w_low	w_high	width	bval	qstr
0	0	0	1	0.00	27.28
1	1	1	1	1.26	22.28
2	2	2	1	2.50	19.28
3	3	3	1	3.70	14.28
4	4	4	1	4.85	12.28
5	5	5	1	5.92	12.28
6	6	6	1	6.93	12.28
7	7	7	1	7.85	12.28
8	8	8	1	8.70	12.28
9	9	9	1	9.49	12.28
10	10	10	1	10.20	12.28
11	11	11	1	10.85	12.28
12	12	12	1	11.45	12.28
13	13	13	1	12.00	12.28
14	14	14	1	12.50	12.28
15	15	15	1	12.96	12.28
16	16	16	1	13.39	12.28
17	17	17	1	13.78	12.28
18	18	18	1	14.15	12.28
19	19	20	2	14.80	15.29
20	21	22	2	15.38	15.29
21	23	24	2	15.89	15.29
22	25	26	2	16.36	15.29
23	27	28	2	16.77	15.29
24	29	30	2	17.15	15.29
25	31	32	2	17.50	15.29
26	33	35	3	17.90	17.05
27	36	38	3	18.34	17.05
28	39	41	3	18.74	17.05
29	42	44	3	19.11	17.05
30	45	48	4	19.50	18.30
31	49	52	4	19.92	18.30
32	53	56	4	20.30	21.30
33	57	60	4	20.65	21.30
34	61	65	5	21.02	24.27
35	66	70	5	21.40	24.27
36	71	75	5	21.75	24.27
37	76	81	6	22.10	30.06
38	82	87	6	22.45	30.06
39	88	94	7	22.80	30.73
40	95	102	8	23.16	41.31
41	103	110	8	23.51	41.31
42	111	119	9	23.85	41.82
43	120	127	8	24.00	60.47

Table C.15 – Psychoacoustic parameters for 44.1 kHz long FFT

index	w_low	w_high	width	bval	qsthr
0	0	1	2	0.22	40.29
1	2	3	2	0.65	40.29
2	4	5	2	1.09	35.29
3	6	7	2	1.52	35.29
4	8	9	2	1.95	35.29
5	10	11	2	2.37	32.29
6	12	13	2	2.79	32.29
7	14	15	2	3.21	27.29
8	16	17	2	3.62	27.29
9	18	19	2	4.02	25.29
10	20	21	2	4.41	25.29
11	22	23	2	4.80	25.29
12	24	25	2	5.18	25.29
13	26	27	2	5.55	25.29
14	28	29	2	5.92	25.29
15	30	31	2	6.27	25.29
16	32	33	2	6.62	25.29
17	34	35	2	6.95	25.29
18	36	38	3	7.36	27.05
19	39	41	3	7.83	27.05
20	42	44	3	8.28	27.05
21	45	47	3	8.71	27.05
22	48	50	3	9.12	27.05
23	51	53	3	9.52	27.05
24	54	56	3	9.89	27.05
25	57	59	3	10.25	27.05
26	60	62	3	10.59	27.05
27	63	66	4	10.97	28.30
28	67	70	4	11.38	28.30
29	71	74	4	11.77	28.30
30	75	78	4	12.13	28.30
31	79	82	4	12.48	28.30
32	83	87	5	12.84	29.27
33	88	92	5	13.22	29.27
34	93	97	5	13.57	29.27
35	98	103	6	13.93	30.06
36	104	109	6	14.30	30.06
37	110	116	7	14.67	30.73
38	117	123	7	15.03	30.73
39	124	131	8	15.40	31.31
40	132	139	8	15.76	31.31
41	140	148	9	16.11	31.82
42	149	157	9	16.45	31.82
43	158	167	10	16.79	32.28
44	168	178	11	17.13	32.69
45	179	190	12	17.48	33.07
46	191	203	13	17.83	33.42
47	204	217	14	18.18	33.74
48	218	232	15	18.52	34.04
49	233	248	16	18.87	34.32
50	249	265	17	19.21	34.58
51	266	283	18	19.54	34.83
52	284	303	20	19.88	35.29
53	304	324	21	20.22	38.50

54	325	347	23	20.56	38.89
55	348	371	24	20.90	39.08
56	372	397	26	21.24	41.43
57	398	425	28	21.57	41.75
58	426	455	30	21.91	42.05
59	456	488	33	22.24	47.46
60	489	524	36	22.58	47.84
61	525	563	39	22.91	48.19
62	564	606	43	23.25	58.61
63	607	653	47	23.58	59.00
64	654	706	53	23.91	59.52
65	707	765	59	24.00	69.98
66	766	832	67	24.00	70.54
67	833	908	76	24.00	71.08
68	909	996	88	24.00	71.72
69	997	1023	27	24.00	72.09

Table C.16 — Psychoacoustic parameters for 44.1 kHz short FFT

index	w_low	w_high	width	bval	qsthr
0	0	0	1	0.00	27.28
1	1	1	1	1.73	22.28
2	2	2	1	3.41	14.28
3	3	3	1	4.99	12.28
4	4	4	1	6.45	12.28
5	5	5	1	7.75	12.28
6	6	6	1	8.92	12.28
7	7	7	1	9.96	12.28
8	8	8	1	10.87	12.28
9	9	9	1	11.68	12.28
10	10	10	1	12.39	12.28
11	11	11	1	13.03	12.28
12	12	12	1	13.61	12.28
13	13	13	1	14.12	12.28
14	14	14	1	14.59	12.28
15	15	15	1	15.01	12.28
16	16	16	1	15.40	12.28
17	17	17	1	15.76	12.28
18	18	19	2	16.39	15.29
19	20	21	2	16.95	15.29
20	22	23	2	17.45	15.29
21	24	25	2	17.89	15.29
22	26	27	2	18.30	15.29
23	28	29	2	18.67	15.29
24	30	31	2	19.02	15.29
25	32	34	3	19.41	17.05
26	35	37	3	19.85	17.05
27	38	40	3	20.25	20.05
28	41	43	3	20.62	20.05
29	44	47	4	21.01	23.30
30	48	51	4	21.43	23.30
31	52	55	4	21.81	23.30
32	56	59	4	22.15	28.30
33	60	64	5	22.51	29.27
34	65	69	5	22.87	29.27
35	70	75	6	23.23	40.06
36	76	81	6	23.59	40.06
37	82	88	7	23.93	40.73
38	89	96	8	24.00	51.31
39	97	105	9	24.00	51.82
40	106	115	10	24.00	52.28
41	116	127	12	24.00	53.07

Table C.17 — Psychoacoustic parameters for 48 kHz long FFT

index	w_low	w_high	width	bval	qsthr
0	0	1	2	0.24	40.29
1	2	3	2	0.71	40.29
2	4	5	2	1.18	35.29
3	6	7	2	1.65	35.29
4	8	9	2	2.12	32.29
5	10	11	2	2.58	32.29
6	12	13	2	3.03	27.29
7	14	15	2	3.48	27.29
8	16	17	2	3.92	27.29
9	18	19	2	4.35	25.29
10	20	21	2	4.77	25.29
11	22	23	2	5.19	25.29
12	24	25	2	5.59	25.29
13	26	27	2	5.99	25.29
14	28	29	2	6.37	25.29
15	30	31	2	6.74	25.29
16	32	33	2	7.10	25.29
17	34	35	2	7.45	25.29
18	36	37	2	7.80	25.29
19	38	40	3	8.20	27.05
20	41	43	3	8.68	27.05
21	44	46	3	9.13	27.05
22	47	49	3	9.55	27.05
23	50	52	3	9.96	27.05
24	53	55	3	10.35	27.05
25	56	58	3	10.71	27.05
26	59	61	3	11.06	27.05
27	62	65	4	11.45	28.30
28	66	69	4	11.86	28.30
29	70	73	4	12.25	28.30
30	74	77	4	12.62	28.30
31	78	81	4	12.96	28.30
32	82	86	5	13.32	29.27
33	87	91	5	13.70	29.27
34	92	96	5	14.05	29.27
35	97	102	6	14.41	30.06
36	103	108	6	14.77	30.06
37	109	115	7	15.13	30.73
38	116	122	7	15.49	30.73
39	123	130	8	15.85	31.31
40	131	138	8	16.20	31.31
41	139	147	9	16.55	31.82
42	148	157	10	16.91	32.28
43	158	167	10	17.25	32.28
44	168	178	11	17.59	32.69
45	179	190	12	17.93	33.07
46	191	203	13	18.28	33.42
47	204	217	14	18.62	33.74
48	218	232	15	18.96	34.04
49	233	248	16	19.30	34.32
50	249	265	17	19.64	34.58
51	266	283	18	19.97	34.83
52	284	303	20	20.31	38.29
53	304	324	21	20.65	38.50

54	325	347	23	20.99	38.89
55	348	371	24	21.33	41.08
56	372	397	26	21.66	41.43
57	398	425	28	21.99	41.75
58	426	456	31	22.32	47.19
59	457	490	34	22.66	47.59
60	491	527	37	23.00	47.96
61	528	567	40	23.33	58.30
62	568	612	45	23.67	58.81
63	613	662	50	24.00	69.27
64	663	718	56	24.00	69.76
65	719	781	63	24.00	70.27
66	782	853	72	24.00	70.85
67	854	937	84	24.00	71.52
68	938	1023	86	24.00	70.20

Table C.18 — Psychoacoustic parameters for 48 kHz short FFT

index	w_low	w_high	width	bval	qsthr
0	0	0	1	0.00	27.28
1	1	1	1	1.88	22.28
2	2	2	1	3.70	14.28
3	3	3	1	5.39	12.28
4	4	4	1	6.93	12.28
5	5	5	1	8.29	12.28
6	6	6	1	9.49	12.28
7	7	7	1	10.53	12.28
8	8	8	1	11.45	12.28
9	9	9	1	12.26	12.28
10	10	10	1	12.96	12.28
11	11	11	1	13.59	12.28
12	12	12	1	14.15	12.28
13	13	13	1	14.65	12.28
14	14	14	1	15.11	12.28
15	15	15	1	15.52	12.28
16	16	16	1	15.90	12.28
17	17	18	2	16.56	15.29
18	19	20	2	17.15	15.29
19	21	22	2	17.66	15.29
20	23	24	2	18.13	15.29
21	25	26	2	18.54	15.29
22	27	28	2	18.93	15.29
23	29	30	2	19.28	15.29
24	31	33	3	19.69	17.05
25	34	36	3	20.14	20.05
26	37	39	3	20.54	20.05
27	40	42	3	20.92	20.05
28	43	45	3	21.27	22.05
29	46	49	4	21.64	23.30
30	50	53	4	22.03	28.30
31	54	57	4	22.39	28.30
32	58	62	5	22.76	29.27
33	63	67	5	23.13	39.27
34	68	73	6	23.49	40.06
35	74	79	6	23.85	40.06
36	80	86	7	24.00	50.73
37	87	94	8	24.00	51.31
38	95	103	9	24.00	51.82
39	104	113	10	24.00	52.28
40	114	125	12	24.00	53.07
41	126	127	1	24.00	53.07

Table C.19 — Psychoacoustic parameters for 64 kHz long FFT

index	w_low	w_high	width	bval	qsthr
0	0	1	2	0.32	40.29
1	2	3	2	0.95	40.29
2	4	5	2	1.57	35.29
3	6	7	2	2.19	32.29
4	8	9	2	2.80	32.29
5	10	11	2	3.40	27.29
6	12	13	2	3.99	27.29
7	14	15	2	4.56	25.29
8	16	17	2	5.12	25.29
9	18	19	2	5.66	25.29
10	20	21	2	6.18	25.29
11	22	23	2	6.68	25.29
12	24	25	2	7.16	25.29
13	26	27	2	7.63	25.29
14	28	29	2	8.07	25.29
15	30	31	2	8.50	25.29
16	32	33	2	8.90	25.29
17	34	35	2	9.29	25.29
18	36	37	2	9.67	25.29
19	38	39	2	10.03	25.29
20	40	41	2	10.37	25.29
21	42	44	3	10.77	27.05
22	45	47	3	11.23	27.05
23	48	50	3	11.66	27.05
24	51	53	3	12.06	27.05
25	54	56	3	12.44	27.05
26	57	59	3	12.79	27.05
27	60	63	4	13.18	28.30
28	64	67	4	13.59	28.30
29	68	71	4	13.97	28.30
30	72	75	4	14.32	28.30
31	76	80	5	14.69	29.27
32	81	85	5	15.07	29.27
33	86	90	5	15.42	29.27
34	91	96	6	15.77	30.06
35	97	102	6	16.13	30.06
36	103	109	7	16.49	30.73
37	110	116	7	16.85	30.73
38	117	124	8	17.20	31.31
39	125	132	8	17.54	31.31
40	133	141	9	17.88	31.82
41	142	151	10	18.23	32.28
42	152	161	10	18.58	32.28
43	162	172	11	18.91	32.69
44	173	184	12	19.25	33.07
45	185	197	13	19.60	33.42
46	198	211	14	19.94	33.74
47	212	226	15	20.29	37.04
48	227	242	16	20.63	37.32
49	243	259	17	20.97	37.58
50	260	277	18	21.31	39.83
51	278	297	20	21.64	40.29
52	298	318	21	21.98	40.50
53	319	341	23	22.31	45.89

54	342	366	25	22.65	46.26
55	367	394	28	22.98	46.75
56	395	424	30	23.32	57.05
57	425	458	34	23.66	57.59
58	459	495	37	23.99	57.96
59	496	537	42	24.00	68.51
60	538	584	47	24.00	69.00
61	585	638	54	24.00	69.60
62	639	701	63	24.00	70.27
63	702	774	73	24.00	70.91
64	775	861	87	24.00	71.67
65	862	966	105	24.00	72.49
66	967	1023	57	24.00	69.83

Table C.20 – Psychoacoustic parameters for 64 kHz short FFT

index	w_low	w_high	width	bval	qsthr
0	0	0	1	0.00	27.28
1	1	1	1	2.50	19.28
2	2	2	1	4.85	12.28
3	3	3	1	6.93	12.28
4	4	4	1	8.70	12.28
5	5	5	1	10.20	12.28
6	6	6	1	11.45	12.28
7	7	7	1	12.50	12.28
8	8	8	1	13.39	12.28
9	9	9	1	14.15	12.28
10	10	10	1	14.81	12.28
11	11	11	1	15.39	12.28
12	12	12	1	15.90	12.28
13	13	13	1	16.36	12.28
14	14	14	1	16.78	12.28
15	15	15	1	17.16	12.28
16	16	17	2	17.82	15.29
17	18	19	2	18.40	15.29
18	20	21	2	18.92	15.29
19	22	23	2	19.39	15.29
20	24	25	2	19.82	15.29
21	26	27	2	20.21	18.29
22	28	29	2	20.57	18.29
23	30	32	3	20.98	20.05
24	33	35	3	21.43	22.05
25	36	38	3	21.84	22.05
26	39	41	3	22.22	27.05
27	42	45	4	22.61	28.30
28	46	49	4	23.02	38.30
29	50	53	4	23.39	38.30
30	54	58	5	23.75	39.27
31	59	63	5	24.00	49.27
32	64	69	6	24.00	50.06
33	70	76	7	24.00	50.73
34	77	84	8	24.00	51.31
35	85	93	9	24.00	51.82
36	94	104	11	24.00	52.69
37	105	117	13	24.00	53.42
38	118	127	10	24.00	52.28

Table C.21 — Psychoacoustic parameters for 88.2 kHz long FFT

index	w_low	w_high	width	bval	qsthr
0	0	0	1	0.00	37.28
1	1	1	1	0.44	37.28
2	2	2	1	0.87	37.28
3	3	3	1	1.30	32.28
4	4	4	1	1.73	32.28
5	5	5	1	2.16	29.28
6	6	6	1	2.58	29.28
7	7	7	1	3.00	24.28
8	8	8	1	3.41	24.28
9	9	9	1	3.82	24.28
10	10	10	1	4.22	22.28
11	11	11	1	4.61	22.28
12	12	12	1	4.99	22.28
13	13	13	1	5.37	22.28
14	14	14	1	5.74	22.28
15	15	15	1	6.10	22.28
16	16	16	1	6.45	22.28
17	17	17	1	6.79	22.28
18	18	19	2	7.44	25.29
19	20	21	2	8.05	25.29
20	22	23	2	8.64	25.29
21	24	25	2	9.19	25.29
22	26	27	2	9.70	25.29
23	28	29	2	10.19	25.29
24	30	31	2	10.65	25.29
25	32	33	2	11.08	25.29
26	34	35	2	11.48	25.29
27	36	37	2	11.86	25.29
28	38	39	2	12.22	25.29
29	40	42	3	12.64	27.05
30	43	45	3	13.10	27.05
31	46	48	3	13.53	27.05
32	49	51	3	13.93	27.05
33	52	54	3	14.30	27.05
34	55	58	4	14.69	28.30
35	59	62	4	15.11	28.30
36	63	66	4	15.49	28.30
37	67	70	4	15.84	28.30
38	71	75	5	16.21	29.27
39	76	80	5	16.58	29.27
40	81	85	5	16.92	29.27
41	86	91	6	17.27	30.06
42	92	97	6	17.62	30.06
43	98	104	7	17.97	30.73
44	105	111	7	18.32	30.73
45	112	119	8	18.67	31.31
46	120	127	8	19.02	31.31
47	128	136	9	19.35	31.82
48	137	146	10	19.71	32.28
49	147	156	10	20.05	35.28
50	157	167	11	20.39	35.69
51	168	179	12	20.73	36.07
52	180	192	13	21.08	38.42
53	193	206	14	21.43	38.74

54	207	221	15	21.77	39.04
55	222	237	16	22.11	44.32
56	238	255	18	22.45	44.83
57	256	274	19	22.80	45.06
58	275	295	21	23.13	55.50
59	296	318	23	23.47	55.89
60	319	344	26	23.81	56.43
61	345	373	29	24.00	66.90
62	374	405	32	24.00	67.33
63	406	442	37	24.00	67.96
64	443	484	42	24.00	68.51
65	485	533	49	24.00	69.18
66	534	591	58	24.00	69.91
67	592	660	69	24.00	70.66
68	661	745	85	24.00	71.57
69	746	851	106	24.00	72.53
70	852	988	137	24.00	73.64
71	989	1023	35	24.00	67.72

Table C.22 — Psychoacoustic parameters for 88.2 kHz short FFT

index	w_low	w_high	width	bval	qsthr
0	0	0	1	0.00	27.28
1	1	1	1	3.41	14.28
2	2	2	1	6.45	12.28
3	3	3	1	8.92	12.28
4	4	4	1	10.87	12.28
5	5	5	1	12.39	12.28
6	6	6	1	13.61	12.28
7	7	7	1	14.59	12.28
8	8	8	1	15.40	12.28
9	9	9	1	16.09	12.28
10	10	10	1	16.69	12.28
11	11	11	1	17.21	12.28
12	12	12	1	17.68	12.28
13	13	13	1	18.11	12.28
14	14	14	1	18.49	12.28
15	15	15	1	18.85	12.28
16	16	17	2	19.48	15.29
17	18	19	2	20.05	18.29
18	20	21	2	20.55	18.29
19	22	23	2	21.01	20.29
20	24	25	2	21.43	20.29
21	26	27	2	21.81	20.29
22	28	29	2	22.15	25.29
23	30	32	3	22.55	27.05
24	33	35	3	22.98	27.05
25	36	38	3	23.36	37.05
26	39	42	4	23.75	38.30
27	43	46	4	24.00	48.30
28	47	51	5	24.00	49.27
29	52	56	5	24.00	49.27
30	57	62	6	24.00	50.06
31	63	69	7	24.00	50.73
32	70	77	8	24.00	51.31
33	78	87	10	24.00	52.28
34	88	99	12	24.00	53.07
35	100	115	16	24.00	54.32
36	116	127	12	24.00	53.07

Table C.23 — Psychoacoustic parameters for 96 kHz long FFT

index	w_low	w_high	width	bval	qsthr
0	0	0	1	0.00	37.28
1	1	1	1	0.47	37.28
2	2	2	1	0.95	37.28
3	3	3	1	1.42	32.28
4	4	4	1	1.88	32.28
5	5	5	1	2.35	29.28
6	6	6	1	2.81	29.28
7	7	7	1	3.26	24.28
8	8	8	1	3.70	24.28
9	9	9	1	4.14	22.28
10	10	10	1	4.57	22.28
11	11	11	1	4.98	22.28
12	12	12	1	5.39	22.28
13	13	13	1	5.79	22.28
14	14	14	1	6.18	22.28
15	15	15	1	6.56	22.28
16	16	16	1	6.93	22.28
17	17	17	1	7.28	22.28
18	18	18	1	7.63	22.28
19	19	20	2	8.28	25.29
20	21	22	2	8.90	25.29
21	23	24	2	9.48	25.29
22	25	26	2	10.02	25.29
23	27	28	2	10.53	25.29
24	29	30	2	11.00	25.29
25	31	32	2	11.45	25.29
26	33	34	2	11.86	25.29
27	35	36	2	12.25	25.29
28	37	38	2	12.62	25.29
29	39	40	2	12.96	25.29
30	41	43	3	13.36	27.05
31	44	46	3	13.80	27.05
32	47	49	3	14.21	27.05
33	50	52	3	14.59	27.05
34	53	55	3	14.94	27.05
35	56	59	4	15.32	28.30
36	60	63	4	15.71	28.30
37	64	67	4	16.08	28.30
38	68	72	5	16.45	29.27
39	73	77	5	16.83	29.27
40	78	82	5	17.19	29.27
41	83	88	6	17.54	30.06
42	89	94	6	17.90	30.06
43	95	101	7	18.26	30.73
44	102	108	7	18.62	30.73
45	109	116	8	18.97	31.31
46	117	124	8	19.32	31.31
47	125	133	9	19.67	31.82
48	134	143	10	20.03	35.28
49	144	153	10	20.38	35.28
50	154	164	11	20.72	35.69
51	165	176	12	21.07	38.07
52	177	189	13	21.42	38.42
53	190	203	14	21.77	38.74

54	204	218	15	22.12	44.04
55	219	234	16	22.46	44.32
56	235	252	18	22.80	44.83
57	253	271	19	23.14	55.06
58	272	292	21	23.47	55.50
59	293	316	24	23.81	56.08
60	317	342	26	24.00	66.43
61	343	372	30	24.00	67.05
62	373	406	34	24.00	67.59
63	407	445	39	24.00	68.19
64	446	490	45	24.00	68.81
65	491	543	53	24.00	69.52
66	544	607	64	24.00	70.34
67	608	685	78	24.00	71.20
68	686	783	98	24.00	72.19
69	784	910	127	24.00	73.31
70	911	1023	113	24.00	72.81

Table C.24 — Psychoacoustic parameters for 96 kHz short FFT

index	w_low	w_high	width	bval	qsthr
0	0	0	1	0.00	27.28
1	1	1	1	3.70	14.28
2	2	2	1	6.93	12.28
3	3	3	1	9.49	12.28
4	4	4	1	11.45	12.28
5	5	5	1	12.96	12.28
6	6	6	1	14.15	12.28
7	7	7	1	15.11	12.28
8	8	8	1	15.90	12.28
9	9	9	1	16.57	12.28
10	10	10	1	17.16	12.28
11	11	11	1	17.67	12.28
12	12	12	1	18.13	12.28
13	13	13	1	18.55	12.28
14	14	14	1	18.93	12.28
15	15	16	2	19.60	15.29
16	17	18	2	20.20	18.29
17	19	20	2	20.73	18.29
18	21	22	2	21.21	20.29
19	23	24	2	21.64	20.29
20	25	26	2	22.03	25.29
21	27	28	2	22.39	25.29
22	29	31	3	22.79	27.05
23	32	34	3	23.23	37.05
24	35	37	3	23.62	37.05
25	38	41	4	24.00	48.30
26	42	45	4	24.00	48.30
27	46	50	5	24.00	49.27
28	51	55	5	24.00	49.27
29	56	61	6	24.00	50.06
30	62	68	7	24.00	50.73
31	69	77	9	24.00	51.82
32	78	88	11	24.00	52.69
33	89	102	14	24.00	53.74
34	103	120	18	24.00	54.83
35	121	127	7	24.00	50.73

C.2 Gain Control

C.2.1 Encoding Process

The gain control tool consists of a PQF (Polyphase Quadrature Filter), gain detectors and gain modifiers. This tool receives the input time-domain signals and **window_sequence**, and then outputs **gain_control_data** and a gain controlled signal whose length is equal to the length of the MDCT window. The block diagram for the gain control tool is shown in Figure C.2 .

Due to the characteristics of the PQF filterbank, the order of the MDCT coefficients in each even PQF band needs to be reversed. This is done by reversing the spectral order of the MDCT coefficients, i.e. exchanging the higher frequency MDCT coefficients with the lower frequency MDCT coefficients.

If the gain control tool is used, the configuration of the filterbank tool is changed as follows. In the case of an **EIGHT_SHORT_SEQUENCE** **window_sequence**, the number of coefficients for the MDCT is 32 instead of

128 and eight MDCTs are carried out. In the case of other window_sequence values, the number of coefficients for the MDCT is 256 instead of 1024 and one MDCT is carried out. In all cases, the filter bank tool receives a total of 2048 gain controlled signal values per frame, because the input samples have been overlapped.

C.2.1.1 PQF

The input signal is divided by a PQF into four equal width frequency bands. The coefficients of each band PQF are given as follows.

$$h_i(n) = \frac{1}{4} \cos\left(\frac{(2i+1)(2n+5)\pi}{16}\right) Q(n), 0 \leq n \leq 95, 0 \leq i \leq 3$$

where

$$Q(n) = Q(95 - n), 48 \leq n \leq 95$$

and the values of Q(n) are the same values as those of the decoder.

C.2.1.2 Gain Detector

The gain detectors produce gain control data which satisfies the bitstream syntax. This information consists of the number of gain changes, the index of gain change positions and the index of gain change level. Note that the output gain control data applies to the previous input time signal. This means that the gain detector has a one frame delay.

The detection of the gain change point is done in the second half of the MDCT window region and in the non-overlapped region (of LONG_START_SEQUENCE and LONG_STOP_SEQUENCE). Thus the number of regions are one for ONLY_LONG_SEQUENCE, two for LONG_START_SEQUENCE and LONG_STOP_SEQUENCE, and eight for EIGHT_SHORT_SEQUENCE.

The samples in each region are divided into subregions, each having eight-tuple samples. Then one value (e.g. peak value of samples) is selected in these subregions. The ratios between the values of subregions and the value of the last subregion are calculated. If the ratio is greater or less than the value of 2 ^ n where n is an integer between -4 to 11, those subregions can be detected as the gain change points of the signals. The subregion number which is detected as the gain change point is set to be the position data. The exponent of the ratio is set to be the gain data. The time resolution of the gain control is approximately 0.7 ms at 48 kHz sampling rate.

C.2.1.3 Gain Modifier

The gain modifier for each PQF band controls the gain of each signal band. The complementary gain control process in the decoder decreases the pre-echo and reconstructs the original signal. A window function for gain control, the Gain Modification Function (GMF), which is defined in the decoding process, is derived from the gains and the gain-changed positions. The gain controlled signals are derived by applying the GMF to the corresponding band signals.

C.2.2 Diagrams

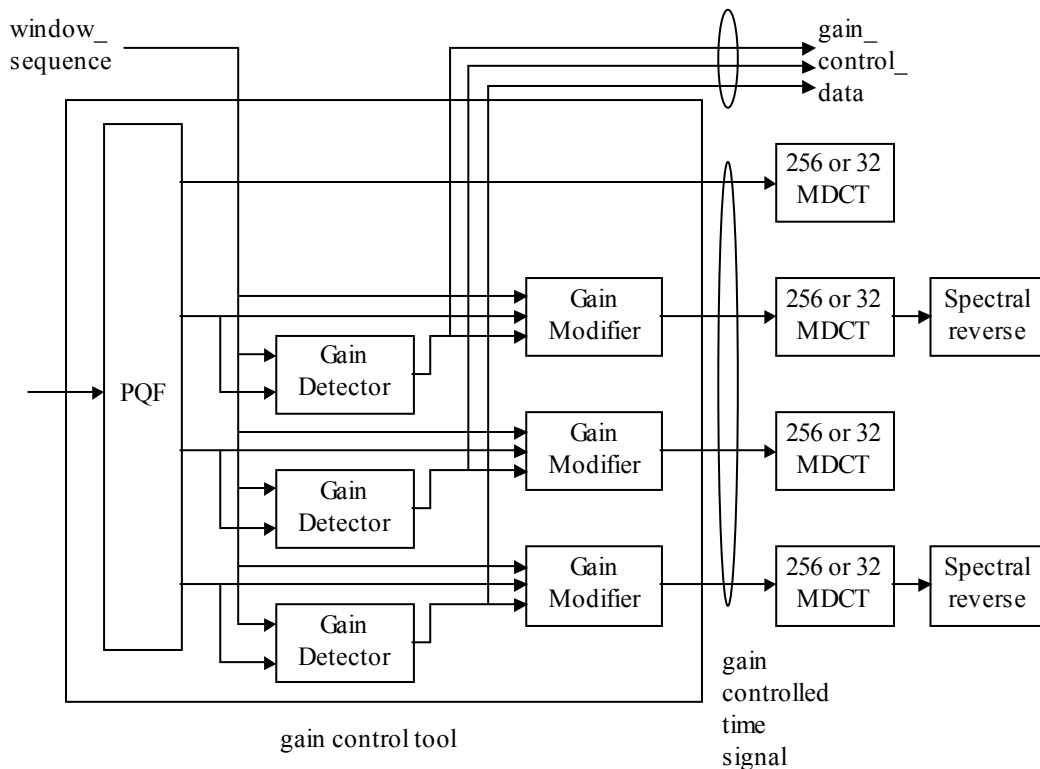

Figure C.2 — Block diagram of gain control tool for encoder

C.3 Filterbank and Block Switching

A fundamental component in the audio coding process is the conversion of the time domain signals into a time-frequency representation. This conversion is done by a forward modified discrete cosine transform (MDCT).

C.3.1 Encoding Process

In the encoder the filterbank takes the appropriate block of time samples, modulates them by an appropriate window function, and performs the MDCT. Each block of input samples is overlapped by 50% with the immediately preceding block and the following block. The transform input block length N can be set to either 2048 or 256 samples. Since the window function has a significant effect on the filterbank frequency response, the filterbank has been designed to allow a change in window shape to best adapt to input signal conditions. The shape of the window is varied simultaneously in the encoder and decoder to allow the filterbank to efficiently separate spectral components of the input for a wider variety of input signals.

C.3.1.1 Windowing and Block Switching

The adaptation of the time-frequency resolution of the filterbank to the characteristics of the input signal is done by shifting between transforms whose input lengths are either 2048 or 256 samples. The meaningful transitions are described in subclause 15.3.1.

Window shape decisions are made by the encoder on a frame-by-frame-basis. The window selected is applicable to the second half of the window function only, since the first half is constrained to use the

appropriate window shape from the preceding frame. Figure C.3 shows the sequence of blocks for the transition (D-E-F) to and from a frame employing the sine function window. The window shape selector generally produces window shape run-lengths greater than that shown in the figure.

The 2048 time-domain values $x'_{i,n}$ to be windowed are the last 1024 values of the previous window_sequence concatenated with 1024 values of the current block. The formula below shows this fact:

$$x'_{i,n} = \begin{cases} x_{(i-1),(n+1024)}, & \text{for } 0 \leq n < 1024 \\ x_{i,n}, & \text{for } 1024 \leq n < 2048 \end{cases}$$

Where i is the block index and n is the sample index within a block. Once the window shape is selected, the **window_shape** syntax element is initialized. Together with the chosen **window_sequence** all information needed for windowing exist.

With the window halves described in subclause 15.3.2, all **window_sequence**'s can be assembled.

C.3.1.2 MDCT

The spectral coefficient, $X_{i,k}$, are defined as follows:

$$X_{i,k} = 2 \cdot \sum_{n=0}^{N-1} z_{i,n} \cos\left(\frac{2\pi}{N}(n+n_0)\left(k+\frac{1}{2}\right)\right) \text{ for } 0 \leq k < N/2.$$

where :

z_{in} = windowed input sequence

n = sample index

k = spectral coefficient index

i = block index

N = window length of the one transform window based on the window_sequence value

$n_0 = (N/2 + 1)/2$

The analysis window length N of one transform window of the mdct is a function of the syntax element **window_sequence** and is defined as follows:

$$N = \begin{cases} 2048, & \text{if ONLY_LONG_SEQUENCE (0x0)} \\ 2048, & \text{if LONG_START_SEQUENCE (0x1)} \\ 256, & \text{if EIGHT_SHORT_SEQUENCE (0x2) (8 times)} \\ 2048, & \text{if LONG_STOP_SEQUENCE (0x3)} \end{cases}$$

C.3.2 Diagrams

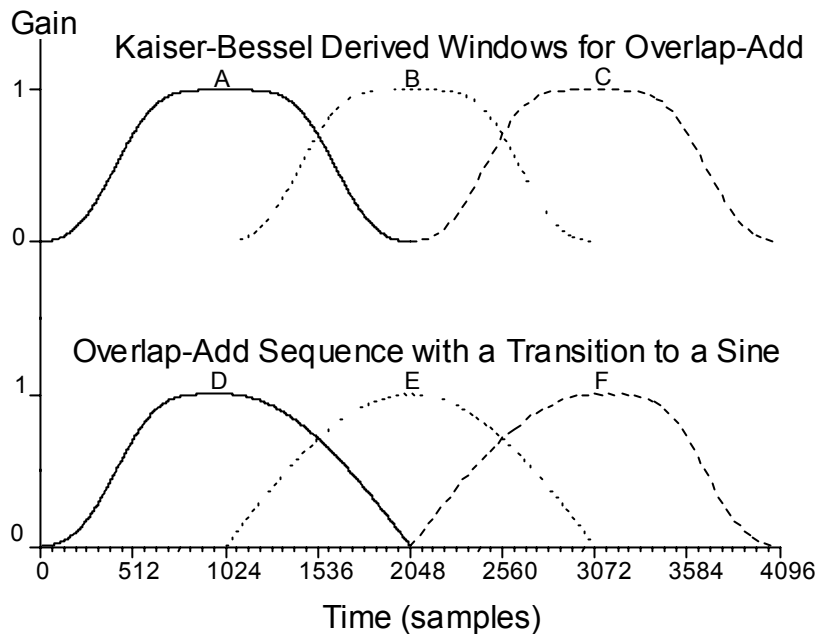

Figure C.3 — Example of the Window Shape Adaptation Process.

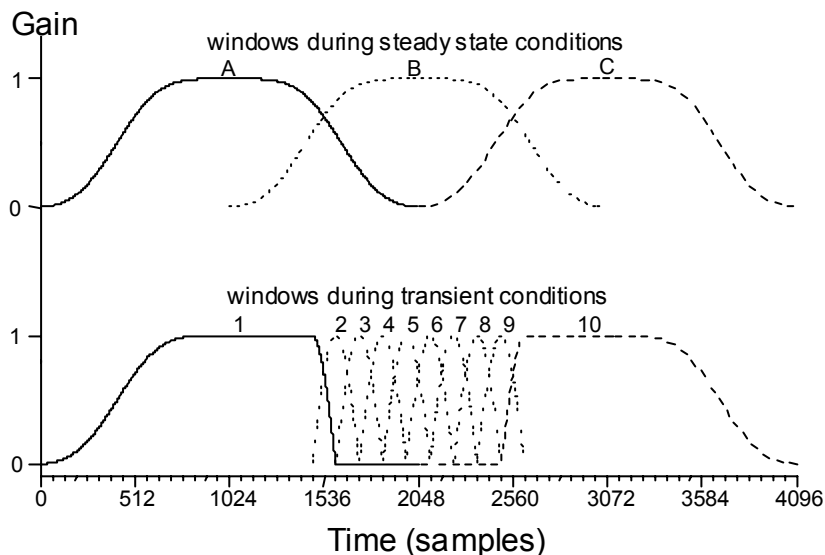

Figure C.4 — Example of Block Switching During Transient Signal Conditions

C.4 Prediction

C.4.1 Tool Description

Since each predictor itself is identical on both, the encoder and decoder side, all descriptions and definitions as specified for the decoder in clause 13 are also valid here.

Prediction is used for an improved redundancy reduction and is especially effective in case of more or less stationary parts of a signal which belong to the most demanding parts in terms of required bitrate. Prediction can be applied to every channel using an intra channel (or mono) predictor which exploits the auto-correlation between the spectral components of consecutive frames. Because a window_sequence of type EIGHT_SHORT_SEQUENCE indicates signal changes, i.e. non-stationary signal characteristic, prediction is only used if window_sequence is of type ONLY_LONG_SEQUENCE, LONG_START_SEQUENCE or LONG_STOP_SEQUENCE.

For each channel prediction is applied to the spectral components resulting from the spectral decomposition of the filterbank. For each spectral component up to limit specified by PRED_SFB_MAX, there is one corresponding predictor resulting in a bank of predictors, where each predictor exploits the auto-correlation between the spectral component values of consecutive frames.

The overall coding structure using a filterbank with high spectral resolution implies the use of backward adaptive predictors to achieve high coding efficiency. In this case, the predictor coefficients are calculated from preceding quantized spectral components in the encoder as well as in the decoder and no additional side information is needed for the transmission of predictor coefficients - as would be required for forward adaptive predictors. A second order backward-adaptive lattice structure predictor is used for each spectral component, so that each predictor is working on the spectral component values of the two preceding frames. The predictor parameters are adapted to the current signal statistics on a frame by frame base, using an LMS based adaptation algorithm. If prediction is activated, the quantizer is fed with a prediction error instead of the original spectral component, resulting in a coding gain.

C.4.2 Encoding Process

For each spectral component up to the limit specified by PRED_SFB_MAX of each channel there is one predictor. The following description is valid for one single predictor and has to be applied to each predictor. As said above, each predictor is identical on both, the encoder and decoder side. Therefore, the predictor structure is the same as shown in Figure 4 and the calculations of the estimate $x_{est}(n)$ of the current spectral component $x(n)$ as well as the calculation and adaptation of the predictor coefficients are exactly the same as those described for the decoder in subclause 8.3.2.

The only difference on the encoder side is that the prediction error has to be calculated according to

$$e(n) = x(n) - x_{est}(n)$$

to be fed to the quantizer. In this case the quantized prediction error is transmitted instead of the quantized spectral component.

C.4.2.1 Predictor Control

In order to guarantee that prediction is only used if this results in a coding gain, an appropriate predictor control is required and a small amount of predictor control information has to be transmitted to the decoder. For the predictor control, the predictors are grouped into scalefactor bands.

The following description is valid for either one single_channel_element() or one channel_pair_element() and has to be applied to each such element. Since prediction is only used if window_sequence is of type ONLY_LONG_SEQUENCE, LONG_START_SEQUENCE or LONG_STOP_SEQUENCE for the channel associated with the single_channel_element() or for both channels associated with the channel_pair_element(), the following applies only in these cases.

The predictor control information for each frame, which has to be transmitted as side information, is determined in two steps. First, it is determined for each scalefactor band whether or not prediction leads to a coding gain and if yes, the **prediction_used** bit for that scalefactor band is set to one. After this has been done for all scalefactor bands up to PRED_SFB_MAX, it is determined whether the overall coding gain by prediction in this frame compensates at least the additional bit need for the predictor side information. If yes, the **predictor_data_present** bit is set to 1, the complete side information including that needed for predictor reset (see below) has to be transmitted and the prediction error value is fed to the quantizer. Otherwise, the **predictor_data_present** bit is set to 0, the **prediction_used** bits are all reset to zero and are not transmitted. In this case, the spectral component value is fed to the quantizer. Figure C.5 shows a block diagram of the prediction unit for one scalefactor band. As described above, the predictor control first operates on all predictors of one scalefactor band and is then followed by a second step over all scalefactor bands.

In case of a `single_channel_element()` or a `channel_pair_element()` with **common_window** = 0 the control information is calculated and valid for the predictor bank(s) of the channel(s) associated with that element. In case of a `channel_pair_element()` with **common_window** = 1 the control information is calculated considering both channels associated with that element together. In this case the control information is valid for both predictor banks of the two channels in common.

C.4.2.2 Reconstruction of the Quantized Spectral Component

Since the reconstructed value of the quantized spectral component is needed as predictor input signal, it has to be calculated in the encoder, see also Figure 8 and Figure C.5. Depending on the value of the **prediction_used** bit, the reconstructed value is either the quantized spectral component or the quantized prediction error. Therefore, the following steps are necessary:

- If the bit is set (1), then the quantized prediction error, reconstructed from data to be transmitted, is added to the estimate $x_{est}(n)$, calculated by the predictor, resulting in the reconstructed value of the quantized spectral component, i.e. $x_{rec}(n) = x_{est}(n) + e_q(n)$
- If the bit is not set (0), then the quantized value of the spectral component is identical to the value reconstructed directly from the data to be transmitted.

C.4.3 Diagrams

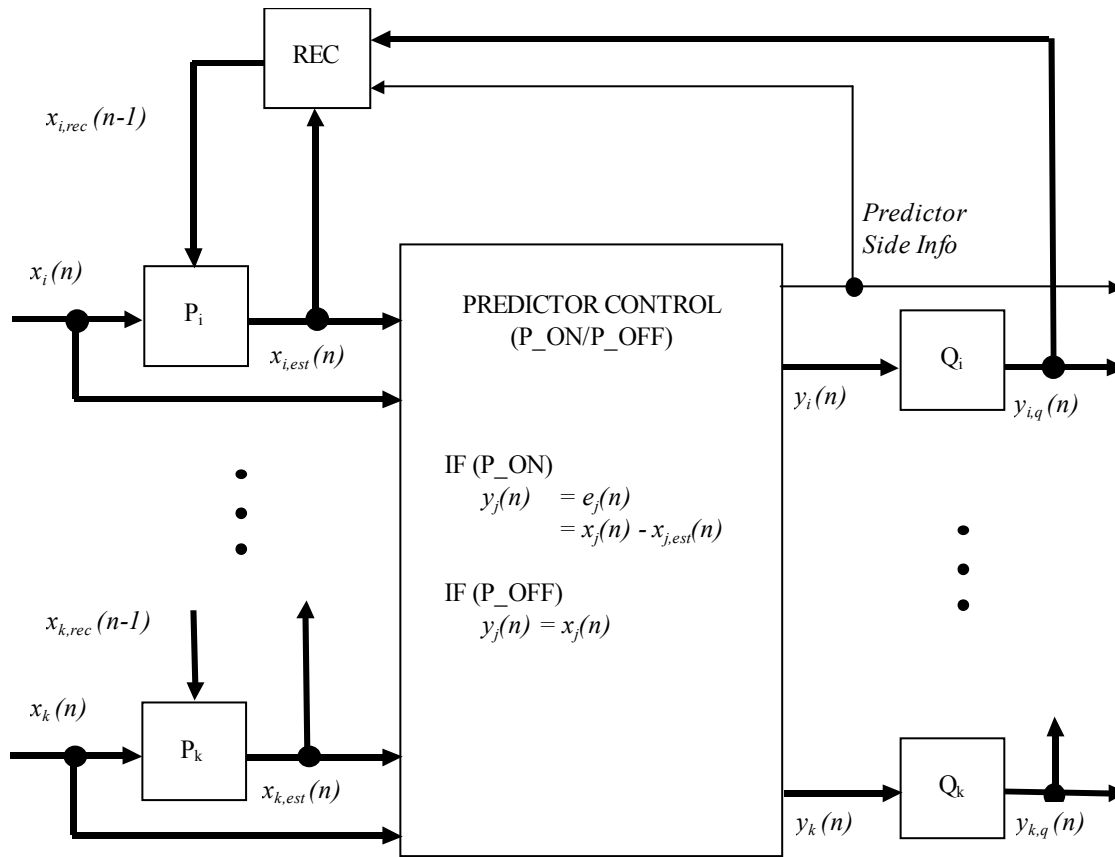

Figure C.5 — Block diagram of prediction unit for one scalefactor band. The complete processing is only shown for predictor P_i (Q - quantizer, REC - reconstruction of last quantized value). Note that the predictor control operates on all predictors $P_i \dots P_j \dots P_k$ of a scalefactor band and is followed by a second control over all scalefactor bands.

C.5 Temporal Noise Shaping (TNS)

Temporal Noise Shaping is used to control the temporal shape of the quantization noise within each window of the transform. This is done by applying a filtering process to parts of the spectral data of each channel.

Encoding is done on a window basis. The following steps are carried out to apply the Temporal Noise Shaping tool to one window of spectral data:

- A target frequency range for the TNS tool is chosen. A suitable choice is to cover a frequency range from 1.5 kHz to the uppermost possible scalefactor band with one filter. Please note that this parameter (TNS_MAX_BANDS) depends on profile and sampling rate as indicated in the normative part.
- Next, a linear predictive coding (LPC) calculation is carried out on the spectral MDCT coefficients corresponding to the chosen target frequency range. For better stability, coefficients corresponding to frequencies below 2.5 kHz may be excluded from this process. Standard LPC procedures as known from speech processing can be used for the LPC calculation, e.g. the well-known Levinson-Durbin algorithm. The calculation is carried out for the maximum permitted order of the noise shaping filter (TNS_MAX_ORDER). Please note that this value depends on the profile as indicated in the normative part.

- As a result of the LPC calculation, the expected prediction gain g_p is known as well as the TNS_MAX_ORDER reflection coefficients $r[]$ (so-called PARCOR coefficients).
- If the prediction gain g_p does not exceed a certain threshold t , no temporal noise shaping is used. In this case, the `tns_data_present` bit is set to zero and TNS processing is finished. A suitable threshold value is $t = 1.4$.
- If the prediction gain g_p exceeds the threshold t , temporal noise shaping is used.
- In a next step the reflection coefficients are quantized using `coef_res` bits. An appropriate choice for `coef_res` is 4 bits. The following pseudo code describes the conversion of the reflection coefficients $r[]$ to index values `index[]` and back to quantized reflection coefficients `rq[]`.

```

iqfac = ((1 << (coef_res-1)) - 0.5) / (pi/2.0);
iqfac_m = ((1 << (coef_res-1)) + 0.5) / (pi/2.0);

/* Reflection coefficient quantization */
for (i = 0; i < TNS_MAX_ORDER; i++) {
    index[i] = NINT( arcsin( r[i] ) * ((r[i] >= 0) ? iqfac : iqfac_m) );
}
/* Inverse quantization */
for (i = 0; i < TNS_MAX_ORDER; i++) {
    rq[i] = sin( index[i] / ((index[i] >= 0) ? iqfac : iqfac_m) );
}

```

where `arcsin()` denotes the inverse `sin()` function.

- The order of the used noise shaping filter is determined by subsequently removing all reflection coefficients with an absolute value smaller than a threshold p from the "tail" of the reflection coefficient array. The number of the remaining reflection coefficients is the order of the noise shaping filter. A suitable threshold for truncation is $p = 0.1$.
- The remaining reflection coefficients `rq[]` are converted into order+1 linear prediction coefficients `a[]` (known as "step-up procedure"). A description of this procedure is provided in the normative part as a part of the tool description (see `/* Conversion to LPC coefficients */`).
- The computed LPC coefficients `a[]` are used as the encoder noise shaping filter coefficients. This FIR filter is slid across the specified target frequency range exactly the way it is described in the normative part for the decoding process (tool description). The difference between the decoding and encoding filtering is that the all-pole (auto-regressive) filter used for decoding is replaced by its inverse all-zero (moving-average) filter, i.e. replacing the decoder filter equation

$$y[n] = x[n] - a[1]*y[n-1] - \dots - a[order]*y[n-order]$$

by the inverse (encoder) filter equation

$$y[n] = x[n] + a[1]*x[n-1] + \dots + a[order]*x[n-order]$$

By default, an upward direction of the filtering is appropriate.

- Finally, the side information for Temporal Noise Shaping is transmitted:

Table C.25 — TNS side information

Data Element	Algorithmic Variable or Value
<code>n_filt</code>	1
<code>coef_res</code>	<code>coef_res-3</code>
<code>coef_compress</code>	0
<code>length</code>	Number of processed scalefactor bands
<code>direction</code>	0 (upwards)
<code>order</code>	Order of noise shaping filter
<code>coef[]</code>	<code>index[]</code>

Optionally, the use of the `coef_compress` field allows saving 1 bit per transmitted reflection coefficient if none of the reflection coefficients use more than half of their full range. Specifically, if the two most significant bits of each quantized reflection coefficient are either '00' or '11', `coef_compress` may be set to a value of one and the size of the transmitted quantized reflection coefficients decreased by one.

C.6 Joint Coding

C.6.1 M/S Stereo

The decision to code left and right coefficients as either left + right (L/R) or mid/side (M/S) is made on a noiseless coding band by noiseless coding band basis for all spectral coefficients in the current block. For each noiseless coding band the following decision process is used:

1. For each noiseless coding band, not only L and R raw thresholds, but also $M = (L+R)/2$ and $S = (L-R)/2$ raw thresholds are calculated. For the raw M and S thresholds, rather than using the tonality for the M or S threshold, one uses the more tonal value from the L or R calculation in each threshold calculation band, and proceed with the psychoacoustic model for M and S from the M and S energies and the minimum of the L or R values for $C(\omega)$ in each threshold calculation band. The values that are provided to the imaging control process are identified in the psychoacoustic model information section as $en(b)$ (the spread normalized energy) and $nb(b)$, the raw threshold.
2. The raw thresholds for M, S, L and R, and the spread energy for M, S, L and R, are all brought into an "imaging control process". The resulting adjusted thresholds are inserted as the values for $cb(b)$ into step 11 of the psychoacoustic model for further processing.
3. The final, protected and adapted to coder-band thresholds for all of M,S,L and R are directly applied to the appropriate spectrum by quantizing the actual L, R, M and S spectral values with the appropriate calculated and quantized threshold.
4. The number of bits actually required to code M/S, and the number of bits required to code L/R are calculated.
5. The method that uses the least bits is used in each given noiseless coding band, and the stereo mask is set accordingly.

With these definitions

$M_{thr}, S_{thr}, R_{thr}, L_{thr}$ raw thresholds. (the $nb(b)$ from step 10 of the psychoacoustic model)

$M_{engy}, S_{engy}, R_{engy}, L_{engy}$ spread energy. ($en(b)$ from step 6 of the psychoacoustic model)

$M_{fthr}, S_{fthr}, R_{fthr}, L_{fthr}$ final (output) thresholds. (returned as $nb(b)$ in step 11 of the psychoacoustic model)

$b_{max}(b)$ BMLD protection ratio, as can be calculated from

$$b_{max}(b) = 10^{-3} \cdot \left[0.5 + 0.5 \cdot \cos \left(\pi \cdot \frac{\min(b_{val}(b), 15.5)}{15.5} \right) \right]$$

the imaging control process for each noiseless coding band is as follows:

$$t = M_{thr}/S_{thr}$$

if ($t > 1$)

$$t = 1/t$$

$$R_{fthr} = \max(R_{thr} \cdot t, \min(R_{thr}, b_{max} \cdot R_{engy}))$$

$$Lfthr = \max(Lthr \cdot t, \min(Lthr, bmax) \cdot Lengy)$$

$$t = \min(Lthr, Rthr)$$

$$Mfthr = \min(t, \max(Mthr, \min(Sengy \cdot bmax, Sthr)))$$

$$Sfthr = \min(t, \max(Sthr, \min(Mengy \cdot bmax, Mthr)))$$

C.6.2 Intensity Stereo Coding

Intensity stereo coding is used to exploit irrelevance in the between both channels of a channel pair in the high frequency region. The following procedure describes one possible implementation while several different implementations are possible within the framework of the defined bitstream syntax.

Encoding is done on a window group basis. The following steps are carried out to apply the intensity stereo coding tool to one window group of spectral data:

- A suitable approach is to code a consecutive region of scalefactor bands in intensity stereo technique starting above a lower border frequency f_0 . An average value of $f_0 = 6$ kHz is appropriate for most types of signals.
- For each scalefactor band, the energy of the left, right and the sum channel is calculated by summing the squared spectral coefficients, resulting in values $E_l[sfb]$, $E_r[sfb]$, $E_s[sfb]$. If the window group comprises several windows, the energies of the included windows are added.
- For each scalefactor band, the corresponding intensity position value is computed as

$$is_position[sfb] = NINT \left(2 \cdot \log_2 \left(\frac{E_l[sfb]}{E_r[sfb]} \right) \right)$$

- Next, the intensity signal spectral coefficients $spec_i[i]$ are calculated for each scalefactor bands by adding spectral samples from the left and right channel ($spec_l[i]$ and $spec_r[i]$) and rescaling the resulting values like

$$spec_i[i] = (spec_l[i] + spec_r[i]) \cdot \sqrt{\frac{E_l[sfb]}{E_s[sfb]}}$$

- The intensity signal spectral components are used to replace the corresponding left channel spectral coefficients. The corresponding spectral coefficients of the right channel are set to zero.

Then, the standard process for quantization and encoding is performed on the spectral data of both channels. However, the prediction status of the right channel predictors is forced to "off" for the scalefactor bands coded in intensity stereo. These predictors are updated by using an intensity decoded version of the quantized spectral coefficients. The procedure for this is described in the tool description for the intensity stereo decoding process in the normative part.

Finally, before transmission the Huffman codebook INTENSITY_HCB (15) is set in the sectioning information for all scalefactor bands that are coded in intensity stereo.

C.7 Quantization

C.7.1 Introduction

The description of the AAC quantization module is subdivided into three levels. The top level is called "loops frame program". The loops frame program calls a subroutine named "outer iteration loop" which calls the subroutine "inner iteration loop". For each level a corresponding flow diagram is shown.

The loops module quantizes an input vector of spectral data in an iterative process according to several demands. The inner loop quantizes the input vector and increases the quantizer step size until the output vector can be coded with the available number of bits. After completion of the inner loop an outer loop checks the distortion of each scalefactor band and, if the allowed distortion is exceeded, attenuates the scalefactor band and calls the inner loop again.

AAC loops module input:

1. vector of the magnitudes of the spectral values `mdct_line(0..1023)`.
2. `xmin(sb)` (see subclause C.1.4, step 0)
3. `mean_bits` (average number of bits available for encoding the bitstream).
4. `more_bits`, the number of bits in addition to the average number of bits, calculated by the psychoacoustic module out of the perceptual entropy (PE).
5. the number and width of the scalefactor bands (see Table 45 to Table 57)
6. for short block grouping the spectral values have to be interleaved so that spectral lines that belong to the same scalefactor band but to different block types which shall be quantized with the same scalefactors are put together in one (bigger) scalefactor band (for a full description of grouping see subclause 8.3.4)

AAC loops module output:

1. vector of quantized values `x_quant(0..1023)`.
2. a scalefactor for each scalefactor band (`sb`)
3. `common_scalefac` (quantizer step size information for all scalefactor bands)
4. number of unused bits available for later use.

C.7.2 Preparatory Steps

C.7.2.1 Reset of all Iteration Variables

1. The start value of `common_scalefac` for the quantizer is calculated so that all quantized MDCT values can be encoded in the bitstream :

$$\text{start_common_scalefac} = \text{ceiling}(16/3 * (\log_2((\text{max_mdct_line} \wedge (3/4)) / \text{MAX_QUANT})))$$

`max_mdct_line` is the largest absolute MDCT coefficient and `ceiling()` is the function which rounds to the nearest integer in the direction of positive infinity. `MAX_QUANT` is the maximum quantized value which can be encoded in the bitstream, defined as 8191. During the iteration process, the `common_scalefac` must not become less than `start_common_scalefac`.

2. `Scalefactor[sb]` is set to zero for all values of `sb`.

C.7.3 Bit Reservoir Control

Bits are saved to the reservoir when fewer than the `mean_bits` are used to code one frame.

$$\text{mean_bits} = \text{bit_rate} * 1024 / \text{sampling_rate}.$$

The number of bits which can be saved in the bit reservoir at maximum is called 'max_bit_reservoir' which is calculated using the procedure outlined in subclause 8.2.3. If the reservoir is full, unused bits have to be encoded in the bitstream as fillbits.

The maximum amount of bits available for a frame is the sum of mean_bits and bits saved in the bit reservoir.

The number of bits that should be used for encoding a frame depends on the more_bits value which is calculated by the psychoacoustic model and the maximum available bits. The simplest way to control bit reservoir is :

```
if more_bits > 0 :
    available_bits = mean_bits + min ( more_bits, bit_reservoir_state[frame] )
if more_bits < 0 :
    available_bits = mean_bits + max ( more_bits, bit_reservoir_state[frame]
    - max_bit_reservoir )
```

C.7.4 Quantization of MDCT Coefficients

The formula for the quantization in the encoder is the inverse of the decoder dequantization formula (see also the decoder description) :

$$x_{\text{quant}} = \text{int} \left(\left(\text{abs}(\text{mdct_line}) * (2^{(-1/4 * (\text{sf_decoder} - \text{SF_OFFSET}))}) \right)^{3/4} + \text{MAGIC_NUMBER} \right)$$

MAGIC_NUMBER is defined to 0.4054, SF_OFFSET is defined as 100 and mdct_line is one of spectral values, which is calculated from the MDCT. These values are also called 'coefficients'. The scalefactor 'sf_decoder' is the same as 'sf[g][sfb]' defined in clause 11.

For use in the iteration loops, the scalefactor 'sf_decoder' is split in two variables:

$$\text{sf_decoder} = \text{common_scalefac} - \text{scalefactor} + \text{SF_OFFSET}$$

It follows from this, that the formula used in the distortion control loop is:

$$x_{\text{quant}} = \text{int} \left(\left(\text{abs}(\text{mdct_line}) * (2^{(-1/4 * (\text{scalefactor} - \text{common_scalefac}))}) \right)^{3/4} + \text{MAGIC_NUMBER} \right)$$

The signs of scalefactor is such that a *positive* change *increases* the magnitude of x_{quant} , and so *decreases* the distortion and *increases* the number of bits used.

The sign of the *mdct_line* is saved separately and added again only for counting the bits and encoding the bitstream.

C.7.4.1 Outer Iteration Loop (Distortion Control Loop)

The outer iteration loop controls the quantization noise which is produced by the quantization of the frequency domain lines within the inner iteration loop. The coloring of the noise is done by multiplication of the lines within scalefactor bands with the actual scalefactors before doing the quantization. The following pseudo-code illustrates the multiplication.

do for each scalefactor band sb:

do from lower index to upper index i of scalefactor band

$$\text{mdct_scaled}(i) = \text{abs}(\text{mdct_line}(i))^{3/4} * 2^{(3/16 * \text{scalefactor}(sb))}$$

end do

end do

C.7.4.2 Call of Inner Iteration Loop

For each outer iteration loop (distortion control loop) the inner iteration loop (rate control loop) is called. The parameters are the frequency domain values with the scalefactors applied to the values within the scalefactor bands ($mdct_scaled(0..1023)$), a start value for $common_scalefac$, and the number of bits which are available to the rate control loop. The result is the number of bits actually used and the quantized frequency lines $x_quant(i)$, and a new $common_scalefac$.

The formula to calculate the quantized MDCT coefficients is:

$$x_quant(i) = int ((mdct_scaled (i) * 2^{(-3/16 * common_scalefac)} + MAGIC_NUMBER)$$

The bits, that would be needed to encode the quantized values and the side information (scalefactors etc.) are counted according to the bitstream syntax, described in clause 9.

C.7.4.3 Attenuation of Scalefactor Bands which Violate the Masking Threshold

The calculation of the distortion ($error_energy(sb)$) of the scalefactor band is done as follows:

```
do for each scalefactor band sb:
  error_energy(sb)=0
  do from lower index to upper index i of scalefactor band
    error_energy(sb) = error_energy(sb) + (abs( mdct_line(i))
      - (x_quant(i) ^ (4/3) * 2^(¼ * (scalefactor(sb) - common_scalefac
)))) ^2
  end do
end do
```

All spectral values of the scalefactor bands which have a distortion that exceeds the allowed distortion ($xmin(sb)$) are attenuated according to formula in subclause C.7.4.1, the new scalefactors can be calculated according to this pseudocode:

```
do for each scalefactor band sb
  if ( error_energy(sb) > xmin(sb) ) then
    scalefactor(sb) = scalefactor(sb) - 1
  end if
end do
```

C.7.4.4 Conditions for the Termination of the Loops Processing

Normally the loops processing terminates, if there is no scalefactor band with more than the allowed distortion. However this is not always possible to obtain. In this case there are other conditions to terminate the outer loop. If

- All scalefactor bands with an energy exceeding $xmin(sb)$ are already attenuated, or
- The difference between two consecutive scalefactors is greater than 60

The loop processing stops, and by restoring the saved scalefactors(sb) a useful output is available. For real-time implementation, there might be a third condition added which terminates the loops in case of a lack of computing time.

The procedure described above is only valid in the case the number of available bits is equal to the number of required bits corresponding to the perceptual entropy. In the case the number of available bits is higher or lower than the number of required bits, it is the objective of the loops module to create a constant ratio between the quantisation noise and the masked threshold over all scale factor bands (constant Noise to Mask Ratio (NMR)). This can be realised by applying an offset to the target allowed distortion $xmin(sb)$, that is the same for all scale factor bands, prior to starting the loops module.

C.7.4.5 Inner Iteration Loop (Rate Control Loop)

The inner iteration loop calculates the actual quantization of the frequency domain data (*mdct_scaled*) with the following function, which uses the formula from subclause C.7.4.2:

```
quantize_spectrum(x_quant[] , mdct_scaled[] , common_scalefac):
  do for all MDCT coefficients i :
    x_quant(i) = int ((mdct_scaled (i) * 2^(-3/16 * common_scalefac))
                     + MAGIC_NUMBER)
  end do
```

and then calls a function *bit_count()*. This function counts the number of bits that would be necessary to encode a bitstream frame according to clause 6.

The inner iteration loop can be implemented using successive approximation:

```
inner_loop():
  if (outer_loop_count == 0)
    common_scalefac = start_common_scalefac;
    quantizer_change = 32;
  else
    quantizer_change = 1;
  end if
  do
    quantize_spectrum();
    counted_bits = bit_count();
    if (counted_bits > available_bits) then
      common_scalefac = common_scalefac + quantizer_change;
    else
      common_scalefac = common_scalefac - quantizer_change;
    end if
    quantizer_change = int (quantizer_change / 2) ;
    if (quantizer_change == 0) && (counted_bits > available_bits)
      quantizer_change = 1;
    end if
  while (quantizer_change != 0)
```

Due to the choice of *start_common_scalefac* calculated from subclause C.7.2.1, after the first run through the inner loop the number of needed bits is usually greater than the available bits , and therefore *common_scalefac* will be increased by the *quantizer_change*.

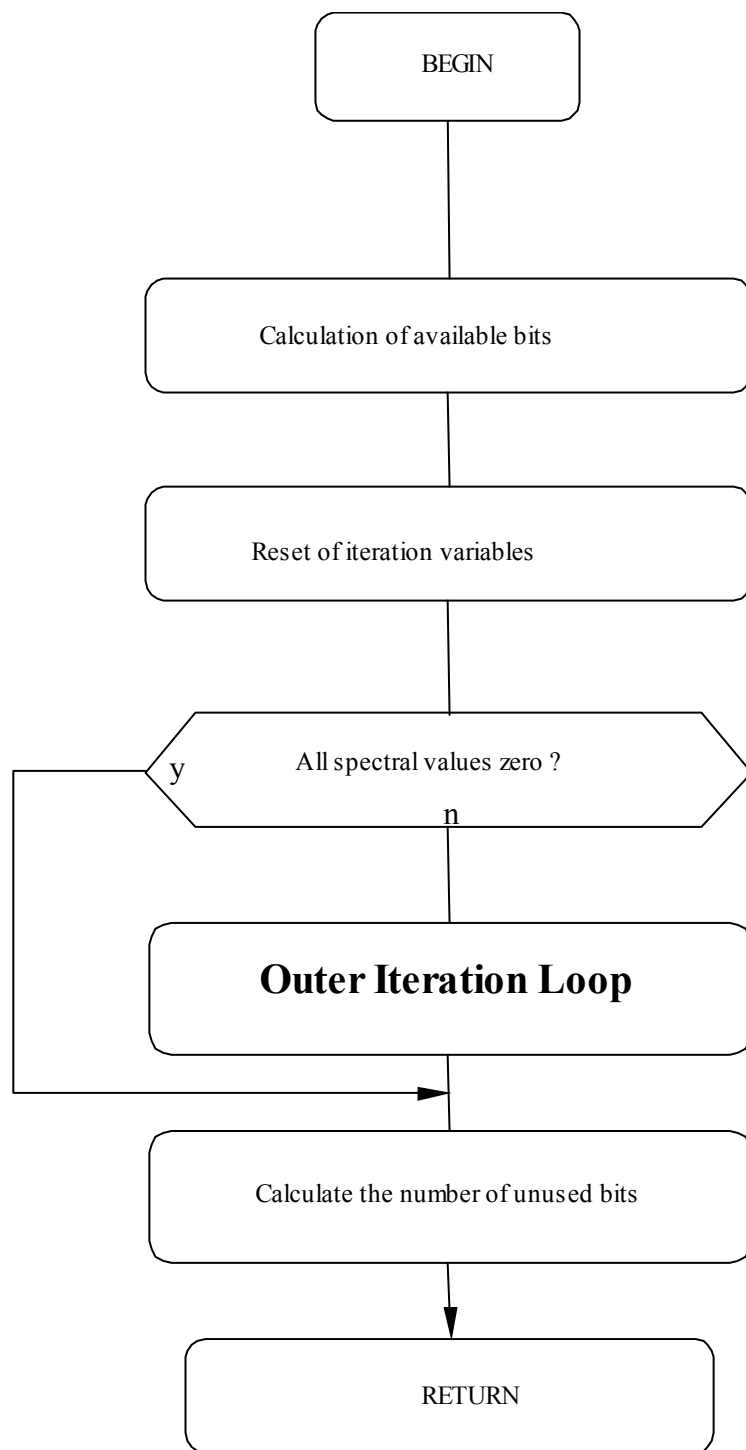

Figure C.6 — AAC iteration loop

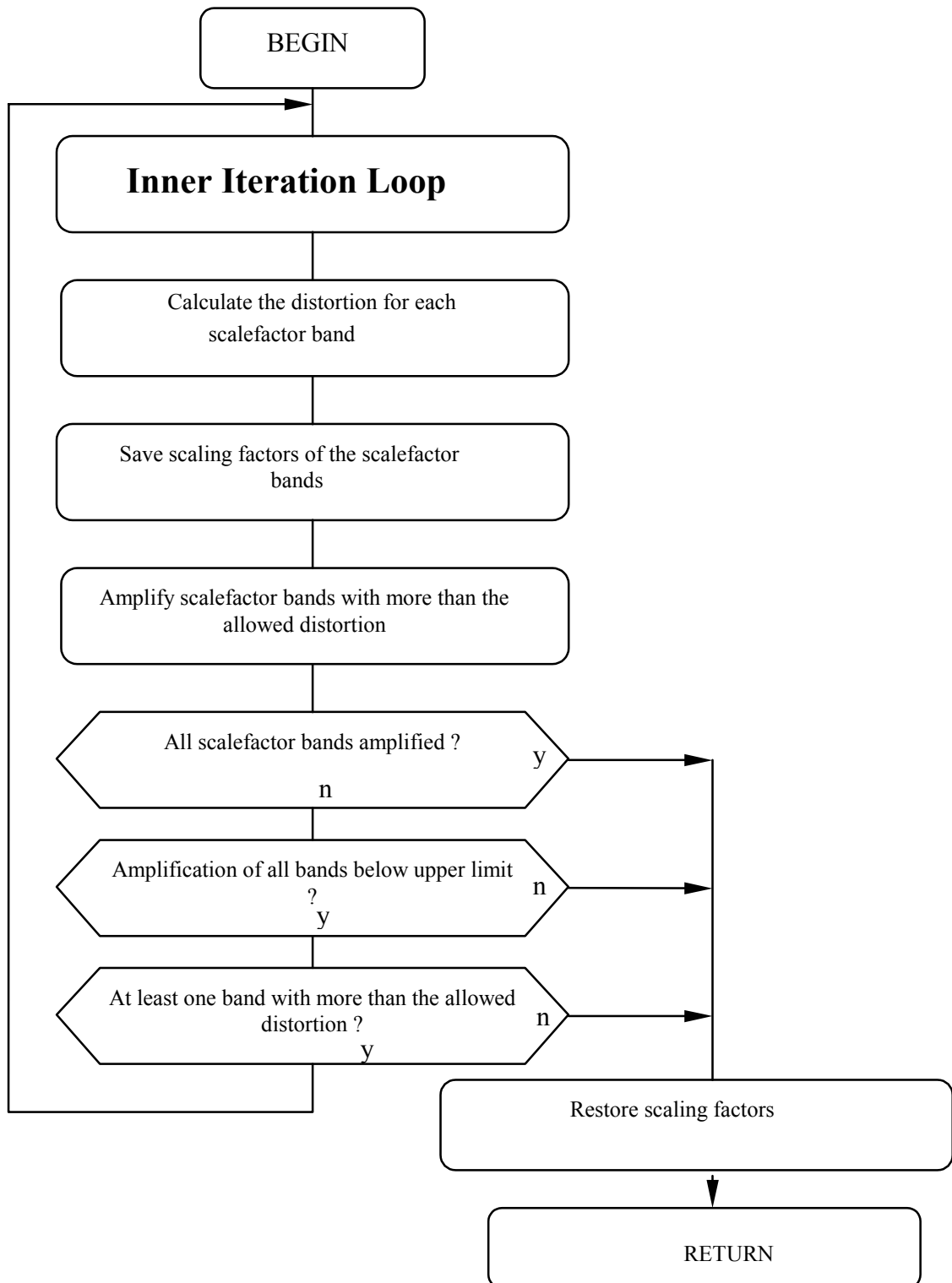

Figure C.7 — AAC outer iteration loop

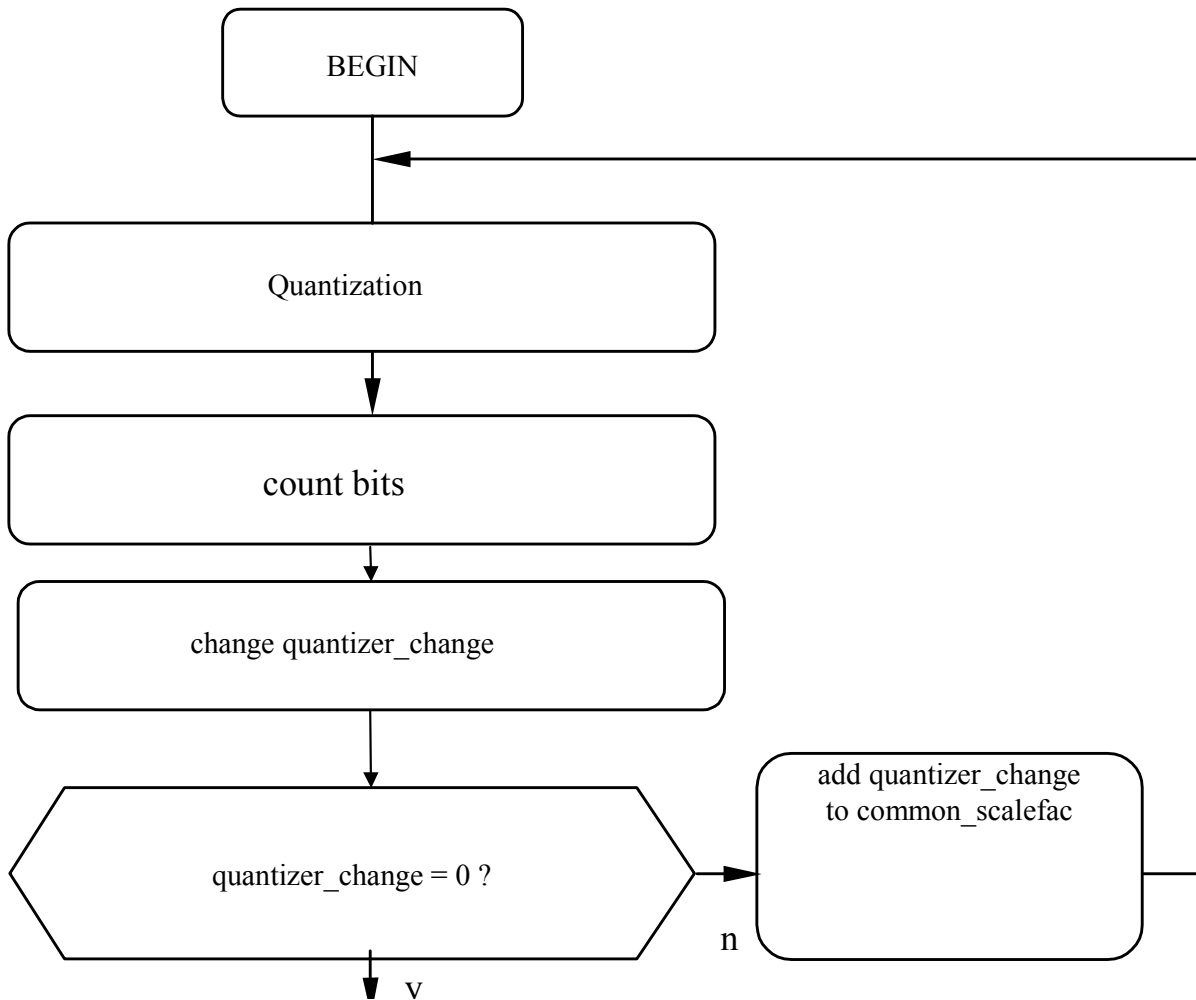

Figure C.8 — AAC inner iteration loop

C.8 Noiseless Coding

C.8.1 Introduction

In the AAC encoder the input to the noiseless coding module is the set of 1024 quantized spectral coefficients. Since the noiseless coding is done inside the quantizer inner loop, it is part of an iterative process that converges when the total bit count (of which the noiseless coding is the vast majority) is within some interval surrounding the allocated bit count. This section will describe the encoding process for a single call to the noiseless coding module.

Noiseless coding is done via the following steps:

- Spectrum clipping
- Preliminary Huffman coding using maximum number of sections
- Section merging to achieve lowest bit count

C.8.2 Spectrum Clipping

As a first step a method of noiseless dynamic range limiting may be applied to the spectrum. Up to four coefficients can be coded separately as magnitudes in excess of one, with a value of +1 left in the quantized coefficient array to carry the sign. The index of the scalefactor band containing the lowest-frequency “clipped”

coefficients is sent in the bitstream. Each of the “clipped” coefficients is coded as a magnitude (in excess of 1) and an offset from the base of the previously indicated scalefactor band. For this the long block scalefactor bands and coefficient ordering within those bands are used regardless of the window sequence. One strategy for applying spectrum clipping is to clip high-frequency coefficients whose absolute amplitudes are larger than one. Since the side information for carrying the clipped coefficients costs some bits, this noiseless compression is applied only if it results in a net savings of bits.

C.8.3 Sectioning

The noiseless coding segments the set of 1024 quantized spectral coefficients into *sections*, such that a single Huffman codebook is used to code each section (the method of Huffman coding is explained in a later section). For reasons of coding efficiency, section boundaries can only be at scalefactor band boundaries so that for each section of the spectrum one must transmit the length of the section, in scalefactor bands, and the Huffman codebook number used for the section.

Sectioning is dynamic and typically varies from block to block, such that the number of bits needed to represent the full set of quantized spectral coefficients is minimized. This is done using a greedy merge algorithm starting with the maximum possible number of sections each of which uses the Huffman codebook with the smallest possible index. Sections are merged if the resulting merged section results in a lower total bit count, with merges that yield the greatest bit count reduction done first. If the sections to be merged do not use the same Huffman codebook then the codebook with the higher index must be used.

Sections often contain only coefficients whose value is zero. For example, if the audio input is band limited to 20 kHz or lower, then the highest coefficients are zero. Such sections are coded with Huffman codebook zero, which is an escape mechanism that indicates that all coefficients are zero and it does not require that any Huffman codewords be sent for that section.

C.8.4 Grouping and Interleaving

If the window sequence is eight short windows then the set of 1024 coefficients is actually a matrix of 8 by 128 frequency coefficients representing the time-frequency evolution of the signal over the duration of the eight short windows. Although the sectioning mechanism is flexible enough to efficiently represent the 8 zero sections, *grouping* and *interleaving* provide for greater coding efficiency. As explained earlier, the coefficients associated with contiguous short windows can be grouped such that they share scalefactors amongst all scalefactor bands within the group. In addition, the coefficients within a group are interleaved by interchanging the order of scalefactor bands and windows. To be specific, assume that before interleaving the set of 1024 coefficients c are indexed as

$$c[g][w][b][k]$$

where

g is the index on groups

w is the index on windows within a group

b is the index on scalefactor bands within a window

k is the index on coefficients within a scalefactor band

and the right-most index varies most rapidly.

After interleaving the coefficients are indexed as

$$c[g][b][w][k]$$

This has the advantage of combining all zero sections due to band-limiting within each group.

C.8.5 Scalefactors

The coded spectrum uses one quantizer per scalefactor band. The step sizes of each of these quantizers is specified as a set of scalefactors and a global gain which normalizes these scalefactors. In order to increase compression, scalefactors associated with scalefactor bands that have only zero-valued coefficients are ignored in the coding process and therefore do not have to be transmitted. Both the global gain and scalefactors are quantized in 1.5 dB steps. The global gain is coded as an 8-bit unsigned integer and the scalefactors are differentially encoded relative to the previous scalefactor (or global gain for the first scalefactor) and then Huffman coded. The dynamic range of the global gain is sufficient to represent full-scale values from a 24-bit PCM audio source.

C.8.6 Huffman Coding

Huffman coding is used to represent n-tuples of quantized coefficients, with the Huffman code drawn from one of 11 codebooks. The spectral coefficients within n-tuples are ordered (low to high) and the n-tuple size is two or four coefficients. The maximum absolute value of the quantized coefficients that can be represented by each Huffman codebook and the number of coefficients in each n-tuple for each codebook is shown in Table C.26. There are two codebooks for each maximum absolute value, with each representing a distinct probability distribution function. The best fit is always chosen. In order to save on codebook storage (an important consideration in a mass-produced decoder), most codebooks represent unsigned values. For these codebooks the magnitude of the coefficients is Huffman coded and the sign bit of each non-zero coefficient is appended to the codeword.

Table C.26 — Huffman Codebooks

Codebook index	n-Tuple size	Maximum absolute value	Signed values
0		0	
1	4	1	yes
2	4	1	yes
3	4	2	no
4	4	2	no
5	2	4	yes
6	2	4	yes
7	2	7	no
8	2	7	no
9	2	12	no
10	2	12	no
11	2	16 (ESC)	no

Two codebooks require special note: codebook 0 and codebook 11. As mentioned previously, codebook 0 indicates that all coefficients within a section are zero. Codebook 11 can represent quantized coefficients that have an absolute value greater than or equal to 16. If the magnitude of one or both coefficients is greater than or equal to 16, a special *escape coding* mechanism is used to represent those values. The magnitude of the coefficients is limited to no greater than 16 and the corresponding 2-tuple is Huffman coded. The sign bits, as needed, are appended to the codeword. For each coefficient magnitude greater or equal to 16, an *escape sequence* is also appended, as follows:

escape sequence = <escape_prefix><escape_separator><escape_word>

where

<escape_prefix> is a sequence of N binary “1’s”

<escape_separator> is a binary “0”

<escape_word> is an N+4 bit unsigned integer, msb first

and N is a count that is just large enough so that the magnitude of the quantized coefficient is equal to $2^{(N+4)} + \text{<escape_word>}$

C.9 Features of AAC dynamic range control

In order to handle source material with variable peak levels, mean levels and dynamic range in a manner that minimizes the variability for the consumer, it is necessary to control the reproduced level such that, for instance, dialogue level or mean music level is set to a consumer controlled level at reproduction, regardless of how the programme was originated. Additionally, not all consumers will be able to audition the programmes in a good (i.e. low noise) environment, with no constraint on how loud they make the sound. The car environment, for instance, has a high ambient noise level and it can therefore be expected that the listener will want to reduce the range of levels that would otherwise be reproduced.

For both of these reasons, dynamic range control has to be available within the specification of AAC. To achieve this, it is necessary to accompany the bit-rate reduced audio with data used to set and control the dynamic range of the programme items. This control has to be specified relative to a reference level and in relationship to the important programme elements, e.g. the dialogue.

The features of the dynamic range control are as follows:

1. Dynamic Range Control is entirely optional. Therefore, with correct syntax, there is no change in complexity for those not wishing to invoke DRC.
2. The bit-rate reduced audio data is transmitted with the full dynamic range of the source material, with supporting data to assist in dynamic range control.
3. The dynamic range control data can be sent every frame to reduce to a minimum the latency in setting replay gains.
4. The dynamic range control data is sent using the 'fill_element' feature of AAC.
5. The *Reference Level* is defined as Full-scale.
6. The *Programme Reference Level* is transmitted to permit level parity between the replay levels of different sources and to provide a reference about which the dynamic range control may be applied. It is that feature of the source signal that is most relevant to the subjective impression of the loudness of a programme, such as the level of the dialogue content of a programme or the average level of a music programme.
7. The *Programme Reference Level* represents that level of programme that may be reproduced at a set level relative to the *Reference Level* in the consumer hardware to achieve replay level parity. Relative to this, the quieter portions of the programme may be increased in level and the louder portions of the programme may be reduced in level.
8. *Programme Reference Level* is specified within the range 0 to -31.75 dB relative to *Reference Level*.
9. *Programme Reference Level* uses a 7 bit field with 0.25 dB steps.
10. The dynamic range control is specified within the range ± 31.75 dB.
11. The dynamic range control uses an 8 bit field (1 sign, 7 magnitude) with 0.25 dB steps.
12. The dynamic range control can be applied to all of an audio channel's spectral coefficients frequency bands as a single entity or the coefficients can be split into with different scale factor bands, each being controlled separately by separate sets of dynamic range control data.

13. The dynamic range control can be applied to all channels (of a stereo or multichannel bitstream) as a single entity or can be split, with sets of channelsChannels being controlled separately by separate sets of dynamic range control data.
14. If an expected set of dynamic range control data is missing, the last received valid values should be used.
15. Not all elements of the dynamic range control data are sent every time. For instance, *Programme Reference Level* may only be sent on average once every 200 ms.
16. Where necessary, error detection/protection is provided by the Transport Layer.
17. The user shall be given the means to alter the amount of dynamic range control, present in the bitstream, that is applied to the level of the signal.

Annex D (informative)

Patent Holders

D.1 List of Patent Holders

The International Organization for Standardization and the International Electrotechnical Commission (IEC) draw attention to the fact that it is claimed that compliance with this part of ISO/IEC 13818 may involve the use of patents.

ISO and IEC take no position concerning the evidence, validity and scope of these patent rights.

The holders of these patent rights have assured the ISO and IEC that they are willing to negotiate licences under reasonable and non-discriminatory terms and conditions with applicants throughout the world. In this respect, the statements of the holders of these patents right are registered with ISO and IEC. Information may be obtained from the companies listed in Table D.1.

Attention is drawn to the possibility that some of the elements of this part of ISO/IEC 13818 may be the subject of patent rights other than those identified in this annex. ISO and IEC shall not be held responsible for identifying any or all such patent rights.

Table D.1 — Companies who supplied patent statements

AT&T
BOSCH
Dolby Laboratories, Inc.
Fraunhofer Gesellschaft
GCL
Lucent Technologies
NEC Corporation
Philips Electronics N.V.
Sony Corporation
Thomson Multimedia

Annex E (informative)

Registration Procedure

E.1 Procedure for the Request of a Registered Identifier (RID)

Requesters of a RID shall apply to the Registration Authority. Registration forms shall be available from the Registration Authority. Information which the requester shall provide is given in subclause E.3. Companies and organizations are eligible to apply.

E.2 Responsibilities of the Registration Authority

The primary responsibilities of the Registration Authority administrating the registration of copyright_identifiers is outlined in this clause ; certain other responsibilities may be found in the JTC 1 Directives. The Registration Authority shall :

- a) implement a registration procedure for application for a unique RID in accordance with Annex H of the JTC 1 Directives ;
- b) receive and process the applications for allocation of the work type code identifier from Copyright Registration Authority ;
- c) ascertain which applications received are in accordance with this registration procedure, and to inform the requester within 30 days of receipt of the application of their assigned RID ;
- d) inform application providers whose request is denied in writing within 30 days of receipt of the application, and also inform the requesting party of the appeals process ;
- e) maintain an accurate register of the allocated RID. Revisions to the contact information and technical specifications shall be accepted and maintained by the Registration Authority ;
- f) make the contents of this register available upon request to any interested party ;
- g) maintain a data base of RID request forms, granted and denied. Parties seeking technical information on the format of private data which has a copyright_identifier shall have access to such information which is part of the data base maintained by the Registration Authority ;
- h) report its activities to JTC 1, the ITTF, and the JTC 1/SC 29 Secretariat, or their respective assignees, annually on a schedule mutually agreed upon.

E.3 Contact Information of the Registration Authority

Organization Name:

Address:

Telephone:

Fax:

E.4 Responsibilities of Parties Requesting a RID

The party requesting a RID for the purpose of copyright identification shall :

- a) apply using the Form and procedures supplied by the Registration Authority ;
- b) provide contact information describing how a complete description of the copyright organization can be obtained on a non-discriminatory basis;
- c) include technical details of the syntax and semantics of the data format used to describe the audio-visual works or other copyrighted works within the additional_copyright_info field. Once registered, the syntax used for the additional copyright information shall not change;
- d) agree to institute the intended use of the granted copyright_identifier within a reasonable time frame;
- e) to maintain a permanent record of the application form and the notification received from the Registration Authority of each granted copyright_identifier.

E.5 Appeal procedure for Denied Applications

The Registration Management Group is formed to have jurisdiction over appeals relating to a denied request for a RID. The RMG shall have a membership who are nominated by P and L members of the ISO technical body responsible for this part of ISO/IEC 13818. It shall have a convenor and secretariat nominated from its members. The Registration Authority is entitled to nominate one non-voting observing member.

The responsibilities of the RMG shall be :

- a) To review and act on all appeals within a reasonable time frame ;
- b) to inform, in writing, organisations which make an appeal for reconsideration of its petition of the RMGs disposition of the matter;
- c) to review the annual report of the Registration Authority summary of activities;
- d) to supply ISO member bodies with information concerning the scope of operation of the Registration Authority.

Annex F
(informative)

Registration Application Form

Contact information of organization requesting a Registered Identifier (RID)

Organization Name :

Address :

Telephone :

Fax :

E-mail :

Statement of an intention to apply the assigned RID

RID application domain : using guidelines to be provided by the Registration Authority

Date of intended implementation of the RID

Authorized representative

Name :

Title :

Address :

Signature _____

For official use only of the Registration Authority

Registration Rejected _____

Registration Granted _____ Registration Value _____

Attachment 1: Attachment of technical details of the registered data format

Attachment 2: Attachment of notification of appeal procedure for rejected applications

Annex G (informative)

Registration Authority

**Registration Authority
Diagramm of administration structure**

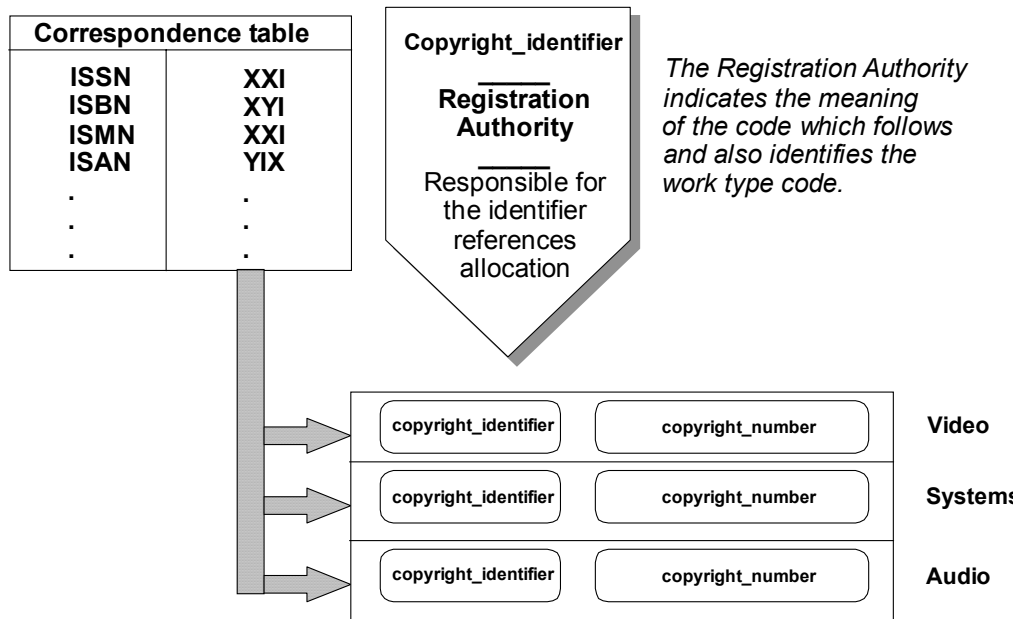

Examples



All the copyright_identifiers are registered by the Registration Authority, uniquely for copyright_numbers standardized by ISO. Each organization which allocates copyright_numbers requests a specific copyright_identifier from the Registration Authority. e.g. Staatsbibliothek Preussischer Kulturbesitz, designated by ISO to manage I.S.B.N., asks for a specific copyright_identifier from the R.A. for book numbering.

Bibliography

- [1] M. Bosi, K. Brandenburg, S. Quackenbush, L. Fielder, K. Akagiri, H. Fuchs, M. Dietz, J. Herre, G. Davidson, Y. Oikawa, "ISO/IEC MPEG-2 Advanced Audio Coding", Journal of the Audio Engineering Society, Vol. 45, no. 10, pp. 789-814, October 1997.
- [2] ITU-R Document TG10-2/3- E only, *Basic Audio Quality Requirements for Digital Audio Bit-Rate Reduction Systems for Broadcast Emission and Primary Distribution*, 28 October 1991.
- [3] F. J. Harris, On the Use of Windows For Harmonic Analysis of the Discrete Fourier Transform, Proc. of the IEEE, Vol. 66, pp. 51- 83, January 1975.

